



Reyrolle  
Protection  
Devices

## 7PG21 – Solkor R/Rf

Pilot Wire Current Differential Protection

Answers for energy

**SIEMENS**

# 7PG21 – Solkor R/Rf

Pilot Wire Current Differential Protection

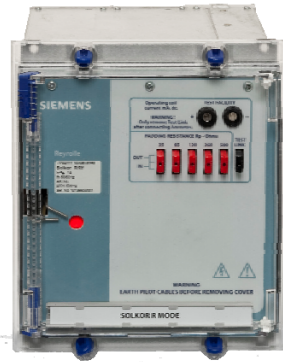

## Description

Solkor R & Solkor Rf are well established pilot wire feeder differential protections operating on the current balance principle. The R/Rf relay is primarily intended for use in the Rf mode which has the advantage of increased operating speed but can be simply changed to R mode for compatibility with pre-installed remote end relays which are older 5kV Solkor R type relays.

The relay is suitable for application on a single pair of privately owned pilots with loop resistance up to 2000ohms to protect 2 ended feeder circuits up to 20km in length. Two compatible relays are used as a pair with one relay connected to current transformers at each end of the feeder respectively. The Solkor R/Rf relays do not require an auxiliary DC supply.

## Function Overview

- High transient stability.
- High speed operation.
- Low phase and earth fault settings.
- Little or no setting variation with pilot length
- Test points at relay fascia
- Bleed-off up to 20% of rated current
- Easily reconnected as R or Rf mode
- Option of 15kV pilot isolation
- Option of pilot supervision
- Option of intertripping through the same pilot pair

## Additional Options

### 15kV Isolation

The Solkor R/Rf relay has an insulation level of 5kV between pilot connections and the local ground to withstand voltages induced on the pilot cable due to coupling with the fault current and to withstand differential ground voltages caused by the flow of fault current. Experience has shown that 5kV insulation is usually adequate for most distribution feeders.

For higher voltage systems where feeders may be longer and fault levels higher, an additional external isolation transformer is available for use with the relay in Rf mode to increase the voltage withstand to 15kV.

5kV systems may be suitable for higher voltage systems where fault levels are low or feeder lengths are short. One isolation transformer is fitted at each end of the pilot circuit. Tappings at the transformers can be utilised to allow pilots with inter-core capacitance up to 4µF can be used compared to the 0.8µF limit imposed by the 5kV standard arrangement.

### Pilot supervision

Communication via the pilots between the relay pair is essential for correct operation of the Current Differential protection system.

Additional external Pilot Supervision equipment can be supplied to detect pilot cable open circuit which can lead to protection operation or short circuit pilots which will greatly reduce the sensitivity of the relays under subsequent fault conditions.

Pilot supervision will not block relay operation but will provide an alarm. Pilot Supervision is available to suit the 5kV or 15kV insulation level of the scheme.

### Overcurrent Guard

Solkor relay trip contacts can be connected in series with those of an Overcurrent Guard relay driven from the same current transformers to avoid operation for damaged pilots during normal load levels.

The electromechanical B69 can be used for this which will provide variable settings without an auxiliary supply.

Alternatively, a numeric relay from the Argus range can be used which will have negligible additional AC burden on the current transformer and can be used to add the waveform recording functionality to the traditional Solkor scheme.

## Intertripping

---

The current differential system will naturally issue a trip at both ends for an in zone fault. Additional Intertripping equipment can also be supplied which utilises the pilot connection to initiate a protection operation at the remote end. This is generally used to cause a trip for an out of zone fault. There are 3 different methods to achieve this and their application depends on the fault current available for the out of zone fault.

Firstly the pilot loop can be open circuited to allow the remote end to operate on its measured current. To ensure positive operation of the remote end relay, the current should be at least twice the normal fault setting.

Secondly, the local end summation transformer can be short circuited to allow the remote end to operate on its measured current but with the local end connected in shunt. This can be successful with R mode where settings are raised to 4x normal settings but with Rf mode this can be up to 10x normal settings and this current is often not available.

Thirdly Injection intertripping can be used whereby the pilots are disconnected from the local relay and an AC signal, produced by an inverter, is injected to force the remote end to operate. This method will provide a successful intertrip regardless of the remote relay current level and can be applied on radial networks.

## Typical Equipment Options and Schemes

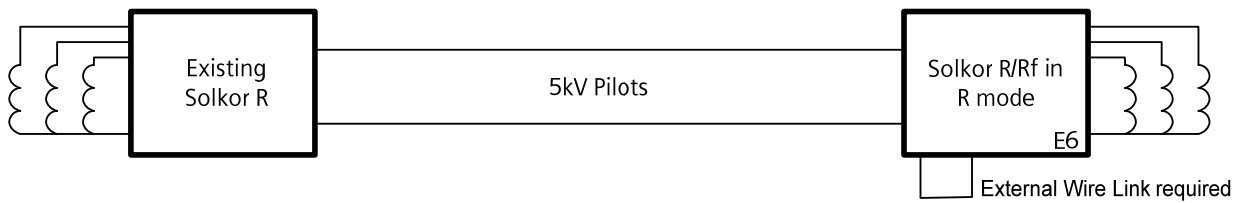

Fig 1. Installation with existing Solkor R Relay

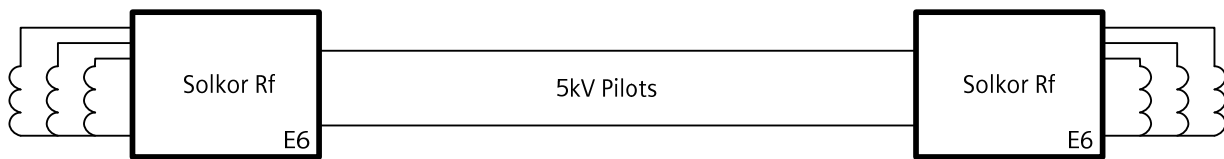

Fig 2. Standard 5kV Plain Solkor Rf

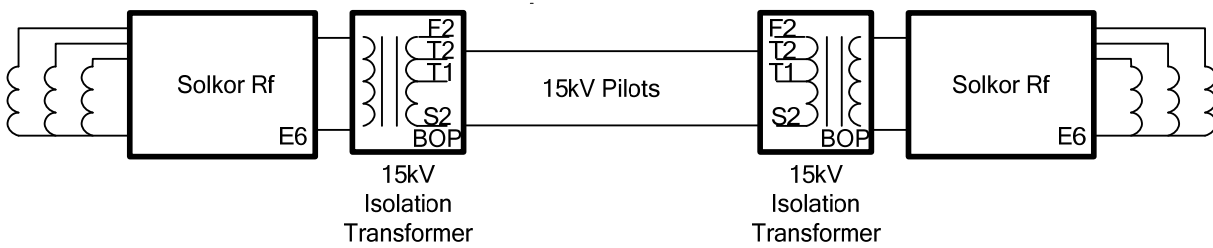

Fig 3. Standard 15kV Plain Solkor Rf

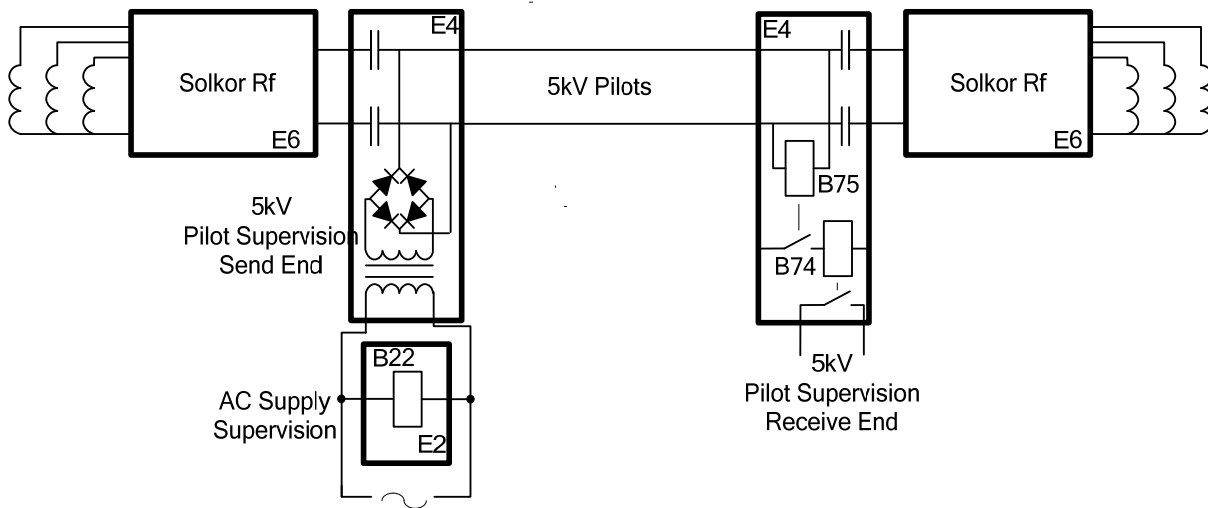

Fig 4. 5kV Solkor Rf with pilot Supervision

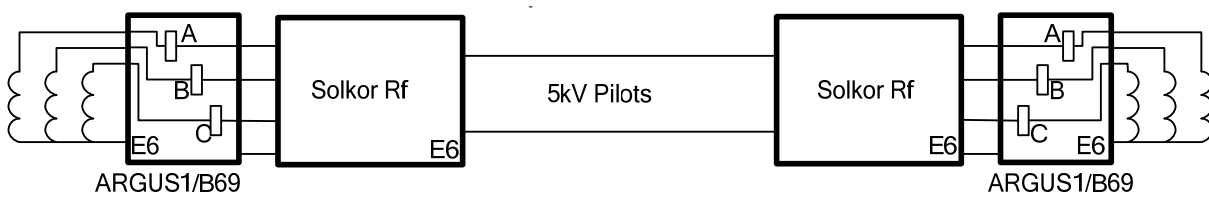

Fig 5. 5kV Plain Solkor Rf with Overcurrent Guard

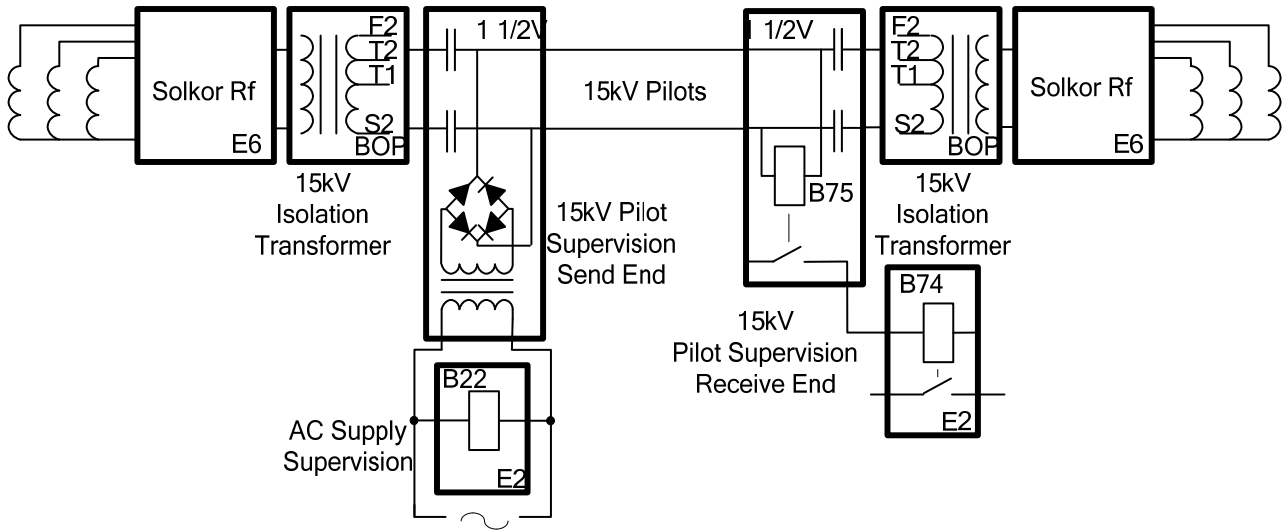

Fig 6. 15kV Solkor Rf with Pilot Supervision

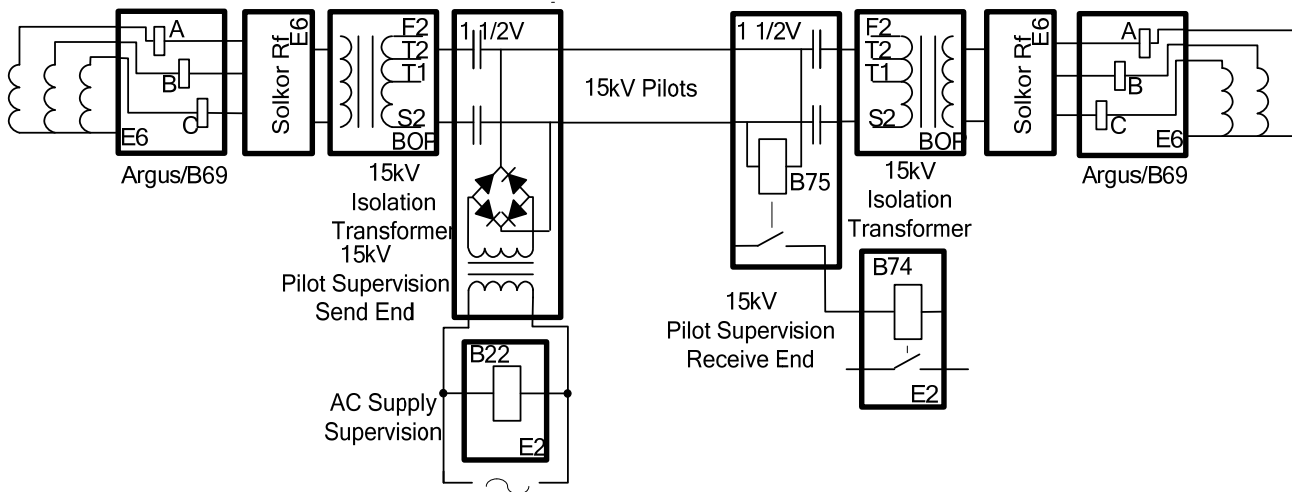

Fig 7. 15kV Solkor Rf with Pilot Supervision and Overcurrent Guard

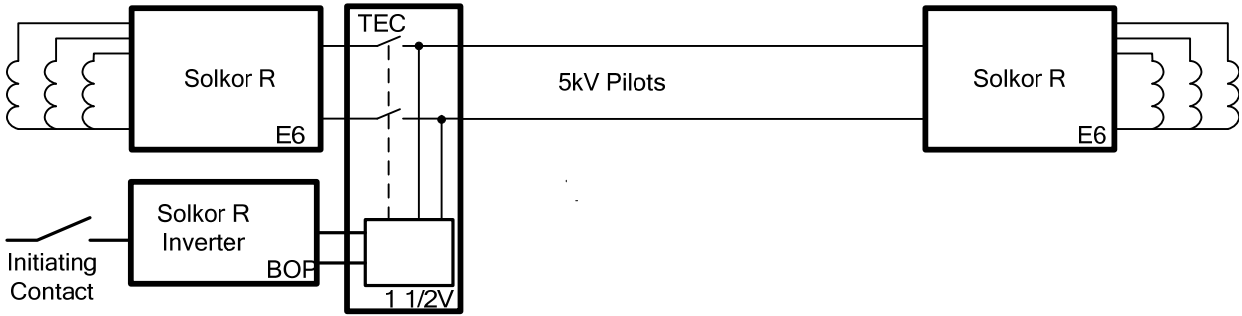

Fig 8. 5kV Solkor R Mode with One Way Injection Intertripping

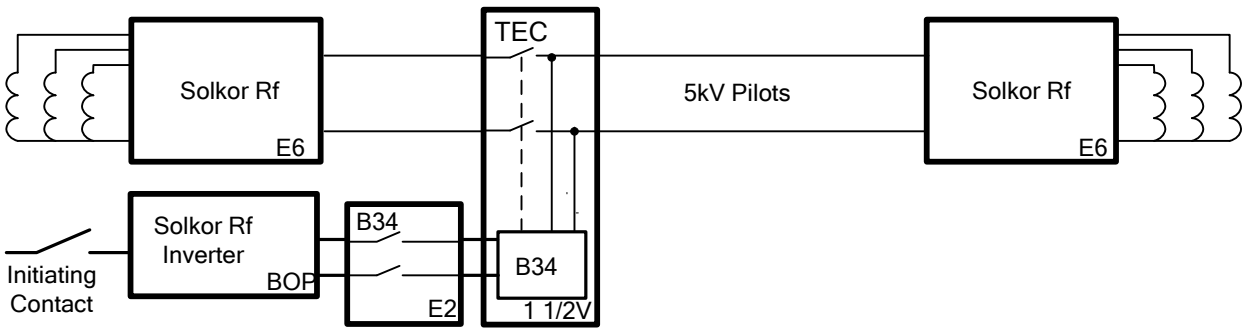

Fig 9. 5kV Solkor Rf Mode with One Way Injection Intertripping

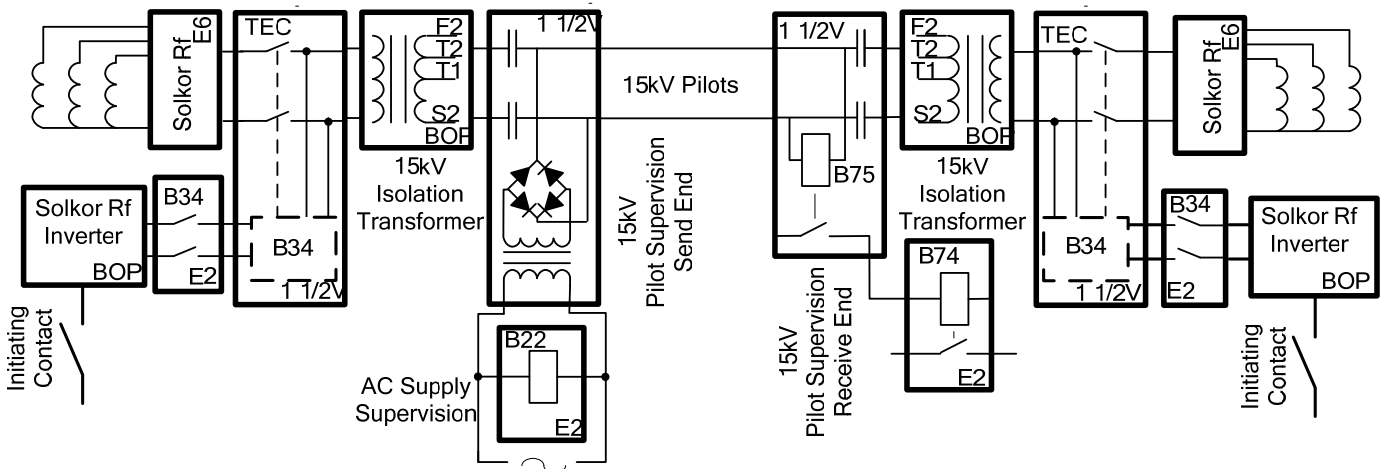

Fig 10. 15kV Solkor Rf with Pilot Supervision and 2 Way Injection Intertripping

## Service Conditions and performance data

### Application Requirements

Number of Pilot cores required 2

### Pilot Requirements

	R Mode	Rf Mode	Rf mode with 15kv Transf.		
			Tap 1	Tap 0.5	Tap 0.25
Max. Loop Resistance	1000 $\Omega$	2000 $\Omega$	1780 $\Omega$	880 $\Omega$	440 $\Omega$
Max. Inter core Capacitance	2.5 $\mu$ F	0.8 $\mu$ F	1 $\mu$ F	2 $\mu$ F	4 $\mu$ F

### Pilot Current and Voltage

	R Mode	Rf Mode	Rf mode with 15kv Transf.		
			Tap 1	Tap 0.5	Tap 0.25
Peak Voltage applied to pilots under fault conditions	300v	450v	450v	330v	225v
Maximum current carried by pilots under fault conditions	200mA	250mA	250mA	380mA	500mA

### Maximum Primary Line Capacitive Charging Current.

Solidly Earthed System, 1/3 times the most sensitive earth fault setting

Resistance Earthed System, 1/9 times the most sensitive earth fault setting

## Mechanical Durability

Vibration, relays comply with BS142 section 2.1 Category S2. Shock, relays withstand 20G shock or impact on the panel without operating. Operation/mechanical life, relays will withstand in excess of 10,000 operations.

## Electrical Performance

### Characteristic Energising Quantities

Rated Current (In)	0.5A 1A 2A 5A 6.67A
--------------------	---------------------------------

Rated Frequency (fn)	Operating Range
50 Hz	47Hz to 52Hz
60Hz	57Hz to 62Hz

### Insulation

Between pilot circuit and all other independent circuits and earth	5kV rms
Between all external terminal and earth	2kV rms
Between terminals of independent circuits	2kV rms
Across normally open contacts	1kV rms

### Isolation Transformer

Between pilot circuit terminals and all other terminals and earth	15kV rms
---	----------

### Maximum through fault condition for stability 50x rated current

Thermal Withstand (AC current)	Multiple of rated current
Continuous	2x
20 minutes	2.8x
10 minutes	3.5x
5 minutes	4.7x
3 minutes	6.0x
2 minutes	7.3x
3 seconds	60x
1 second	100x limited to 400A

Operating Time	R Mode	5kV Rf Mode	15kV Rf Mode
3x fault setting	60ms	50ms	45ms
5x fault setting	55ms	45ms	40ms
10x fault setting	50ms	45ms	40ms

Indication	Hand Reset Flag
Contact Arrangement	3 N/O
Contact Rating	Make and carry for 0.2s a burden of 6600VA with a maximum of 30A

## Environmental

### Temperature

IEC 60068-2-1/2

Type	Level
Operating Range	-10 °C to +55 °C
Storage range	-25 °C to +70 °C

### Humidity

IEC 60068-2-3

Type	Level
Operational test	56 days at 40 °C and 95 % relative humidity

### IP Ratings

Type	Level
Installed with cover	IP 51

### Pilot Supervision Equipment

Auxiliary Supply	
Send End	110/220/240V ac 50/60Hz
Receive End	30V dc 50V dc 125V dc 240V dc

### Burdens

AC Supervision Supply	10VA approx.
AC supply fail relay	3 to 5VA
Receive Repeat Relay	1W

### Contact Arrangements

Pilot Supervision Relay(B75)	1NO self reset
Repeat relay B74	2NO & 2NC
Supervision supply fail relay	2NO & 2NC

### Contact Ratings

#### Type B22, B74 and B75

Make & Carry Continuously	1500VA ac or 1500W dc within limits of 660V and 3A. Make and carry 8A for 3 secs or 16 for 1 second.
Break	300VA ac or 75W dc (inductive L/R 0.04) within limits of 250V and 5A
Indication	Flag indicators shown on de-energisation

Supervision supply fail relay (B22)	Hand Reset Flag
Receive Repeat Relay	Self Rest Flag

## Injection Intertripping

Rating Vx, 110-125V dc

Burden 1A at 125V dc full output  
400mA with economy resistor

## Settings

Primary fault settings with insulation between pilot circuits and other terminals and earth 15kV; typical current transformers and zero pilot capacitance are given below. Values are expressed as percentages of the current transformer rating.

Fault Type	Fault Setting							
	5kV scheme				15kV scheme (Rf mode only)			
	Nominal		Typical		Nominal		Typical	
	N1	N	N1	N	N1	N	N1	N
A-E	16	22	18	25	22	31	25	35
B-E	18	27.5	21	32	26	39	30	44
C-E	22	37	25	42	31	52	35	59
A-B	110		125		155		177	
B-C	110		125		155		177	
C-A	55		62		77.5		88.5	
3P	63		72		89		101	

The addition of Pilot Supervision will increase the nominal settings by up to 20%.

## Current Transformer Requirements

	R mode	Rf mode
Maximum output of CT required to operate relay	1.2VA	3VA

The main requisite is that the saturation voltage of the current transformers should not be less than that given by the formula:

$$V_k = \frac{50}{I_n} + \frac{I_F}{N} (R_{CT} + 2R_L)$$

Where  $I_n$  = Rated current of Solkor Rf relay.  
 $I_F$  = Primary current under maximum steady state THROUGH FAULT conditions.  
 $N$  = Current Transformer ratio.  
 $R_{CT}$  = Secondary resistance of the current transformer  
 $R_L$  = Lead resistance between the current transformers and the Solkor R/Rf, per phase.

For the above purpose the saturation voltage i.e. the knee point of the magnetising curve, may be taken as that point on the curve at which a 10% increase in output voltage requires 50% increase in magnetising current.

To ensure good balance of the protection the current transformers at the two ends should have identical turns ratios. Close balance of the ratio is provided by current transformers to IEC60044: pt1, class px, whose ratio error is limited to  $\pm 0.25\%$  and these CTs are recommended to meet the above requirements.

It is recommended that no other burdens should be included in the current transformer circuit, but where this cannot be avoided the additional burden should be added to those listed when determining the current transformer output voltage required.

In addition to the above, the secondary magnetising currents of the current transformers at different ends of the feeder should normally not differ by more than  $I_n/20$  amperes for output voltages up to  $50/I_n$  volts where  $I_n$  = rated current of Solkor Rf relay. This criterion is applied to quantify matching of the transient response of the two CTs so that relay operations do not occur due to differing responses of the CTs to normal load switching or the incidence and clearance of out of zone faults. This condition is usually easily satisfied by modern CTs of similar size since the magnetising current is usually a lower value. Care should be taken when applying a new CT to be paired with existing CT and also when interposing CTs are required to match CT ratios.

## Case Dimensions

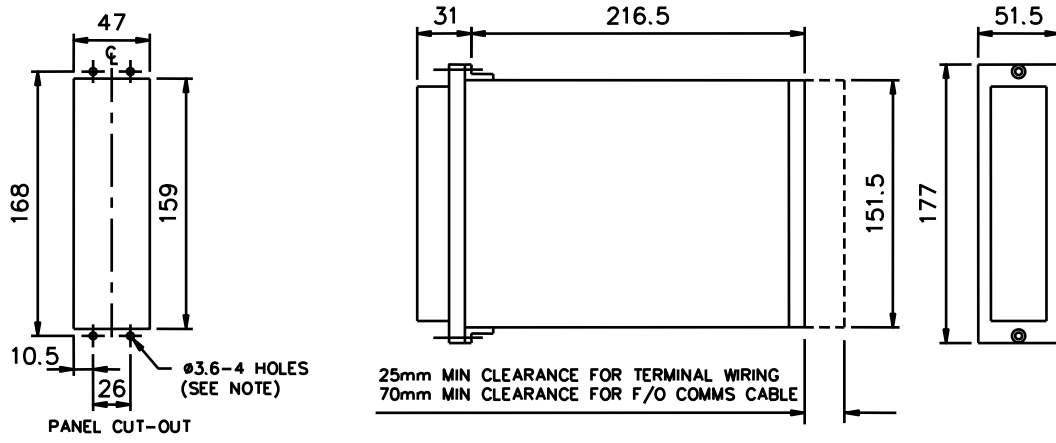

Fig 11. E2 Case

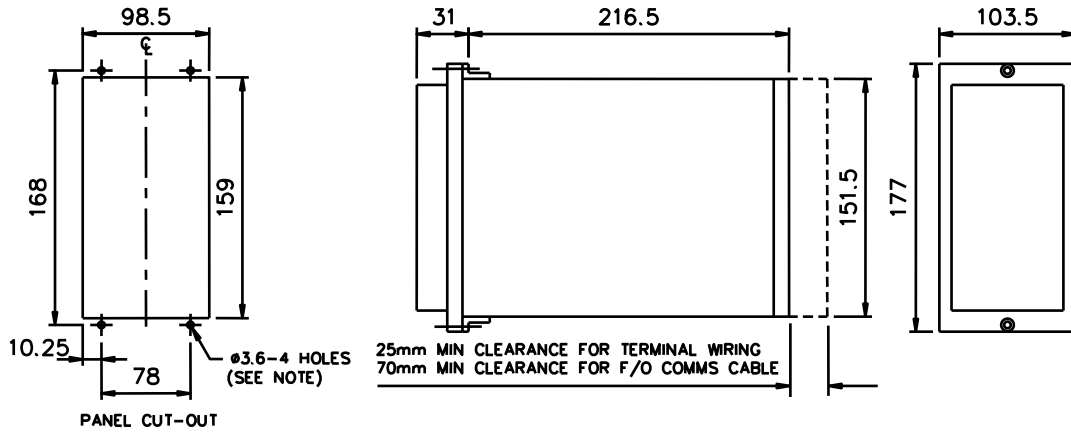
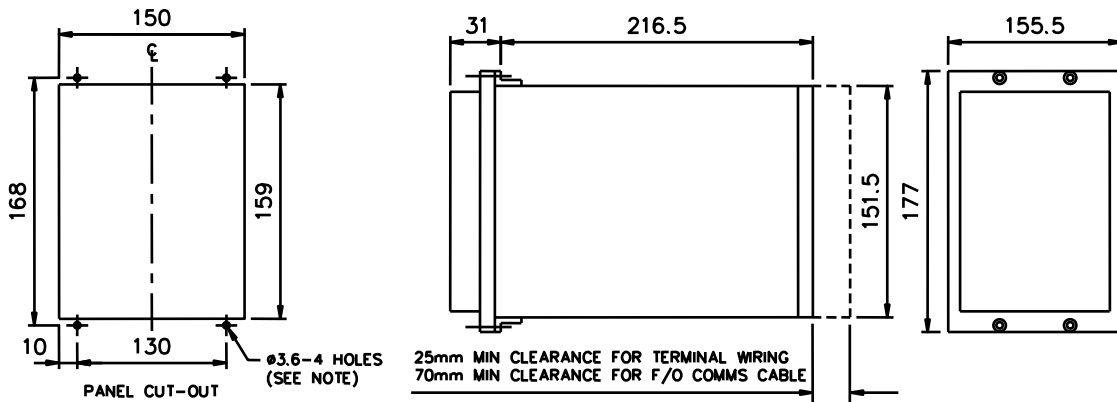

Fig 12. E4 Case



**NOTE:**  
 THE ø3.6 HOLES ARE FOR M4 THREAD FORMING (TRILOBULAR) SCREWS. THESE ARE SUPPLIED AS STANDARD AND ARE SUITABLE FOR USE IN FERROUS/ALUMINIUM PANELS 1.6mm THICK AND ABOVE. FOR OTHER PANELS, HOLES TO BE M4 CLEARANCE (TYPICALLY ø4.5) AND RELAYS MOUNTED USING M4 MACHINE SCREWS, NUTS AND LOCKWASHERS (SUPPLIED IN PANEL FIXING KIT).

Fig 13. E6 Case



# Connection Diagrams

Solkor R/Rf

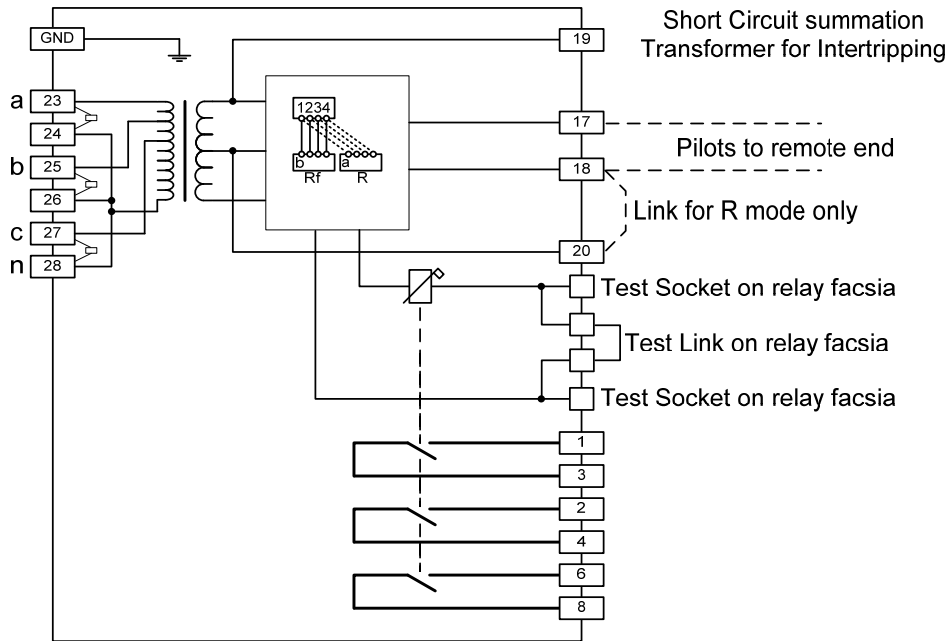

5kV Pilot supervision Send End

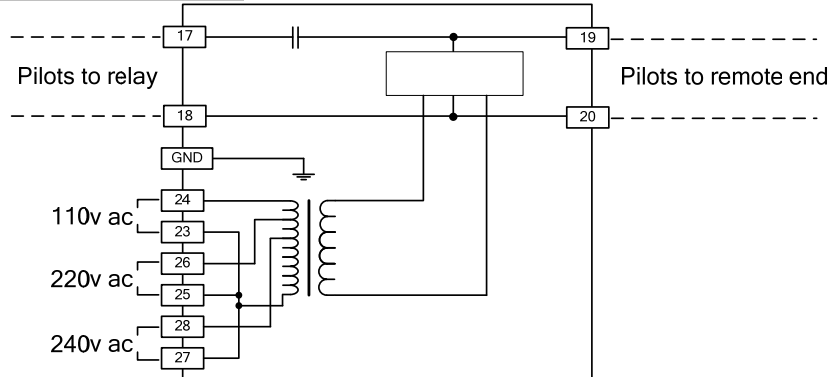

15kV Pilot supervision Send End (Vedette case)

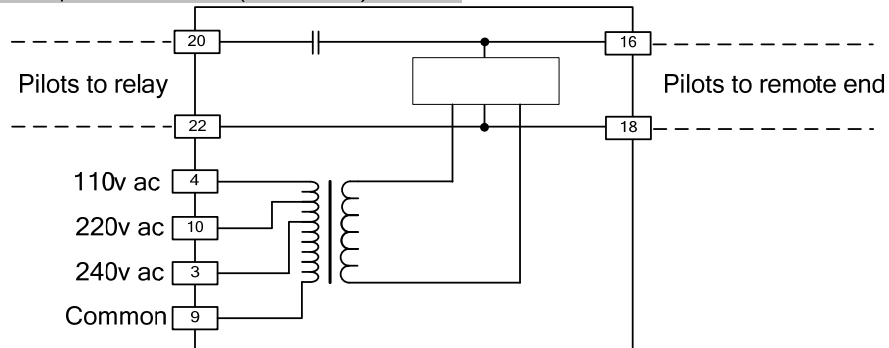

**5kV Pilot Supervision Receive End**

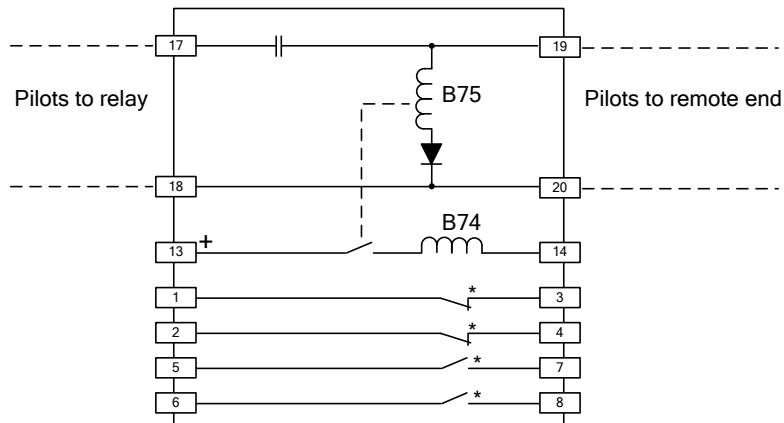

\* contacts may be 2M2B as shown or 4M or 4B

**15kV B75 Pilot Supervision Receive Relay**

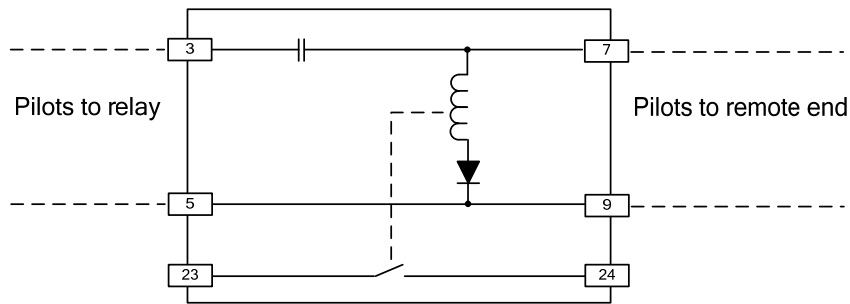

**B74 Repeat Relay for 15kV Pilot Supervision Scheme**

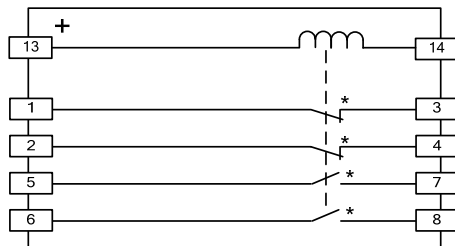

\* contacts may be 2M2B as shown or 4M or 4B

**B22 Power Supply Supervision Relay for Pilot Supervision Scheme**

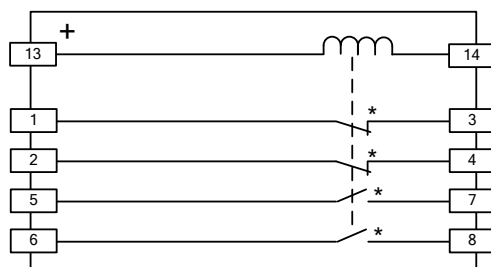

\* contacts may be 2M2B as shown or 4M or 4B

**B34 Delayed Pick-up Relay for Solkor Rf Intertripping**

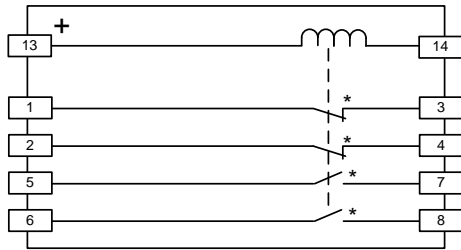

\* contacts may be 2M2B as shown or as below

	1-3	2-4	5-7	6-8
4M	M	M	M	M
3M1B	M	B	M	M
2M2B	B	B	M	M
1M3B	B	B	M	B
0B	B	B	B	B

**TEC Relay for Solkor Rf 2 stage Intertripping**

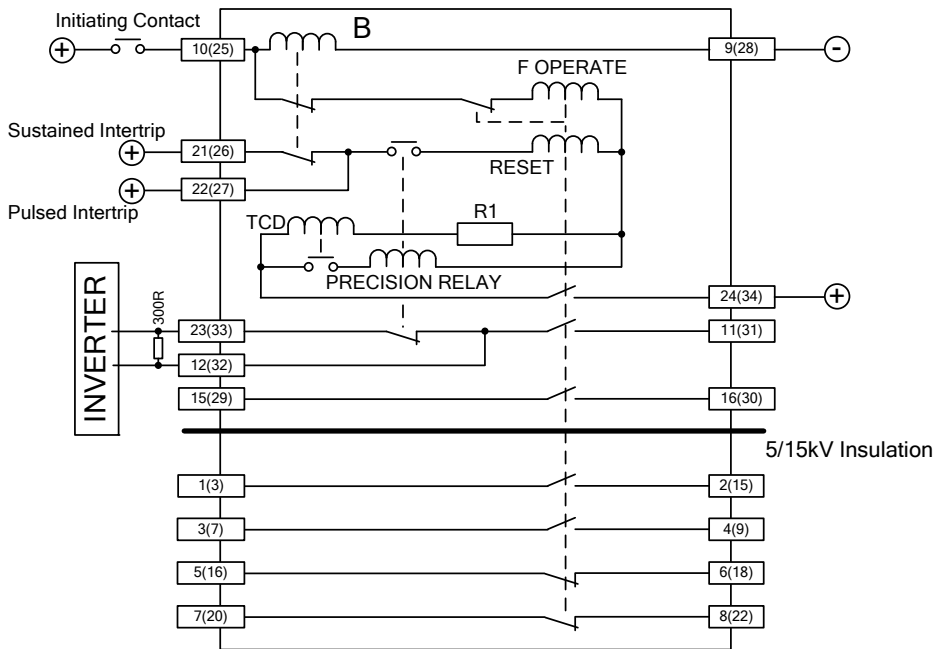

Terminal numbers are shown as 5kV(15kV)

**Inverter for Injection Intertripping**

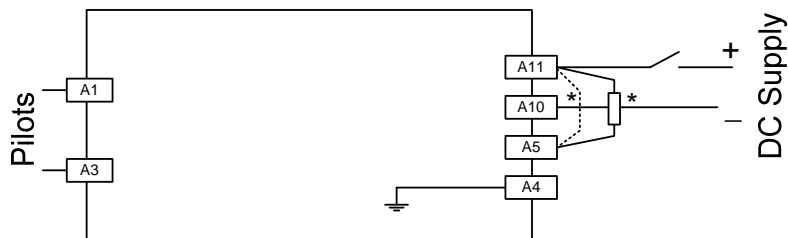

\* Wire link required between A5 to A11 for pulsed intertrip.  
 300ohm, >18W Economy resistor required between A5 \* A11 for sustained Intertrip

# Ordering Information - Solkor R/Rf 7PG21

Product description	Variants	Order No.
---------------------	----------	-----------

## Solkor R/Rf

Pilot wire current differential feeder protection.

Relay type

Solkor R/Rf relay

Solkor R/Rf equipment

Solkor R/Rf - Circulating current feeder protection

Contact operation

Self reset contacts

Contact arrangement – NO

3 NO

Contact arrangement NC

0 NC

Number of contacts

Three

Contact type

NO (Standard) / NC (Standard)

Solkor mode

Solkor Rf <sup>2)</sup>

Solkor R

Housing size

Case size E6 (4U high)

Rating

0.5A AC

1A AC

2A AC

5A AC

6.67A AC

7 P G 2 1 □ □ - □ □ □ □ □ □ - □ □ □ 0

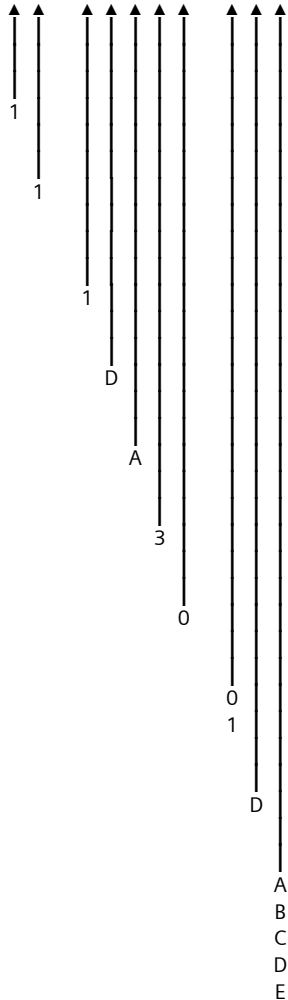

## Solkor R/Rf

15kV isolation transformer for use with Solkor Rf.

Relay type

Solkor R/Rf - Circulating current feeder protection scheme

Solkor R/Rf equipment

Solkor Rf – 15kV isolation transformer

Housing size

Special

7 P G 2 1 □ □ - 0 A A 0 0 - 0 □ A 0

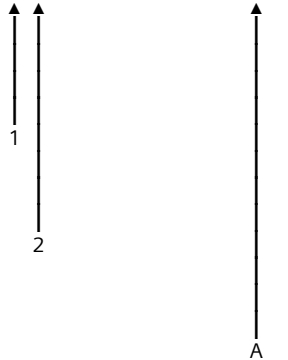

1) For pilot insulation of between 5kV and 15kV, SOLKOR Rf mode only, order 7PG2112-0AA00-0AA0 isolating transformer with the relay at each feeder-end  
 2) Relay is set in Solkor Rf mode as default

# Ordering Information – Solkor Pilot Supervision 7PG21

Product description	Variants	Order No.
<p><b>Supply transformer rectifier unit</b></p> <p>For use with Solkor R/Rf relay, pilot supervision send end.</p> <p><u>Relay type</u> Supply Transformer/Rectifier unit (send end) <sup>1)</sup></p> <p><u>Type of Flag</u> No flag</p> <p><u>Contact Arrangement - NO</u> 0 NO</p> <p><u>Contact Arrangement – NC</u> 0 NC</p> <p><u>Number of contacts</u> None</p> <p><u>Contact type</u> None</p> <p><u>Insulation level</u> 5kV 15kV 15kV, front connection</p> <p><u>Housing size</u> Case size E4 (4U high) Case size C1 1/2 Vedette</p> <p><u>Rating</u> <sup>1)</sup> 110/220/240V AC, 50/60Hz</p>		<p>7 P G 2 1 □ 0 - 0 A A 0 0 - □ □ □ 0</p> <p>↑ ↑ ↑ ↑ ↑ ↑ ↑ ↑ ↑ ↑ ↑ ↑</p> <p>2</p> <p>0</p> <p>A</p> <p>A</p> <p>0</p> <p>0</p> <p>1 C</p> <p>2 W</p> <p>3 W</p> <p>C</p> <p>W</p> <p>A</p>

<sup>1)</sup> Supply Transformer/Rectifier unit (send end), ratings 110/220/240V ac, 50/60Hz.

<sup>2)</sup> For required supply supervision relay B22, see 7PG213\*.

<sup>3)</sup> For optional guard relay B69, one 3 phase set (two sets required one at each feeder end), see 7PG217\*.

# Ordering Information – Solkor Pilot Supervision 7PG21

Product description	Variants	Order No.
<p><b>B22-AC</b></p> <p>For use with Solkor R/Rf relay, pilot supervision send end.</p> <p><u>Relay type</u> Supply supervision (B22-AC)</p> <p><u>Type of flag</u> Hand reset reverse acting flag</p> <p><u>Contact operation</u> Self reset contacts</p> <p><u>Contact arrangement – NO</u> 2 NO</p> <p><u>Contact arrangement NC</u> 2 NC</p> <p><u>Number of contacts</u> Four</p> <p><u>Contact type</u> NO (Standard) / NC (Standard)</p> <p><u>Frequency</u> 50Hz 60Hz</p> <p><u>Housing size</u> Case size E2 (4U high)</p> <p><u>Voltage rating</u> 110V AC 220V AC 240V AC</p>		<p>7 P G 2 1 □ □ - □ □ □ □ □ □ - □ □ □ 0</p>

# Ordering Information – Solkor Pilot Supervision 7PG21

Product description	Variants	Order No.
<p><b>B75/74</b></p> <p>For use with Solkor R/Rf relay, pilot supervision receive end (5kV).</p>	<p><u>Relay type</u> <sup>1)</sup> Receive and repeat (B75/B74)</p> <p><u>Type of flag</u> Self reset reverse acting flag</p> <p><u>Contact operation</u> Self reset contacts</p> <p><u>Contact arrangement – NO</u> 0 NO 2 NO 4 NO</p> <p><u>Contact arrangement NC</u> 0 NC 2 NC 4 NC</p> <p><u>Number of contacts</u> Four</p> <p><u>Contact type</u> NO (Standard) / NC (Standard)</p> <p><u>Insulation level</u> 5kV</p> <p><u>Housing size</u> Case size E4 (4U high)</p> <p><u>Voltage rating</u> 24V DC 30V DC 50V DC 125V DC 240V DC</p>	<p>7 P G 2 1 □ □ - □ □ □ □ - □ □ □ 0</p>

<sup>1)</sup> Option selection for B74 element, B75 (3mA, 1NO/0NC) element included as standard

## Ordering Information – Solkor Pilot Supervision 7PG21

Product description	Variants	Order No.
<p><b>B75</b></p> <p>For use with Solkor R/Rf relay, pilot supervision receive end (15kV).</p>	<p><u>Relay type</u> Receive (B75)</p> <p><u>Type of flag</u> Self reset reverse acting flag</p> <p><u>Contact operation</u> Self reset contacts</p> <p><u>Contact arrangement – NO</u> 1 NO</p> <p><u>Contact arrangement NC</u> 0 NC</p> <p><u>Number of contacts</u> One</p> <p><u>Contact type</u> NO (Standard) / NC (Standard)</p> <p><u>Insulation level</u> 15kV 15kV, front connection</p> <p><u>Housing size</u> Case size C1 1/2 Vedette</p> <p><u>Current setting</u> 3mA</p>	<p>7 P G 2 1 □ □ - □ □ □ □ - □ □ □ 0</p>

# Ordering Information – Solkor Pilot Supervision 7PG21

Product description	Variants	Order No.
<p><b>B74</b></p> <p>For use with Solkor R/Rf relay, pilot supervision receive end (15kV).</p>	<p><u>Relay type</u> Receive repeat (B74)</p> <p><u>Type of flag</u> Self reset reverse acting flag</p> <p><u>Contact operation</u> Self reset contacts</p> <p><u>Contact arrangement – NO</u> 2 NO</p> <p><u>Contact arrangement NC</u> 2 NO</p> <p><u>Number of contacts</u> Four</p> <p><u>Contact type</u> NO (Standard) / NC (Standard)</p> <p><u>Insulation level</u> 15kV</p> <p><u>Housing size</u> Case size E2 (4U high)</p> <p><u>Voltage rating</u> 24V DC 30V DC 50V DC 125V DC 240V DC</p>	<p>7 P G 2 1 □ □ - □ □ □ □ - □ □ □ 0</p>

# Ordering Information – Solkor Pilot Supervision 7PG21

Product description	Variants	Order No.
<p><b>B69</b></p> <p>For use with Solkor R/Rf relay as overcurrent/earth fault guard.</p> <p><u>Relay type</u> Three pole overcurrent/earth fault guard (B69) (3P O/C or 2P O/C+E/F)</p> <p><u>Type of flag</u> No flag</p> <p><u>Contact operation</u> Self reset contacts</p> <p><u>Contact arrangement – NO</u> 2 NO</p> <p><u>Contact arrangement NC</u> 0 NC</p> <p><u>Number of contacts</u> Two</p> <p><u>Contact type</u> NO (Standard) / NC (Standard)</p> <p><u>Current rating</u> 1A 5A</p> <p><u>Housing size</u> Case size E6 (4U high)</p> <p><u>Current setting</u> Outer elements 50-200%, Inner element 50-200% Outer elements 50-200%, Inner element 10-40% Outer elements 50-200%, Inner element 20-80%</p>		<p>7 P G 2 1 □ □ - □ □ □ □ - □ □ □ 0</p>

<sup>1)</sup> Optional B69 Guard relays, one 3 phase set. (Two sets required one at each feeder end)

# Ordering Information – Solkor Injection Intertripping 7PG21

Product description	Variants	Order No.
<p><b>Inverter</b></p> <p>Injection intertripping equipment for intertripping of remote Solkor R/Rf relays over pilot wires.</p>	<p><u>Relay type</u> SOLKOR injection intertripping (Inverter)</p> <p>Injection intertripping equipment <sup>2)</sup> Inverter DC - Solkor R Inverter AC - Solkor Rf</p> <p><u>Insulation level</u> 15kV</p> <p><u>Housing size</u> Special</p> <p><u>Voltage rating</u> 125V DC</p>	<p>7 P G 2 1 □ □ - 0 A A 0 0 - □ □ □ 0</p> <p>↑ ↑ ↑ ↑ ↑ ↑ ↑ ↑ ↑ ↑</p> <p>8 1 2 A E</p>
<p><b>B34</b></p> <p>Injection intertripping equipment for intertripping of remote Solkor Rf relays over pilot wires.</p>	<p><u>Relay type <sup>3)</sup></u> Solkor Rf injection intertripping (Delay)</p> <p><u>Injection intertripping equipment</u> B34</p> <p><u>Contact operation</u> Self reset contacts</p> <p><u>Contact arrangement – NO</u> 2 NO</p> <p><u>Contact arrangement NC</u> 2 NC</p> <p><u>Number of contacts</u> Four</p> <p><u>Contact type</u> NO (Standard) / NC (Standard)</p> <p><u>Insulation level</u> 5kV</p> <p><u>Housing size</u> Case size E2 (4U high)</p> <p><u>Voltage rating</u> 24V DC 30V DC 50V DC 60V DC 125V DC 240V DC</p>	<p>7 P G 2 1 □ □ - □ □ □ □ - □ □ □ 0</p> <p>↑ ↑ ↑ ↑ ↑ ↑ ↑ ↑ ↑ ↑</p> <p>8 3 1 C C 4 0 1 A</p> <p>A B C D E F</p>

1) For Solkor Injection Intertripping Send relay, select suitable TEC relay, see 7PG223\*  
 2) 'Inverter DC Solkor R' can be used as a 15kV isolated DC supply for surge proof intertripping  
 3) Option selection for B34 (5kV) delay relay, required on Solkor Rf schemes

# Ordering Information – TEC 7PG22

Product description	Variants	Order No.
<p><b>TEC</b> Intertrip send relay.</p> <p><u>Relay type</u> TEC - Intertrip send</p> <p><u>Model Type</u> Pulse or sustained intertrip Two stage intertrip</p> <p><u>Type of Flag</u> Hand reset flag</p> <p><u>Contact arrangement – NO</u> 4 NO</p> <p><u>Contact arrangement NC</u> 2 NC</p> <p><u>Number of contacts</u> Six</p> <p><u>Contact type <sup>1)</sup></u> NO (Standard) / NC (Standard)</p> <p><u>Insulation level</u> 5kV 15kV</p> <p><u>Housing size</u> Case size C1 1/2 Vedette</p> <p><u>Rating</u> 24V DC 30V DC 50V DC 60V DC 125V DC 240V DC</p>		<p>7 P G 2 2 □ □ - □ □ □ □ - □ □ □ 0</p>

<sup>1)</sup> 2 NO with standard 2kV insulation, 2 NO and 2 NC with 5kV or 15kV (option 13) insulation



Siemens Protection Devices Limited  
P.O. Box 8  
North Farm Road  
Hebburn  
Tyne & Wear  
NE31 1TZ  
United Kingdom  
Phone: +44 (0)191 401 7901  
Fax: +44 (0)191 401 5575  
Web: [www.siemens.com/energy](http://www.siemens.com/energy)

PTD 24h Customer Support  
Phone: +49 180 524 7000  
Fax: +49 180 524 2471  
E-mail: [support.energy@siemens.com](mailto:support.energy@siemens.com)  
Data is subject to change without notification.

**[www.siemens.com/energy](http://www.siemens.com/energy)**