



Reyrolle
Protection
Devices

7SG18 Solkor N

Current Differential Protection

Answers for energy

SIEMENS

7SG18 Solkor N

Current Differential Protection



Description

The Solkor technique of current differential protection was developed by Reyrolle over 50 years ago, and has formed an important part of the product range ever since. It has now progressed into a microprocessor controlled, differential feeder protection system providing complete protection for overhead lines and cable feeders.

Function Overview

- Three pole, current differential protection with two stage bias characteristic.
- Intertripping from internal or external initiation.
- Three pole, phase fault overcurrent protection - IDMTL or DTL with highsets.
- Earth fault overcurrent protection - IDMTL or DTL with highsets.
- Overcurrent protection can be configured to operate as guard and/or back-up in case of communications failure.
- Communication loop-back test modes.
- Communication link supervision.
- Trip circuit supervision.
- Circuit breaker fail protection.
- Selectable 1A / 5A current inputs.
- Ratio correction for mis-matched line current transformer ratios.
- Ability to invert current inputs to facilitate commissioning.
- Seven user-programmable output contacts.
- Up to nine user programmable status inputs with pick-up and drop-off timers.
- End to End communications via electrical or Fibre Optic channels.

Monitoring Functions

Analogue values can be displayed in primary or secondary quantities on the LCD screen. In addition the values can be obtained via the communications port.

- Local and remote end primary ammeters
- Local and remote end secondary ammeters
- Differential currents (secondary values)
- Differential starters
- Protection signalling link status
- General alarms
- Output contacts
- Status inputs
- Trip circuit healthy/failure
- Trip counter
- I² summation
- Number of waveform and event records stored
- Time and Date
- Starters
- Power on counter

Data Storage and Communication

Serial communications conform to IEC60870-5-103 or Modbus RTU protocol. Up to 254 relays may be connected in a ring network and addressed individually.

A fibre-optic communications port is provided on the rear of the relay. It is optimised for 62.5/125µm glass fibre using ST® (BFOC/2.5) bayonet connectors. Optionally an RS485 electrical connector can be provided.

Indication

- LEDs for
 - PROTECTION HEALTHY (Green)
 - INTERTRIP (Red) – an intertrip has been received
 - I²s (Yellow) – any function detects current above setting
 - TRIP (Red) – the relay has issued a trip signal
 - SIGNAL HEALTHY (Green) – the signalling link is healthy

Sequence of event records

Up to 500 events are stored and time tagged to 1ms resolution. These are available via the communications.

Fault records

The last 5 fault records are available from the relay fascia with time and date of trip, measured quantities and type of fault.

Disturbance recorder

The waveform recorder may be triggered from a protection function or external input and has a configurable pre-fault trigger. Up to 5 fault waveforms may be stored. AC current waveforms are stored together with the digital states of the status inputs and output relays.

Reydisp Evolution

Reydisp Evolution is common to the entire range of Reyrolle numeric products. It provides the means for the user to apply settings, interrogate settings, retrieve events and disturbance waveforms from the relay.

Description of Functionality

Current Differential Protection

The relay compares magnitude and phase angle of measured currents at either end of the protected feeder, it operates for faults detected within the protected zone. The three pole, phase fault differential comparators each provide two bias slopes. The first stage of bias accommodates proportional measuring errors in the system. The second stage accommodates additional spill current caused by CT saturation at high fault levels.

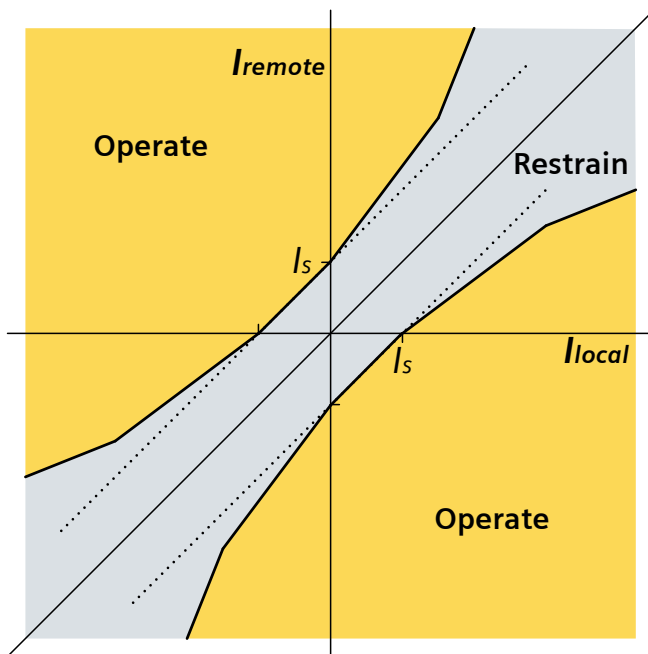

Fig 1. Differential Protection Operating Characteristic

It is not necessary to have the same CT ratios at either end of a protected feeder, since ratio compensation is settable. It is also possible to invert the current inputs to aid in commissioning.

Backup Overcurrent Protection

In addition to the differential protection, comprehensive overcurrent protection for phase and earth faults provides

back-up IDMTL and DTL characteristics in the event of a communications link failure

Guard Relays

To add security to the differential scheme it is possible to designate any of the overcurrent elements as a guard element. The appropriate overcurrent element must then operate to allow the differential element to trip.

Intertripping

Three auxiliary signalling channels are provided for intertripping.

One internal intertrip dedicated to the differential protection. Two independent intertrips which can be used for either direct or permissive intertripping from an external source.

Where an internal fault is fed largely from one end, the differential comparators at both ends operate identically, but the guard at the low current end may not pick up and so block the trip. To overcome this, an internal intertrip signal is sent which can be used at the receive end to either override the guard so allowing the differential to trip, or, operate the trip contacts directly.

Protection Signalling Channels

Four types of protection signalling channel are provided as follows:

1. RS485 level electrical link for distances up to 2km.
2. Short range optical link for distances up to 15km (typical) using multimode fibres.
3. Long range optical link for distances up to 49km (typical) using single mode fibres.
4. RS232 link to external modem for electrical link up to 10km

Fibre optic signalling interface connections are BFOC/2.5 (ST®) bayonet style connectors.

The RS485 signalling interface uses screw terminals to suit 3/32" flat blade terminals.

RS232 signalling interface for connection to the external pilot wire modem uses a male 9 pin D-type connector to suit the female connector on the end of the 1.9m long cable supplied with the pilot wire modem.

Continuous protection signalling link supervision is provided. Two test modes are included to assist with commissioning the signalling link.

In loop test mode the local transmit and receive terminals can be connected together, allowing relays at each end to be tested in isolation.

Line test mode allows the integrity of the whole signalling channel to be checked. The relay commands the remote end to 'echo' all received data back to the local end. In line test mode, the remote differential protection is suspended.

The relay will automatically account for propagation delays in the signalling channel up to a maximum of 9.5ms. For delays in excess of 9.5ms a manual offset can

be applied, with the actual delay falling within a 9.5ms window centred on the offset.

Trip Circuit Supervision

The trip circuit is monitored by a status input with the circuit breaker in both the open and closed position. This is linked to an alarm and may be configured to operate an output relay.

Circuit breaker Fail

The circuit breaker fail function may be triggered by a trip signal issued from the relay or from an external device. It operates by monitoring the line current following a trip signal and issues an alarm if the current does not stop within a specified time interval. This alarm can be used to operate an output contact to backtrip an upstream circuit breaker. A further time delay enables another backtrip stage.

Circuit Breaker Maintenance

A circuit breaker operations counters is provided. A summation of I^2 broken by the circuit breaker provides a measure of the contact erosion. Operations count and I^2 alarm levels can be set which, when reached, can be used as an input to a condition-based maintenance regime.

Technical Data

For full technical data refer to the Performance Specification of the Technical Manual.

Inputs and Outputs

Characteristic energising quantity

AC Current	Frequency
1A / 5A	50 / 60Hz

Current Inputs: Burdens

5A Phase/Earth	< 0.2VA
1A Phase/Earth	< 0.05VA

Phase/Earth Current Inputs: Thermal Withstand

Continuous	3.0 x I _n	
10 minutes	3.5 x I _n	
5 minutes	4.0 x I _n	
3 minutes	5.0 x I _n	
2 minutes	6.0 x I _n	
	1A Input	5A Input
3 Second	57.7A	230A
2 Second	70.7A	282A
1 Second	100A	400A
1 Cycle	700A	2500A

DC Auxiliary supply

Rated DC Voltage	Operating Range V dc
24/30/48V	18 to 60V
110/220V	88 to 280V

Operate State	Burden
Quiescent (Typical)	3 W
Maximum	10 W

Allowable superimposed ac component	≤ 12% of dc voltage
Allowable breaks/dips in supply (collapse to zero from nominal voltage)	≤ 20 ms

DC status input

Nominal voltage	Operating range
30V	18 - 37.5 V D C
48V	37.5 - 60 V D C
110V	87.5 - 137.5 V D C
220V	175 - 280 V D C

Attribute	Value
Min. DC Current for Operation: 30/48V 110/220V	10mA <5mA
Reset/Operate voltage ratio	≥ 90 %
Typical response time	5 ms
Typical response time when programmed to energise an output relay contact	< 15 ms
Recommended Minimum pulse duration	40ms with setting of 20ms PU delay for a.c. rejection

For relays to ES148-4 standard and 110/125 or 220/250 volt DC working a 48 volt status input is supplied for use with external dropper resistors:

Nominal Voltage	Resistor Value	Wattage
110V	2k7 ± 5%	2.5 W
220 V	8k2 ± 5%	6.0 W

Each status input has associated timers which can be programmed to give time delayed pick-up and time delayed drop-off. These timers have default settings of 20ms, thus providing rejection and immunity to an AC input signal. Status inputs will not respond to the following:-
250V RMS 50/60Hz applied for two seconds through a 0.1µF capacitor.

Discharge of a 10µF capacitor charged to maximum DC auxiliary supply voltage.

The status inputs with nominal voltage of 30 V to 54 V meet the requirements of ESI 48-4 ESI 1.

Low Burden Status Inputs

Optionally, low burden status inputs are available directly rated for 110/125Vd.c. or 220/250Vd.c. without dropper resistors. These inputs do not meet the ESI 48-4 ESI 1 requirements. Where necessary a single external resistor in parallel can be fitted to meet ESI 48-4 ESI 1 requirements.

Low Burden Status Input performance

Nominal	Operating Range	Typical burden
110, 125	87.5 to 137.5 V DC	1.75 to 3.0 mA
220, 250	175 to 280V DC	1.75 to 3.0 mA

110/125 V minimum pick-up voltage typically 50 – 60 V d.c.
220/250 V minimum pick-up voltage typically 100 – 120 V d.c.

Output relays

Carry continuously	5A ac or dc
Make and carry (L/R ≤ 40 ms and V ≤ 300V)	20A ac or dc for 0.5s 30A ac or dc for 0.2s
Breaking Capacity (≤ 5 A and ≤ 300 V): AC Resistive AC Inductive DC Resistive DC Inductive	1250 VA 250 VA at p.f. ≤ 0.4 75 W 30 W at L/R ≤ 40ms 50 W at L/R ≤ 10ms
Minimum number of operations	1000 at maximum load
Minimum recommended load	0.5 Watt minimum of 10mA or 5V

Mechanical

Vibration (Sinusoidal)

IEC 60255-21-1 Class I

Vibration response	0.5gn
Vibration endurance	1.0gn

Shock and Bump

IEC 60255-21-2 Class I

Shock response	5gn, 11ms
Shock withstand	15gn, 11ms
10 gn, Bump test, 16ms	10gn, 16ms

Seismic

IEC 60255-21-3 Class I

Seismic Response	1gn
------------------	-----

Mechanical Classification

Durability	In excess of 10 ⁶ operations
------------	---

Electrical Tests

Insulation

IEC 60255-5 rms levels for 1 minute

Between all terminals and earth for 1 minute	2.0 kV rms
Between independent circuits for 1 minute	2.0 kV rms
Across normally open contacts for 1 minute	1.0 kV rms

Transient overvoltage

IEC 60255-5

Between all the terminals and earth or between any two independent circuits without damage or flashover	5 kV 1.2/50 μs 0.5 J
---	----------------------------

High frequency disturbance

IEC 60255-22-1 class III

2.5kV longitudinal mode 1.0kV transverse mode	< 3% deviation
--	----------------

Electrostatic Discharge

IEC 60255-22-2 class III

8kV, Contact discharge	≤ 5% variation
------------------------	----------------

Radio frequency interference

IEC60255-22-3

10 V/m, 80 to 1000 MHz	≤ 5% variation
------------------------	----------------

Fast transient

IEC 60255-22-4 class IV

4kV, 5/50ns, 2.5 kHz, repetitive	≤ 3% variation
----------------------------------	----------------

Conducted RFI

IEC 60255-22-6 class IV

10 V, 0.15 to 80 MHz	≤ 5% variation
----------------------	----------------

Conducted Limits

IEC 60255-25

Frequency Range	Limits dB(μV)	
	Quasi-peak	Average
0.15 to 0.5 MHz	79	66
0.5 to 30 MHz	73	60

Radiated Limits

IEC 60255-25

Frequency Range	Limits at 10 m Quasi-peak, dB(μV/m)
30 to 230 MHz	40
230 to 10000 MHz	47

Environmental

Temperature

IEC 60068-2-1/2

Operating range	10°C to +55°C
Storage range	25°C to +70°C

Humidity

IEC 60068-2-3

Operational test	56 days at 40°C and 93% RH
------------------	----------------------------

Protection Elements

General Accuracy

Reference Conditions	
General	IEC 60255-3
Current settings	100% of I _n
Current input	IDMTL: 2 to 30 xIs DTL: 5 xIs
Auxiliary supply	Nominal
Frequency	50 Hz
Ambient temperature	20 °C

General Settings	
Transient overreach of highset/lowset (X/R = 100)	≤ 5 %
Disengaging time (see note)	< 42 ms
Overshoot time	< 40 ms

Note. Output contacts have a programmable minimum dwell time, after which the disengaging time is as above.

Accuracy Influencing Factors

Temperature	
-10 °C to +55 °C	≤ 5 % variation
Frequency	
47 Hz to 52 Hz	Level: ≤ 5 % variation
57 Hz to 62 Hz	
	Operating time: ≤ 5 % variation
Harmonic content	
Frequencies to 550 Hz	≤ 5 % variation

Current differential

Level	
Phase setting	Phase setting
Phase bias 1	Phase bias 1
Phase bias 2	Phase bias 2

The Magnitude and Angle of the currents are compared in separate comparators. Typical operating threshold characteristics are shown below

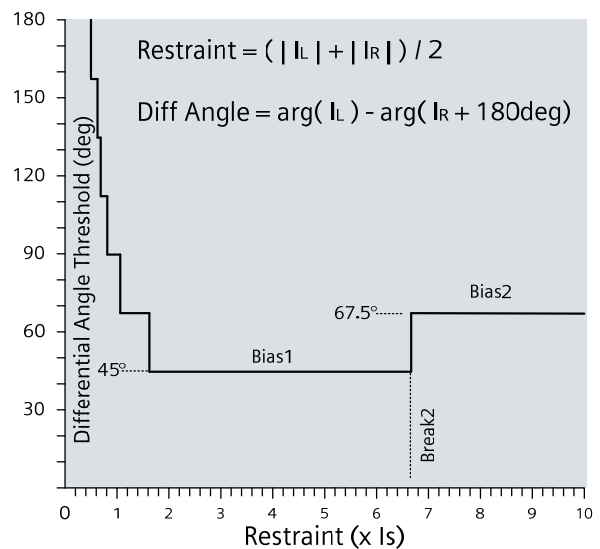
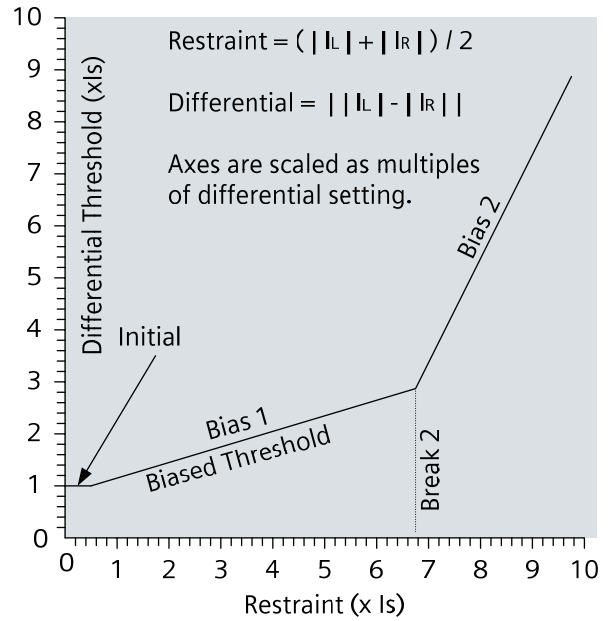

Fig 2. Differential Protection Operating Characteristic

The error limits on these diagrams are as follows:

Operate Levels	
Differential Magnitude – Initial Threshold	± 10% or ± 10mA
Differential Magnitude – Biased Threshold	Biased threshold ±(10% of Restraint) or ± 10mA
(At low levels)	For Restraint < 1.6Is +ve limit – Biased threshold + 10% or +10mA -ve limit – Initial threshold - 10% or -10mA
Differential Comparator Angle Threshold	± 5°

Differential and Intertrip operate times are given by:

$$t = t_0 + t_d$$

Where

t_0 is the base operating time

t_d is the Differential Delay time

The base operating time depends on the communications bit rate.

Operate Times	
Differential base operate time ($I_{diff} > 10 I_s$)	$\leq 40\text{ms}$ (38400 baud) $\leq 50\text{ms}$ (19200 baud)
Differential Delay Time	$\pm 1\%$ or $\pm 10\text{ms}$

Overcurrent protection

Characteristic	
Setting	IEC Normal Inverse (NI) IEC Very Inverse (VI) IEC Extremely Inverse (EI) IEC Long Time Inverse, (LTI) DTL
No. of elements	1
Level	
Setting Range I_s	0.1, 0.15...2.5 x I_n
Accuracy	Operate: 105% I_s , $\pm 4\%$ or $\pm 1\% \times I_n$ Reset $\geq 95\%$ of operate current
Repeatability	$\pm 1\%$
IDMTL Time Multiplier	
Setting	0.025, 0.05...1.6
Accuracy	$\pm 5\%$ or $\pm 30\text{ms}$
Repeatability	$\pm 1\%$ or $\pm 5\text{ms}$
DTL Delay	
Setting	0.00 to 20.00 sec
Accuracy	$\pm 10\text{ms}$
Repeatability	$\pm 5\text{ms}$
Reset delay	
Setting	0 to 60 sec
Accuracy	$\pm 1\%$ or $\pm 10\text{ms}$
Repeatability	$\pm 1\%$ or $\pm 5\text{ms}$

DTL	
No. of elements	3
Level	
Setting Range I_s	0.1 to 52.5 x I_n
Accuracy	Operate: 100% I_s , $\pm 5\%$ or, $\pm 10\text{mA}$ Reset $\geq 95\%$ of operate current
Repeatability	$\pm 1\%$
DTL Delay	
Setting	0.00 to 20.00 sec
Accuracy	$\pm 5\text{ms}$
Repeatability	$\pm 1\%$ or $\pm 5\text{ms}$

Earth fault protection

As overcurrent protection.

Circuit breaker failure (50BF)

Operate Level	
Phase Fault setting I_s	Off, 0.1, 0.15 ... 1.0 x I_n
Earth Fault setting I_s	Off, 0.1, 0.15 ... 1.0 x I_n
Accuracy	Operate: 100% I_s , $\pm 5\%$ or $\pm 1\% \times I_n$ Reset 95% of I_{op} $\pm 5\%$ or $\pm 1\% \times I_n$
Repeatability	$\pm 1\%$

Operate Time	
Characteristics	DTL
No. of elements	2
Setting	Re-trip 0.00 to 20.00 sec Back-trip 0.00 to 20.00 sec
Accuracy	$\pm 5\text{ms}$
Repeatability	$\pm 1\%$ or $\pm 5\text{ms}$

Sample Specification

The feeder protection device shall integrate the following characteristics:

- Microprocessor device
- Current differential protection
- Guard relay
- Protection signalling supervision
- Backup overcurrent protection
- 1A and 5A current inputs on same device
- Trip circuit supervision
- Circuit breaker fail detection

Current Differential Protection

The current differential protection shall perform magnitude and phase angle comparison of currents, on a phase-by-phase basis, although tripping shall be three-phase.

The protection shall be capable of compensating for different CTs at each end of the feeder.

The protection shall be stable for through faults at high fault levels when the line CTs saturate.

Backup Overcurrent Protection

The backup three-phase overcurrent protection shall provide an IDMTL element and 3 DTL elements that will provide back-up protection for the event of a communications link failure.

Guard Relays

It will be possible to add an overcurrent guard to the differential protection to add security to the scheme.

Intertripping

The protection shall provide an intertrip facility capable of the following, as selected on the relay:

- a trip at the local end directly trips the circuit breaker at the remote end, or,

- a trip at the local end removes the need for a guard operation at the remote end, allowing tripping with a weak infeed.

Two additional intertrip channels shall be provided which allow external devices to directly trip remote

Testing

Testing facilities shall be provided that allow a single end to be tested in isolation, both ends to be tested together to ensure integrity of the communications link, and, both ends to be tested together to prove the directionality of the CTs

Signalling Channel

The protection shall use one of the following methods for signalling.

- RS485 electrical link using twisted-pair cable

- Optical-fibre link

- Electrical twisted pair using external modem

Continuous supervision of the protection signalling link shall be provided. The protection shall be capable of operating with propagation delays in the signalling channel varying up to 9.5ms.

Trip Circuit Supervision

The protection shall monitor the trip circuit when the circuit breaker is in both the open and closed position.

Circuit Breaker Fail

The protection shall provide have the ability to issue a backtrip in the event of circuit breaker failure, detected by the continued presence of current, rather than circuit breaker auxiliary switch position.

Indications

The protection shall provide indication of the following:

- Protection healthy

- Intertrip received

- Protection operating

- Trip

- Signalling channel healthy

Metering

The device shall be capable of displaying the following measurements without user intervention:

- Local and remote end primary currents

- Local and remote end secondary currents

- Differential primary currents

Disturbance Recorder

In the event of a trip the device shall record a disturbance record for a minimum of 1 second of the local and remote end currents, in primary amps.

Connection Diagram

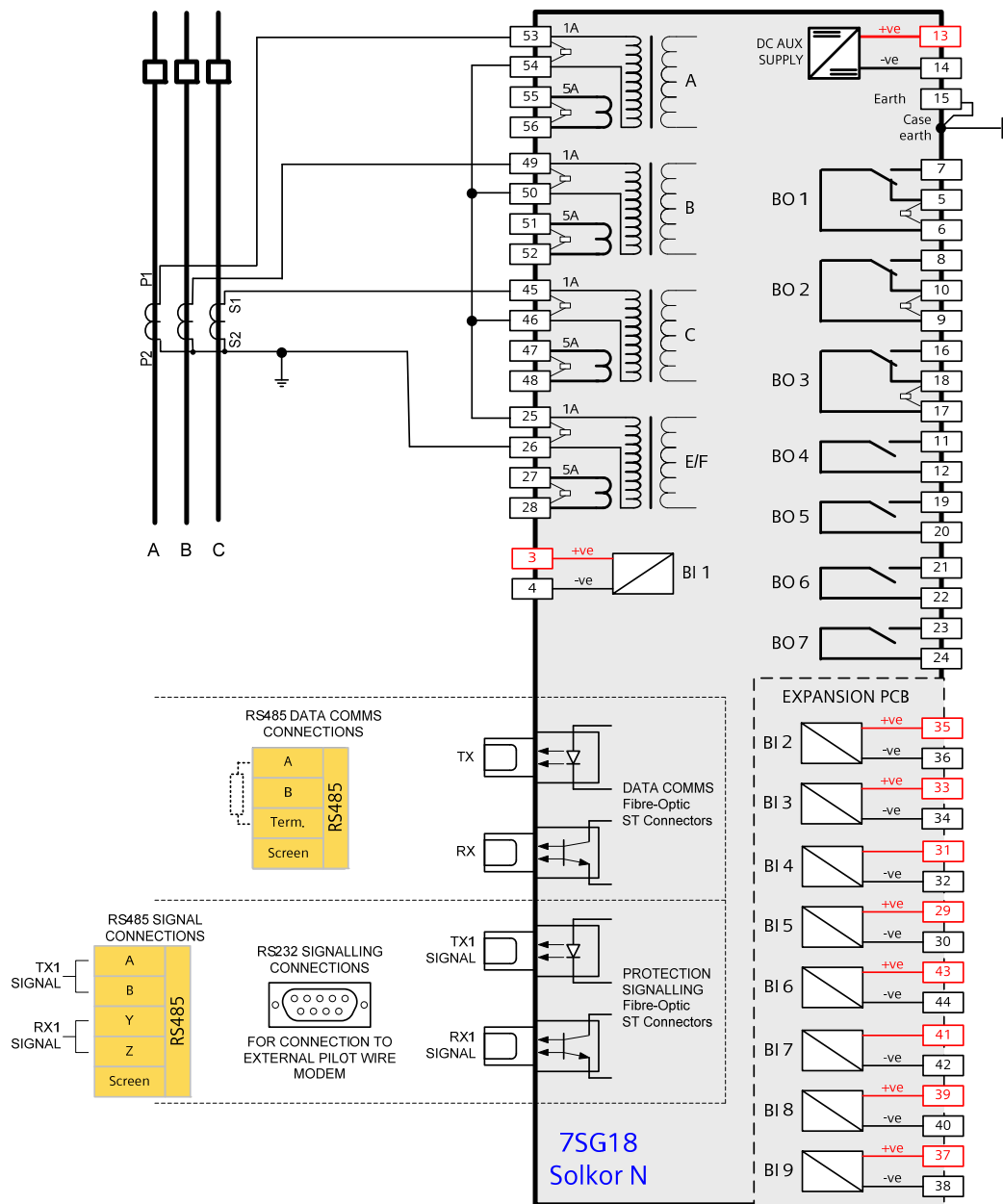

Notes

- 1) CT circuits are shown connected to relay 1A taps. Use alternative taps for 5A rated CTs.
- 2) CT and earth connections are typical only.
- 3) For terminal and comms options information see diagram below.

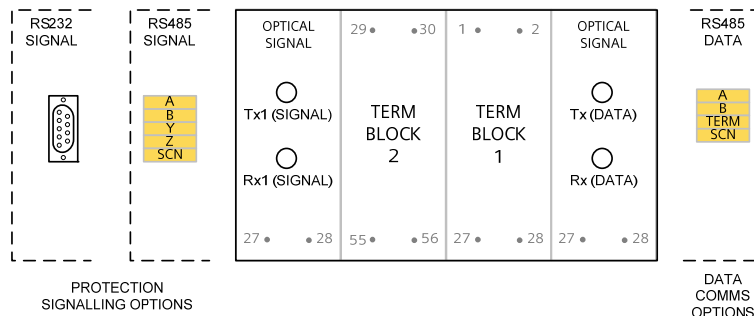
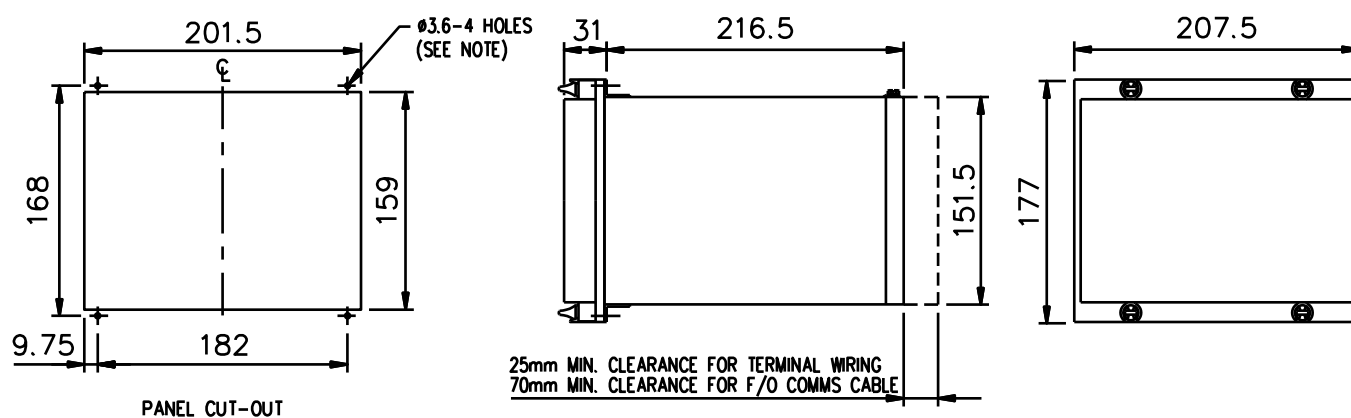

Fig 3. 7SG18 Connection Diagram

Case Dimensions



NOTE:
 THE Ø3.6 HOLES ARE FOR M4 THREAD FORMING (TRILOBULAR) SCREWS. THESE ARE SUPPLIED AS STANDARD AND ARE SUITABLE FOR USE IN FERROUS/ALUMINIUM PANELS 1.6mm THICK AND ABOVE. FOR OTHER PANELS, HOLES TO BE M4 CLEARANCE (TYPICALLY Ø4.5) AND RELAYS MOUNTED USING M4 MACHINE SCREWS, NUTS AND LOCKWASHERS (SUPPLIED IN PANEL FIXING KIT).

Fig 4. E8 Case

Ordering Information – 7SG18 Solkor-N

Product description	Variants	Order No.
---------------------	----------	-----------

Solkor-N

Line differential relay using direct fibre optic or metallic pilot wires for communication. Two terminal plain feeders only.

Relay type

Line differential

Protection options

Basic functionality

- 3-phase overcurrent (50/51)
- Earth-fault overcurrent (50N/51N)
- 3-Phase differential (with fixed settings) (87L)
- Trip circuit supervision (74TC)
- Circuit breaker fail (50BF)
- CT supervision
- External/Internal intertrip (96)

Basic functionality plus

- Variable differential settings

Protection signalling channel type

- RS485 electrical link (1200m)
- RS232 electrical to pilotwire link ²⁾
- 1300nm optical fibre link (0-16km) ³⁾
- 1300nm optical fibre link (49km) ³⁾

Auxiliary supply /binary input voltage

- 24/30/48 V DC auxiliary, 30 V DC/AC binary input
- 24/30/48 V DC auxiliary, 48 V DC/AC binary input
- 110/220 V DC auxiliary, 48 V DC/AC binary input ¹⁾
- 110/220 V DC auxiliary, 110 V DC/AC binary input
- 220 V DC auxiliary, 220 V DC/AC binary input

I/O range

- 1 Binary Inputs / 7 Binary Outputs (incl. 3 changeover)
- 9 Binary Inputs / 7 Binary Outputs (incl. 3 changeover)

Frequency

50Hz

Nominal current

1/ 5 A

Housing size

Case size E8 (4U high)

Communication interface

- Fibre optic (ST-connector) / IEC 60870-5-103 or Modbus RTU
- RS485 interface / IEC 60870-5-103 or Modbus RTU

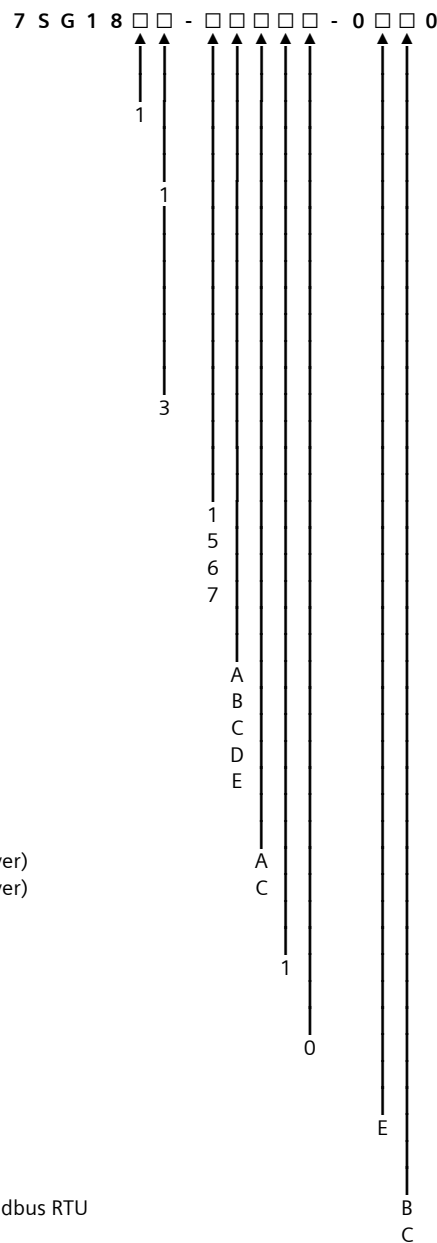

- ¹⁾ High burden 110V & 220V binary inputs compliant with ESI48-4 ESI 1 available via external dropper resistors with 48V binary input version
 - for 1 binary input and 110 V application, order resistor box VCE:2512H10066 in addition
 - for 9 binary inputs and 110 V application, order resistor box VCE:2512H10064 in addition
 - for 1 binary input and 220 V application, order resistor box VCE:2512H10068 in addition
 - for 9 binary inputs and 220 V application, order two resistor boxes 2512H10067 in addition
- ²⁾ Pilot wire modem (up to 10km) with RS232 interface in BOP mounting case is available for use with these models, order 7XG1210-1AA00-0AA0. Distance depends upon pilotwire parameters. Pilotwires must be screened twisted pair and two pairs are required for signalling
- ³⁾ Fibre Optic communication requires a compatible pair of relays at both ends. If ordering for one end only please specify details of the other end, which may need to be upgraded to be compatible to the new delivery. Upgrade kits available under VCE:2646G10014K (0-16km) and VCE:2646G10010K (49km).

Published by and copyright © 2010:
Siemens AG
Energy Sector
Freyeslebenstrasse 1
91058 Erlangen, Germany

Siemens Protection Devices Limited
P.O. Box 8
North Farm Road
Hebburn
Tyne & Wear
NE31 1TZ
United Kingdom
Phone: +44 (0)191 401 7901
Fax: +44 (0)191 401 5575
www.siemens.com/energy

For more information, please contact our
Customer Support Center.
Phone: +49 180/524 70 00
Fax: +49 180/524 24 71 (Charges depending on provider)
E-mail: support.energy@siemens.com

Power Distribution Division Order No. E53000-K7076-C32-1
Printed in Fürth

Printed on elementary chlorine-free bleached paper.

All rights reserved.

Trademarks mentioned in this document are the property of Siemens AG, its affiliates, or their respective owners.

Subject to change without prior notice.

The information in this document contains general descriptions of the technical options available, which may not apply in all cases. The required technical options should therefore be specified in the contract.