



Siemens Gas Turbine Package SGT5-PAC 4000F

Application Overview

Answers for energy.

SIEMENS



Siemens Gas Turbine Packages – Serving Your Project Needs

Siemens supplies standardized and pre-engineered gas turbine packages customized to match specific project needs in the form of simple cycle gas turbine power plants and combined cycle power plants.

The standard Siemens Gas Turbine Package (SGT-PAC) combines the essential mechanical, electrical, and control equipment to serve a variety of project scopes effectively. The SGT5-PAC 4000F is a key package for 50 Hz markets. The vital component is our advanced Siemens gas turbine SGT5-4000F.

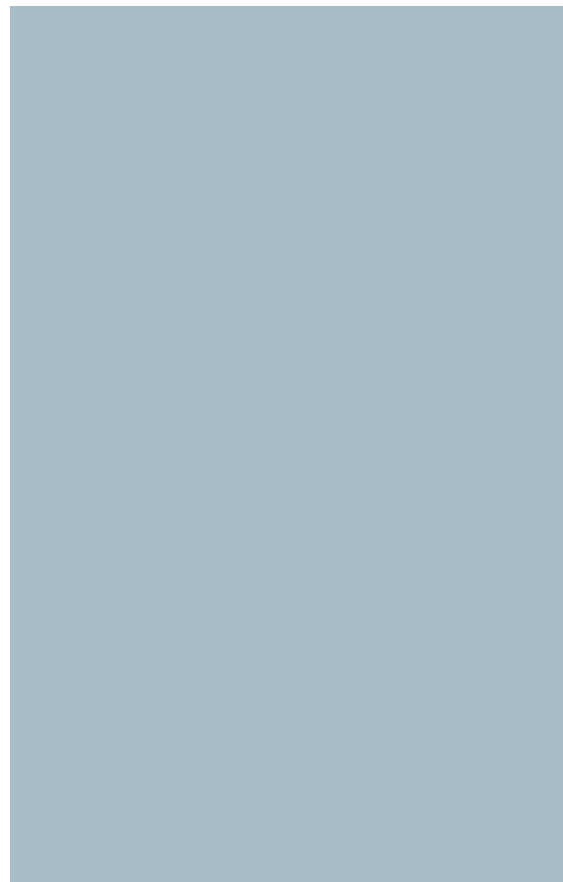

A Siemens Gas Turbine Package is:

- A cost-effective power generating system with pre-engineered and standardized design and base scope of supply, with interconnecting piping and wiring pre-assembled to a large degree.
- Flexible in design and scope thanks to pre-engineered options to meet project- and site-specific conditions, capable of increasing the operating flexibility and performance of an existing power generating system. These options can replace or add systems to the base scope.
- Focused on the core equipment of a self-contained power generating system for power plants with gas turbines, it consists of gas turbine and electrical

generator as well as all the systems required for the safe and reliable operation of these components: air intake system, exhaust gas system, electrical systems, instrumentation and control, generator excitation system, start-up system, and such major auxiliaries as the fuel system and lube oil system.

The development of this package stems from the requirements of the utility industry for low initial cost and a rapid and reliable on-line generation system. It is equally well-suited to meet the requirements of industrial users. Heat recovery applications include combined cycle, repowering, and cogeneration in a wide range of environments and requirements.

The SGT5-PAC 4000F is used for

- Generation of electrical power
- Combined heat and power
- Simple cycle gas turbine power plants
- Multi-shaft combined cycle power plants

operated in

- Base load service
- Intermediate load service
- Peak load service

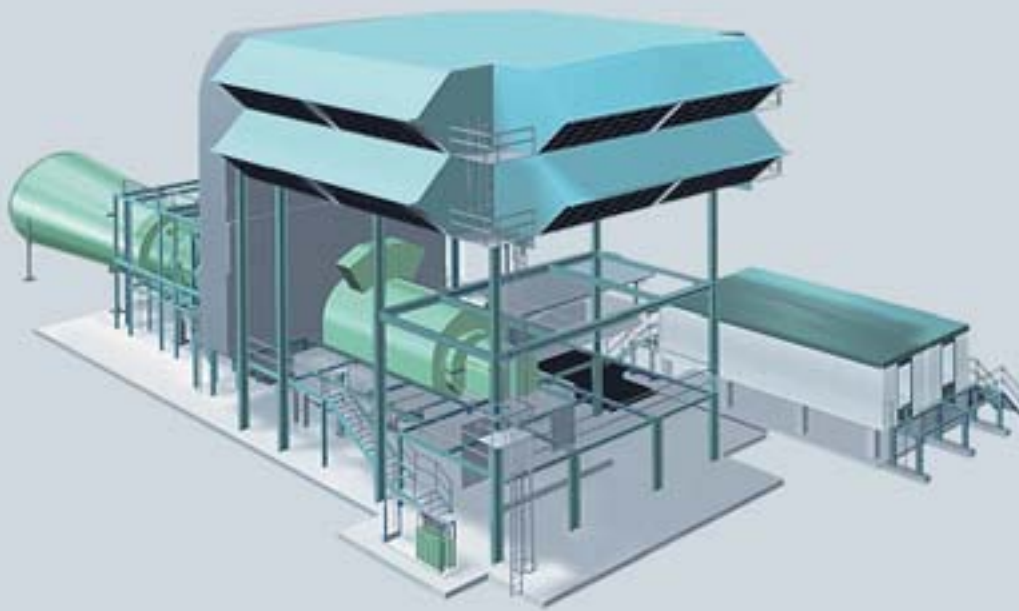

SGT5-PAC 4000F design with the filter-house in top position

Design Features and Arrangement

The design of the Siemens Gas Turbine Package represents over 50 years of experience in gas turbine technology and power plant design, resulting in a reliable self-contained electric power generating system.

The SGT5-PAC 4000F scope of supply represents the core equipment for a power plant equipped with gas turbines:

- Gas turbine
- Electrical generator
- Air intake system
- Exhaust gas system
- Start-up system
- Major auxiliary system
- Instrumentation and control
- Electrical systems
- Power control center
- Enclosures
- Fire protection
- Generator systems

To minimize field assembly and the need for piping fabrication during construction, Siemens utilizes a packaging and piping concept whenever possible. Moreover, subsystems have been grouped and installed in auxiliary packages.



Performance Data

Siemens SGT5-PAC 4000F Gas Turbine Package and Combined Cycle Plant

The performance data chart illustrates the application range of the Siemens SGT5-PAC 4000F Gas Turbine Package and the multi-shaft combined cycle plant as a typical application of the package.

	SGT5-PAC 4000F	SCC5-4000F 2x1 (multishaft)
Net power output (MW)	288	848
Net efficiency (%)	39.5	58.5
Net heat rate (kJ/kWh)	9,114	6,158
Net heat rate (Btu/kWh)	8,638	5,836
Exhaust temperature (°C/°F)	580/1,075	
Exhaust mass flow (kg/s)	688	
Exhaust mass flow (lb/s)	1,516	
Generator type	Air-cooled	

Data at ISO ambient conditions

Customer Benefits due to Extended Fleet Experience

A Siemens Gas Turbine Package is designed to meet customer requirements economically and flexibly. It is a cost-effective power generating system with standardized base design and base scope of supply with interconnecting piping largely pre-assembled.

Reliable project implementation with high product quality

through standardization of design with pre-defined interfaces to the overall power plant and use of proven components.

High reliability

through robust component and system designs and implementation of large fleet operating experience (total gas turbine fleet experience: > 1,240 units, > 220 GW, > 28 Million operating hours).

High availability

through service-friendly components and optional diagnostic service.

Fuel cost savings

through high component efficiencies and short start-up times.

Environmental friendliness

through low emissions and high efficiencies.

High operating flexibility

through use of online-change to different fuels and through excellent start-up and part load operating capabilities.

Flexibility to match customer- and site-specific needs

through pre-defined options that can be changed or added to the base scope.

Fast construction times

through shipment of pre-assembled system to site.

Compact plant size

through small-footprint arrangement of systems.

World-wide experience

The SGT5-4000F has been in service since 1997. Over 190 engines of this advanced gas turbine family are in operation, and over 65 are on order. More than 4,727,000 (as of Aug 2009) cumulative operating hours and a fleet reliability exceeding 99 % have been achieved.

Siemens Simple Cycle Applications

The SGT5-PAC 4000F is a self-contained electric power generating system suitable for simple cycle base load, intermediate load and peaking applications. Features proven in previous designs have been incorporated into the SSC5-4000F power plant. These include

- Factory assembled fuel, auxiliary, mechanical, and electrical packages
- Enclosures for turbine and auxiliary packages
- A microprocessor-based control system
- A starting frequency converter system

Siemens Combined Cycle Applications

Siemens has more than three decades of experience in combined cycle plant design. That is why Siemens Combined Cycle Plants (SCC) affiliates the economical benefits of a pre-engineered power plant design with outstanding flexibility through a wide range of options. Single as well as multi-shaft configurations are available.

The current SCC5-4000F Siemens Combined Cycle Plants incorporate the vast expertise and experience gained from many previous design accomplishments. The SCC5-4000F family is dimensioned to meet the various base and cycle load requirements of utilities, independent power producers, industrial users, and merchant plant operators. The development of these designs allows for cost-effective plants with minimum project-specific engineering.



Typical plant layout for single-unit gas turbine package

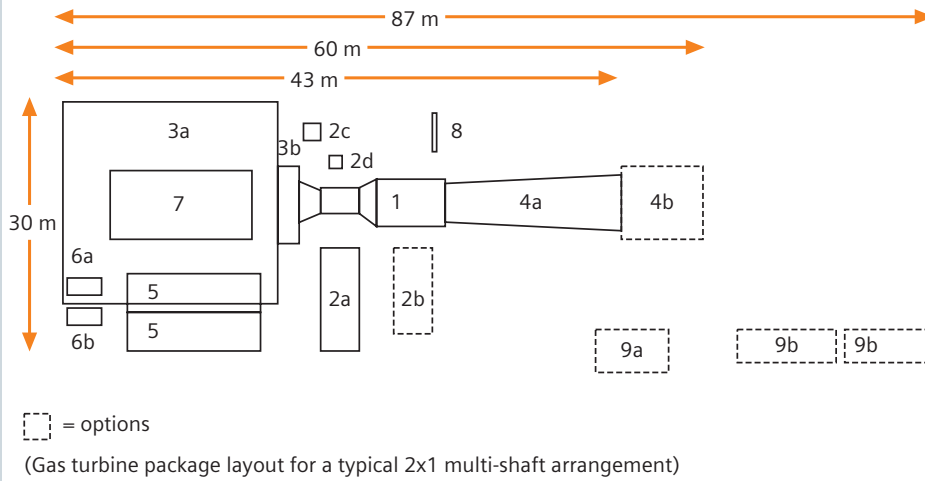

- 1 Gas Turbine
- 2a Auxiliary Systems Module for Fuel Gas, Hydraulic Oil, Instrument Air, Lube Oil
- 2b Auxiliary Systems Module for Fuel Oil, Purge Water, NO_x Water
- 2c Compressor Cleaning Skid
- 2d Compressor Dehumidifier Skid
- 3a Air Intake Filter House (envelope is shown schematically)
- 3b Air Intake Duct
- 4a Exhaust Gas Diffuser
- 4b Stack or Bypass Stack with Diverter Damper
- 5 Power Control Center with Electrical and I&C Equipment
- 6a Low Voltage Transformer for Static Excitation Equipment
- 6b Low Voltage Transformer for Starting Frequency Converter
- 7 Electrical Generator
- 8 CO₂ Fire Protection
- 9a Lube Oil Fin-Fan Cooler
- 9b Generator Fin-Fan Cooler

Plant Arrangement Diagram

Plant arrangements and systems configuration are illustrated in the chart above.

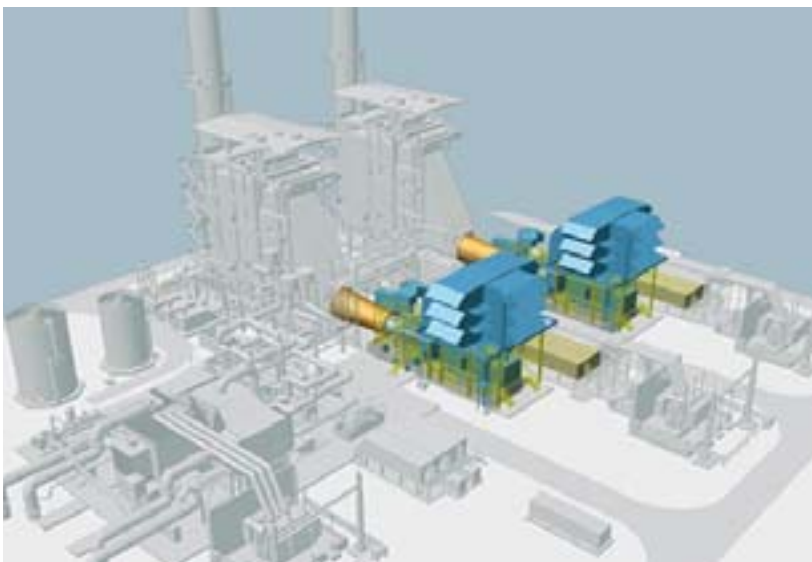

Siemens Gas Turbine Package SGT5-PAC 4000F in a multi-shaft combined cycle power plant

SGT5-4000F Gas Turbine

Compressor

Type	Disk-type hollow shaft
Number of Stages	15
Rotor Speed	3,000 rpm
Pressure Ratio	18:1
Inlet Guide Vanes	One row variable

Combustion System

Combustors

Type	1 ring combustor system
Configuration	Annular
Fuel	Gaseous and liquid
Number	24

Fuel Pressure Range

Natural Gas	27 bar–33 bar; Nominal @ gas turbine; Filter inlet flange
-------------	--

Turbine

Number of Stages	4
Number of Cooled Stages	3

Bearings

Journal Bearing

Type	Tilting pad
Quantity	1

Thrust Bearing

Number	1
--------	---

Drive

Generator coupled to cold end of turbine via intermediate shaft

SGen5-1000A Generator

Generator rating @ 40°C air inlet temperature, TEWAC

kVA	334,000
kW	283,900
P.F.	0.85
Voltage (Volts) line-to-line	20,000
Calculated short circuit ratio	0.49
Speed (rpm)	3,000
Frequency (Hz)	50
Line current (Amps)	9,641
Altitude (meters)	Sea level

Insulation

Class of insulation	Stator-class – F with class B temperature rise Field-class – F with class B temperature rise
---------------------	---

Technical Data

In the following table data are provided for planning purposes.

Weights and Dimensions					
Shown below is a typical list of the major pieces of equipment along with their approximate nominal shipping weights and nominal dimensions					
Item	Length	Width	Height	Weight	Remarks
Gas Turbine					
SGT5-PAC 4000F Gas Turbine	10.8 m	5.2 m	4.8 m	312,000 kg	
Auxiliary Systems					
Module for Fuel Gas Operation	11.5 m	3.3 m	3.8 m	20,000 kg	
Module for Fuel Oil Operation	9.5 m	3.3 m	3.2 m	24,000 kg	
Compressor Cleaning System					
Base Version	1.9 m	1.1 m	1.6 m	850 kg	
Advanced Cleaning System	2.7 m	2.0 m	2.2 m	1,500 kg	
Air Intake System					
Filterhouse	14 m	18 m	11 m	120,000 kg	
Silencer	*	9.5 m	7 m	*	
Duct	9.5 m	2.2 m	18 m	50,000 kg	
Generator					
SGen5-1000A Generator					
Assembled (with enclosure)	14.11 m	8.63 m	5.94 m	359,000 kg	
Shipping	13 m	4.6 m	4.4 m	318,000 kg	
Power Control Center	12.28 m	3.64 m	3.33 m	22,000 kg	

(* = project-specific)

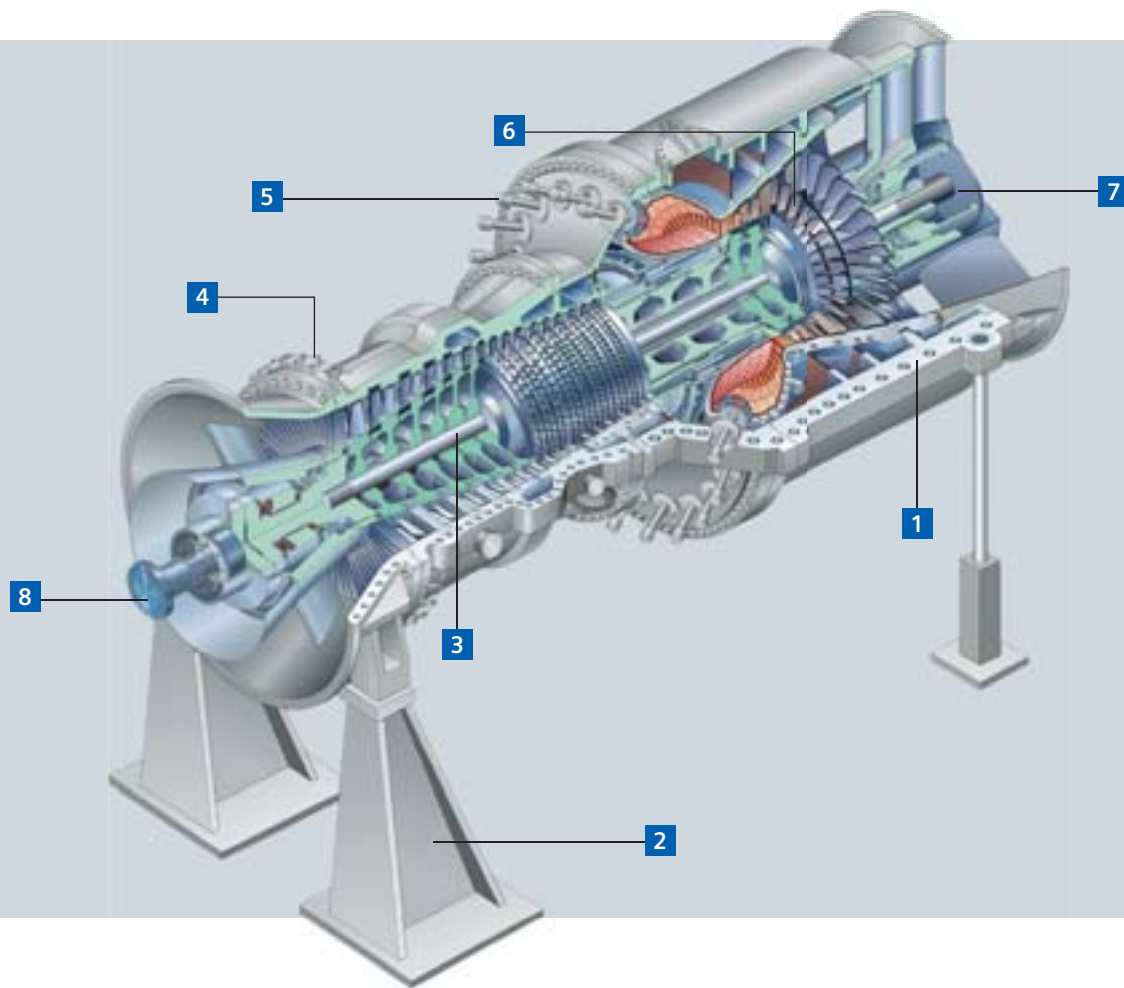

SGT5-4000F

1 Casing

- Horizontally split

2 Supports

- Fixed at compressor end
- Flexible at turbine end

3 Rotor

- Disk-type hollow shaft
- Combined thrust and journal bearing at compressor end
- Journal bearing at turbine end
- Compressor and turbine disks interlocked via Hirth serrations
- Compressor and turbine disks axially fixed via one central tie bolt

4 Compressor

- 15-Stage axial
- Variable-pitch inlet guide vanes

5 Combustion

- Annular chamber with ceramic and metallic heat shields
- 24 hybrid burners
- Dry low-NO_x technology
- Operation with gaseous and liquid fuels

6 Turbine

- 4-Stage
- Thermal barrier blade coatings
- Convection and impingement cooling of blade interior
- Film cooling of blade airfoil surface

7 Exhaust

- Axial flow

8 Generator coupling

- At cold end drive





Auxiliary Systems

Fuel

- Gas fuel system supplies gaseous fuel with adequate mass flow to the gas turbine.
- Fuel oil system as an option supplies liquid fuel with adequate mass flow to the gas turbine.
- Optionally, a dual-fuel system provides highest fuel flexibility.

Rotor turning

- Turning device – the gas turbine rotor is rotated at low speed, for start-up, shutdown, and extended standstills.

Hydraulic Clearance Optimization

- The HCO (Hydraulic Clearance Optimization) power unit, supplies hydraulic oil for shifting the gas turbine rotor into the best-performance position with minimized clearances on the turbine side.

Cleaning

- A mobile compressor cleaning system supplies water for the compressor wash procedure to maintain high compressor efficiency.

Start-up

- Starting frequency converter (SFC) for static start-up.

Valve actuation

- A hydraulic oil system provides high-pressure hydraulic oil to operate the control and emergency stop valves of the fuel systems and NO_x water system.
- Instrument air system for the supply of compressed air to operate the pneumatic actuators (e.g., blow-off valves).

Lubrication

- Lube oil system – supplies lubrication oil to the gas turbine, the generator, and the HCO power unit and supplies lifting oil to the gas turbine, the generator, and the hydraulic-type rotor turning device.

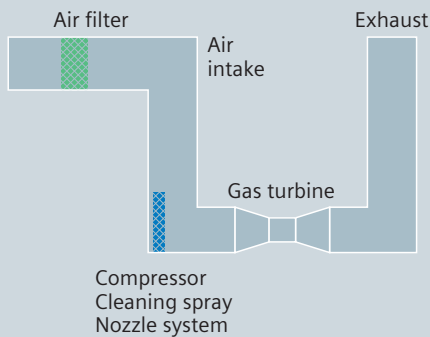

Filter system

- **Two-stage** static filter
- **Self-cleaning** pulse filter (optional)

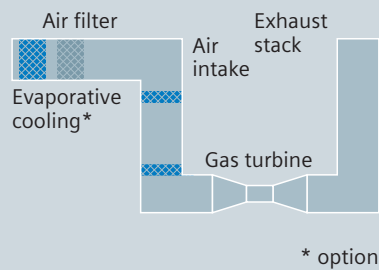

* option

Inlet air cooling

Inlet air cooling provides more power when needed:

- under hot and dry ambient conditions
- at times of high power demand

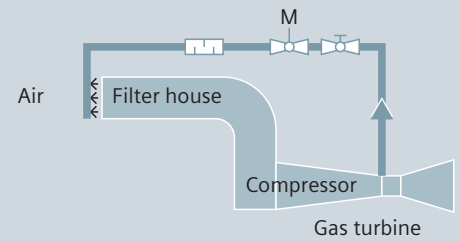

Air anti-icing

The anti-icing system avoids ice effects under very cold ambient conditions and thus avoids pressure losses

Air Intake System

Functions

- Guiding and filtering of ambient air to the gas turbine for reliable operation
- Reducing noise from the gas turbine compressor to permissible levels

System scope

- Filter house with filter system
- Air intake duct with silencer

Design

- Top inlet air intake: the filter house is located above the generator and inlet duct and extends vertically to the gas turbine
- House configuration: the support structure is supplied with existing building structure (civil scope)
- Compressor cleaning spray nozzle system
- Filter Systems: static filter as standard, pulse filter as an option
- Anti-icing system can be provided
- Inlet air cooling systems on request





Exhaust Gas System

Functions – Exhaust system

- The system guides exhaust gas from the gas turbine via the diffuser to the stack of a gas turbine plant, or to the heat recovery steam generator of a combined cycle plant. Gas turbine availability can be increased with a diverter and bypass stack for combined-cycle power plants.
- At the same time, the system reduces noise from the gas turbine to permissible levels.

System scope

- Exhaust diffuser
- Exhaust stack for simple cycle plants as an option for simple cycle applications
- Diverter damper with bypass stack for combined cycle plants as an option for combined cycle applications

Enclosures

Functions

Indoor enclosures:

- Optimum noise protection at indoor installation in the turbine building
- Delineation of hazardous areas
- Containment of fire suppression agent

Weather enclosures are available on request:

Noise and weather protection for outdoor installation

System scope

Enclosures when applicable with:

- Ventilation system
- Fire detection system
- Fire fighting system
- Gas detection system

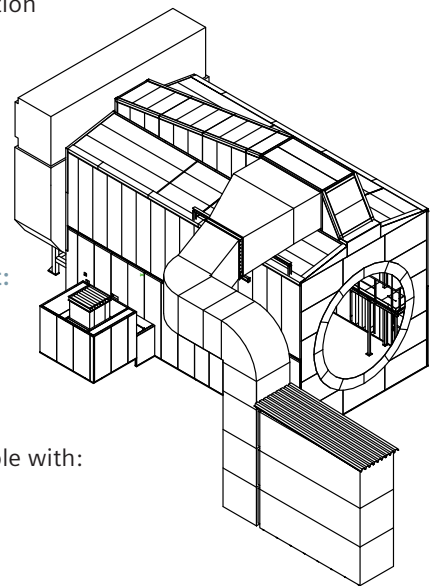



SPPA-T3000 Control System

Electrical and Control System

Functions – Electrical system

- Energy supply for package equipment
- Generator protection, excitation, and static start-up equipment

System scope

- AC/DC low-voltage switchgear and motor control centers for gas turbine consumers
- Uninterruptable power supplies (batteries, chargers, DC/DC-converters) for gasturbine consumers
- Generator protection, synchronization equipment, measurement of electrical values
- Power control center (standard) to accommodate the electrical and instrumentation and control equipment

- Static excitation system for the electrical generator
- Starting frequency converter for gas turbine start-up
- Low voltage transformers for the static excitation equipment and starting the frequency converter

Functions – SPPA-T3000 Control system

- Open loop control: step sequences for start-up and shutdown, drive control
- Closed loop control: fuel valves, compressor
- Inlet guide vane variation
- Protection: engine protection, failsafe protection circuits
- Operation and monitoring: human-machine-interface

System scope and functions

- Operating and monitoring of the plant
- Automation (basic automation, turbine control, failsafe protection)
- Engineering of the instrumentation and control system
- Diagnostics on the instrumentation and control system
- Diagnostics on the package
- Bus systems

Benefits

- Single user interface for all functions, from anywhere
- Intuitive links throughout the entire system
- Speeds up the work-flow



Power Control Center



Features of the Power Control Center

The features of the Power Control Center (PCC) modules make them equivalent to a conventional housing/building:

- The degree of protection of the switchgear rooms is IP 54.
- The switchgear room temperature in the PCC modules is controlled between 10 °C and 35 °C by air-conditioning units. At least one redundant air-conditioning aggregate is provided.
- The air is cleaned by a filter. The sealed construction prevents any ingress of moisture or dust by leakage. In addition, the heat exchangers dehydrate the replacement air so that condensation inside the modules cannot occur.



SGen5-1000A

One generator assembly consisting of the following components is delivered to the site:

- Bedplate
- Spring mounted stator
- Bearing pedestals
- Rotor with shrunk-on collector
- Stator inner enclosure

At the site, an outer enclosure is erected around the generator that includes coolers, current transformers, and neutral grounding equipment.

The SGen5-1000A air-cooled generator features:

- 165 – 350 MVA range (at 40 °C cold gas condition)
- World class efficiency with low maintenance design
- Multi-zone, indirectly cooled stator windings
- Roebell stator windings with brazed solid end connections
- Radially ventilated stator core attached to bedplate
- Global Vacuum Pressure Impregnated (GVPI) stator core and stator winding
- Core suspended on two axial springs
- Radially ventilated and cooled rotor winding
- Two low pressure “push” fans mounted at each end of the rotor
- Weather and sound proof outer generator enclosure
- Coolers mounted on foundation beside bedplate and inside outer enclosure for a TEWAC (Totally Enclosed Water to Air-cooled) generator

Overhung collector and brush holders bedplate

The stator bedplate is a heavy steel fabrication, which supports the stator core and windings, bearing pedestals, rotor assembly excitation casing, and the inner enclosure. The bedplate rests on leveling devices (fixators) affixed to the foundation and is secured with foundation bolts and axial and transverse anchors. Features for lifting and suitable jacking points for alignment to the turbine are also provided.



Power Diagnostics

Power Diagnostics® Services

Remote online monitoring of entire power plants or vital power plant components via Siemens Power Diagnostics Services is a key to mitigate risk for long-term service contracts. Based on several Power Diagnostics Centers worldwide Siemens provides the Service of daily Online Remote Diagnostics exclusively for Customers with long-term service agreements. Currently more than 300 advanced frame gas turbines, as well as heat recovery boilers, steam turbines and generators are monitored via those centers by Siemens experts to ensure the most trouble-free operation.

The WIN_TS diagnostic system including a broadband connection for unlimited remote access has to be installed for online remote diagnostic services. The connection of a phone line exclusively assigned for the use of WIN_TS or an internet link is required as a contractual obligation of the customer already before commissioning starts.

Benefits

During plant operation, online remote diagnostics provide the following advantages:

- Plants can be monitored effectively by Power Diagnostics Centers and OEM experts, e.g., of forced outages or emerging damages by detection of possible engine failures before they occur can be avoided
- Risk mitigation through service support for O&M and LTP during gas turbine life cycle, e.g., condition based outage planning by Siemens with the strong support of Siemens experts from all disciplines
- Detailed information on plant's history, long term trends, and optimization of operational reliability and availability

It also supports

- OEM's engineering staff in developing their modernization and upgrade programs as well as Performance Enhancement Programs and optimization of Operational Reliability and Availability Programs

Your benefits include:

- Improved performance in terms of availability, reliability, efficiency and flexibility
- Reduced maintenance costs by extended maintenance intervals, condition based maintenance and shorter outages

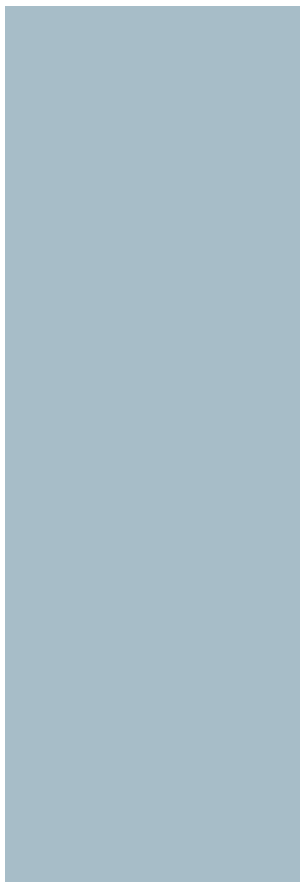

Service and Support

Corrective & preventive maintenance
Expecting a reliable high output from your plant, we set the goal to help you cut downtimes to a minimum. With our diagnostic services we can even identify faults before they become failures. From installation and commissioning, scheduled overhauls, on-site/factory repairs to spare parts, we are ready to serve you. With our remote monitoring & diagnostics capabilities we can help you instantly. Our global team of more than 3,000 highly qualified Siemens service specialists is dedicated to providing sound, reliable and continuing support. Anywhere, any time.

Service agreements
To plan well ahead a service agreement for your plant can best support your long-term goals. We can help proactively boost your plant's performance through various service options. From operating plant service agreements to full-scope operation, maintenance contracts and remote monitoring – Siemens Energy's service solutions can be adapted to your exact needs: scheduled inspections, preventive maintenance, remote monitoring, replacement parts programs and incentives. In addition, we offer on-site operation & maintenance contracts for power plants.

- Benefits include:
- Optimized return on investment
 - Optimized performance
 - Optimized strategic planning for operating assets
 - Reduced maintenance costs

Training & Consulting Siemens Power Academy (SPA)
Training courses and programs designed to provide you essential knowledge of equipment and systems ensure your safe, reliable operation and routine maintenance for your assets.



SGT5-4000F Steam Production

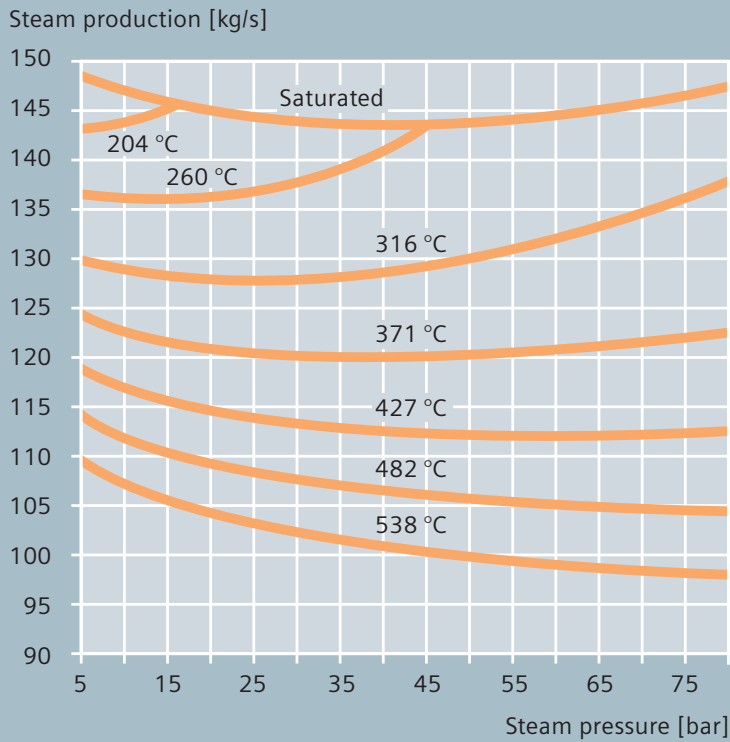

Cogeneration or Combined Heat and Power

General description

Owners and operators of industrial and commercial facilities are actively looking for ways to use energy more efficiently. One option is cogeneration, also known as combined heat and power (CHP). Cogeneration/CHP consists of simultaneous production of electricity and useful heat from the same fuel or energy. The owner of a SGT5-PAC 4000F cogen system can use it to produce their own electricity, produce electricity for sale to others, or use the excess (waste) heat for process steam, hot water heating, space heating and other thermal needs.

The excess heat also can be used to produce steam that can drive a steam turbine-generator to produce additional electricity. A SGT5-PAC 4000F-based cogen system can be designed, with the addition of the appropriate heat recovery boiler

and steam turbine-generator, to use the maximum amount of available energy. The steam turbine can be selected from extraction, condensing or backpressure styles to best match the customer's process steam and electricity requirements.

Steam production calculation

The figure above shows the typical steam production capability of the SGT5-PAC 4000F for a range of steam pressures and temperatures.

- The referenced results are for
- Base load operation at sea level,
 - 15 °C compressor inlet temperature,
 - 60 % relative humidity of the air and
 - Natural gas fuel.

The heat recovery system chosen has one pressure level, a 8.3 K pinch point, 5.5 K approach temperature and no supplementary firing. Although steam production varies depending on site conditions and gas turbine loading, the figure provides an estimate of what can be achieved with a SGT5-PAC 4000F.

References



Hamm-Uentrop, Germany

Trianel Power Kraftwerk Hamm-Uentrop GmbH & Co. KG operates the combined cycle power plant with a total capacity of 850 MW. Included in the scope are two gas turbine packages SGT5-PAC 4000F.



Al Taweelah, United Arab Emirates

Al Taweelah A2 is the first IPP project in the Middle East. The project with an output of 780 MW represents the first combination of a combined cycle power plant with a desalination plant. The scope included three gas turbine packages SGT5-PAC 4000F and two steam turbines.



Panglima, Malaysia

Panglima Power Sdn Bhd operates the combined cycle power plant with a multi-shaft 2 x 1 unit that has a total capacity of 780 MW, including two gas turbine packages SGT5-PAC 4000F.



Antalya, Turkey

The Ali Metin Kazanci Power Plant in Antalya, Turkey consists of two gas turbine packages SGT5-PAC 4000F. The power plant is built and operated by the Turkish company AKSA and covers a major part of the high energy demand in Antalya – one of the major tourist areas in Turkey. The 520 MW Open Cycle plant was built by AKSA in world record time. In a second phase this plant will be completed by AKSA to an 780 MW Combined Cycle Power Plant with one Siemens Steam Turbine Package SST-5000.

Published by and copyright © 2009:
Siemens AG
Energy Sector
Freyeslebenstrasse 1
91058 Erlangen, Germany

Siemens Energy, Inc.
4400 Alafaya Trail
Orlando, FL 32826-2399, USA

For more information, please contact
our Customer Support Center.
Phone: +49 180/524 70 00
Fax: +49 180/524 24 71
(Charges depending on provider)
E-mail: support.energy@siemens.com

Fossil Power Generation Division
Order No. E50001-G210-A130-X-4A00
Printed in Germany
Dispo 34802, c4bs No. 7813, 7448, 7449
TH 214-090649 430173 WS 09092.0

Printed on elementary chlorine-free bleached paper.

All rights reserved.
Trademarks mentioned in this document
are the property of Siemens AG, its affiliates,
or their respective owners.

Subject to change without prior notice.
The information in this document contains general
descriptions of the technical options available, which
may not apply in all cases. The required technical
options should therefore be specified in the contract.