

The image shows a large industrial facility, likely a power plant or substation, with rows of complex electrical equipment. The equipment consists of metal frames with multiple levels of busbars and insulators. In the foreground, there are large, cylindrical components with a ribbed texture, possibly part of a reactor or transformer. The background shows a long aisle with more equipment stretching into the distance. The overall scene is brightly lit, suggesting an indoor industrial environment.

SIEMENS

www.siemens.com/energy/facts

Discover the World of FACTS Technology

Technical Compendium

Answers for energy.

Contents

Chapter	Theme	Page
1	Facts on FACTS – Theory and Applications	3
1.1	FACTS – What and why?	3
1.2	FACTS for supplying power – Now and in the future	3
1.3	Tasks of FACTS devices	3
2	Basics	4
2.1	Reactive power compensation	4
3	Parallel and Series	5
4	Parallel Compensation	6
4.1	Technology, theory, and basics	6
4.2	Mechanically switched compensation devices	7
4.3	SVC – Static VAR Compensator	8
4.4	SVC PLUS (STATCOM)	16
5	Series Compensation	17
5.1	Technology, theory, and basics	17
5.2	Types	17
5.3	Layout	20
6	Protection and Control	21
6.1	Hardware for control and protection	21
6.2	Human Machine Interface	21
7	Converters for FACTS	22
7.1	LTT – Light Triggered Thyristors	22
8	Complete Solutions	23

1 Facts on FACTS – Theory and Applications

1.1 FACTS – What and why?

FACTS is the acronym for Flexible AC Transmission Systems and refers to a group of resources used to overcome certain limitations in the static and dynamic transmission capacity of electrical networks.

The IEEE defines FACTS as “alternating current transmission systems incorporating power-electronics-based and other static controllers to enhance controllability and power transfer capability.”

The main purpose of these systems is to supply the network as quickly as possible with inductive or capacitive reactive power that is adapted to its particular requirements, while also improving transmission quality and the efficiency of the power transmission system.

1.2 FACTS for supplying power – Now and in the future

The inevitable globalization and liberalization of energy markets associated with growing deregulation and privatization are increasingly resulting in bottlenecks, uncontrolled load flows, instabilities, and even power transmission failures. Power supplies are increasingly dependent on distributed power plants with higher voltage levels, a greater exchange within meshed systems, and transport to large load centers over what are often long distances. This type of power transmission must be implemented safely and cost-effectively with a view to the future.

Implementing new transmission systems and components is a long-term strategy for meeting these challenges. Over the short and medium term, modern transmission technologies can be employed at comparatively little expense to rectify or minimize bottlenecks and substantially improve the quality of supply. Often, this makes it possible to postpone investing in new plants and, as a result, to achieve critical advantages over the competition – especially important in de-regulated energy markets in which power supply companies are subject to extreme pricing pressure.

As a world leader in the power transmission and distribution industry, Siemens has developed a number of modern, flexible, high-capacity FACTS for efficiently and reliably regulating voltage, impedance, and phase angle when transmitting power over high-voltage lines.

FACTS provide

- fast voltage regulation,
- increased power transfer over long AC lines,
- damping of active power oscillations, and
- load flow control in meshed systems, thereby significantly improving the stability and performance of existing and future transmission systems.

This means that with FACTS, power companies will be able to better utilize their existing transmission networks, substantially increase the availability and reliability of their line networks, and improve both dynamic and transient network stability while ensuring a better quality of supply.

1.3 Tasks of FACTS devices

FACTS systems perform the following tasks:

- Control voltage under various load conditions
- Balance reactive power (voltage, transmission losses)
- Increase the stability of power transmission over long distances
- Increase active power stability

2 Basics

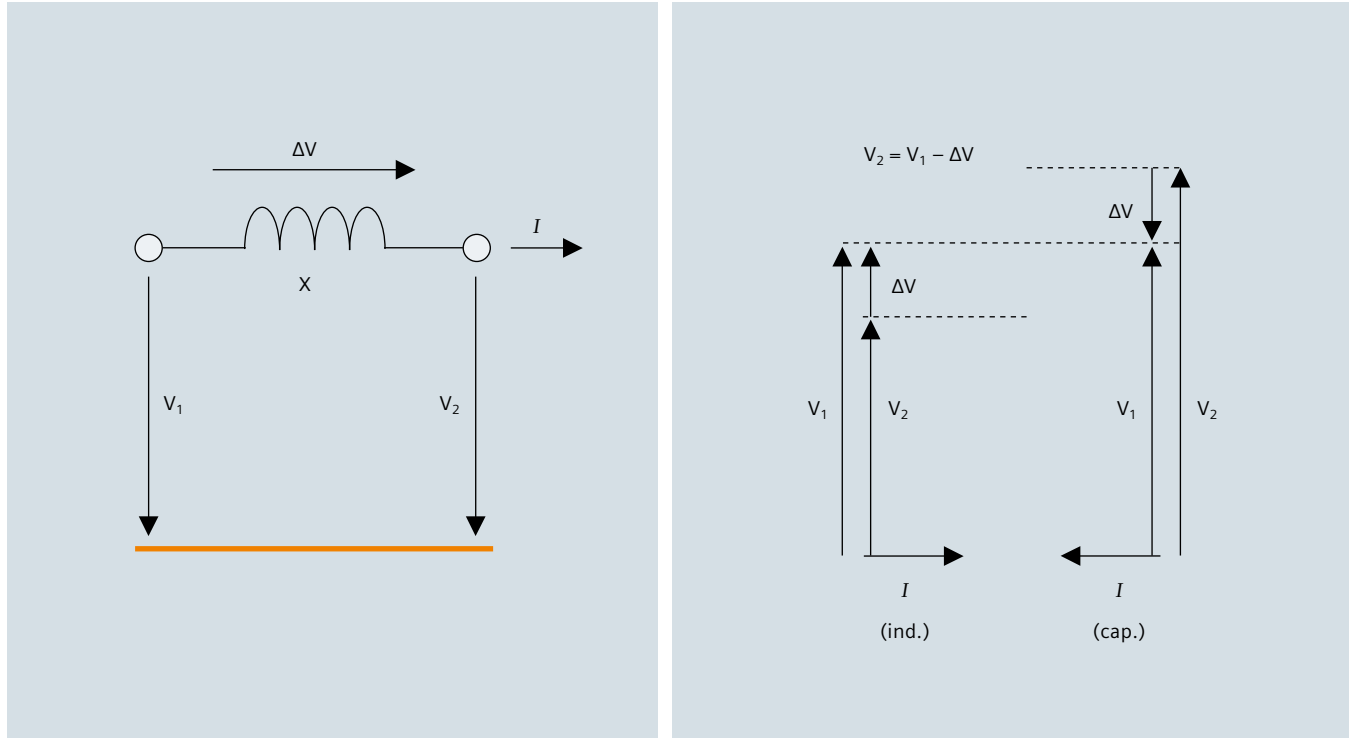

Fig. 2.1: Influence of reactive power flow on system voltage

2.1 Reactive power compensation

Consumer load requires reactive power that varies continuously and increases transmission losses while affecting voltage in the transmission network. To prevent unacceptably high voltage fluctuations or the power failures that can result, this reactive power must be compensated and kept in balance.

This function has always been performed by passive elements such as reactors or capacitors, as well as combinations of the two, that supply inductive or capacitive reactive power.

The more quickly and precisely the reactive power compensation can be accomplished, the more efficiently the various transmission characteristics can be controlled. For this reason, slow mechanically switched components have been almost completely replaced by fast thyristor-switched and thyristor-controlled components.

2.1.1 Effects of reactive power flow

Reactive power flow has the following effects:

- Increase in transmission system losses
 - Adding to power plant installations
 - Adding to operating costs
- Major influence on system voltage deviation
 - Degradation of load performance at undervoltage
 - Risk of insulation breakdown at overvoltage
- Limitation of power transfer
- Steady-state and dynamic stability limits

3 Parallel and Series

Type	Short-circuit level	Transmission phase angle	Steady-state voltage	Voltage after load rejection	Application
 MSC	nearly unchanged	slightly increased	increased	high	voltage stabilization at heavy load
 MSR	nearly unchanged	slightly increased	decreased	low	voltage stabilization at light load
 Static VAR compensator	nearly unchanged	controlled	controlled	limited by control	fast voltage control reactive power control damping of power swings

Fig. 3.1 shows today's most common shunt compensation devices, their influence on the most important transmission parameters, and typical applications

FACTS are divided into two categories, determined by the way in which they are connected to the power system.

A distinction is made between parallel compensation (which continues to be the most common) and series compensation (Fig. 3.2).

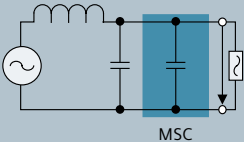
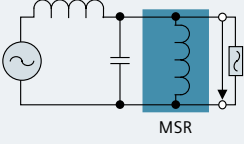
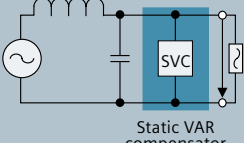
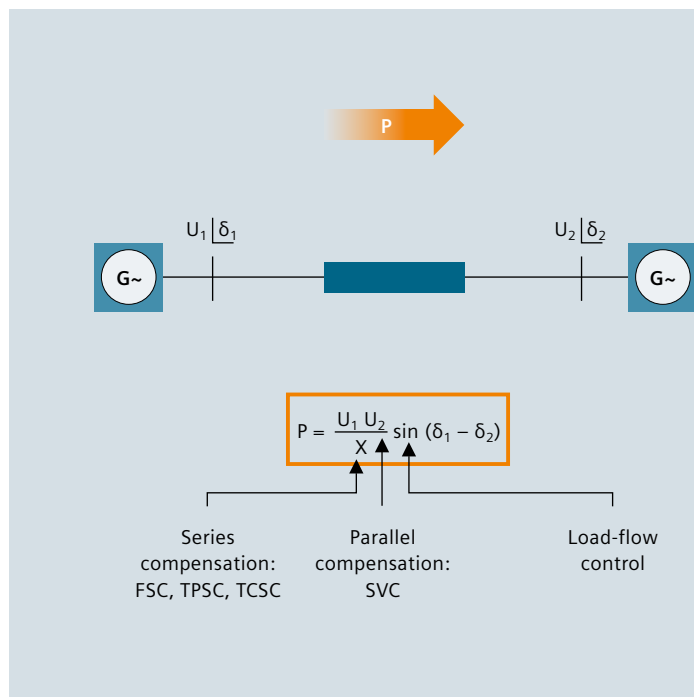

Fig. 3.2: The active power/ transmission angle equation illustrates which FACTS components selectively influence which transmission parameters

4 Parallel Compensation

4.1 Technology, theory, and basics

Parallel (between a bus bar and ground) reactive power compensation can be used to selectively influence important transmission parameters. Parallel capacitor banks support the voltage under heavy load conditions. This protection can increase maximum transmittable power, regulate the voltage profile, and prevent voltage instability. Parallel reactors prevent overvoltages under low load conditions. The key components of a parallel reactive power compensation system are thyristor-switched capacitors (TSCs) and thyristor-controlled reactors (TCRs), which can be supplemented with filter branches as needed.

4.1.1 Harmonics

Harmonics are whole multiples of the fundamental frequency (50 Hz/60 Hz) that are superimposed on it. Harmonics cause the system voltage to deviate periodically from the sinusoidal shape, resulting in voltage distortion. Harmonics are caused by devices with non-sinusoidal power input, including power converters, frequency converters, rectifiers and TCRs. A high harmonic content in the voltage of an electrical network can result in an unacceptable temperature rise in electric machines and a voltage increase in capacitor banks.

The 5th, 7th, 11th, and 13th harmonics are characteristic of TCRs and are especially dominant, but maximum magnitudes decrease very fast with increasing harmonic numbers. The occurrence and effect of the intermediate, noncharacteristic harmonics, in contrast, are much less pronounced. The magnitude and the occurrence of harmonics in a TCR branch are given in Fig. 4.1.

4.1.2 Filter branches

Filters serve to absorb harmonics. The number of filter branches and their resonance tuning frequency depend on the basic design of the Static VAR Compensator (SVC) and the harmonic distortions in the system. Filters can be tuned either to a single frequency or to multiple frequencies simultaneously. High-pass and low-pass filters can also be used. Filters are connected to the bus bar via circuit-breakers to absorb their harmonics where they are generated.

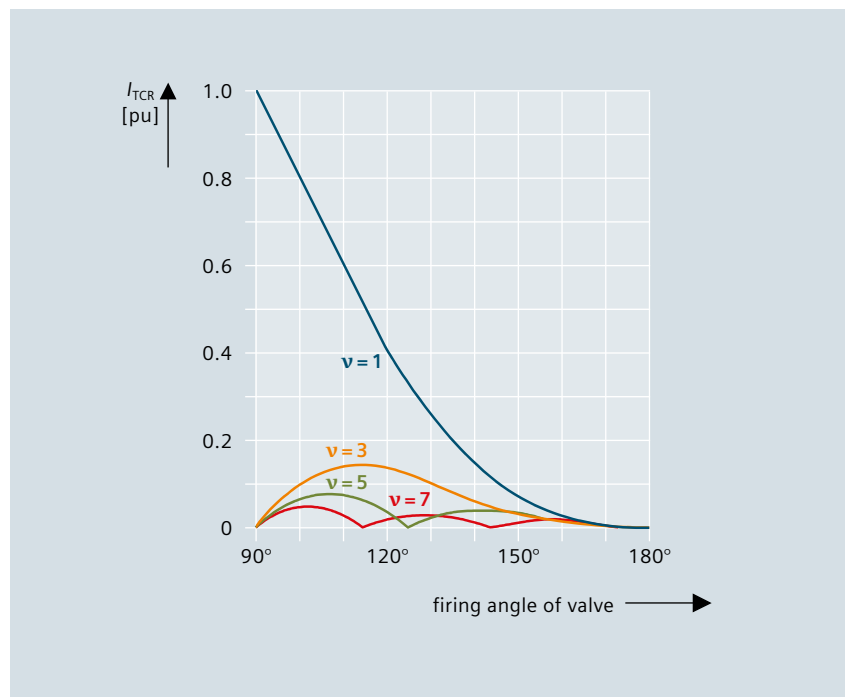

Fig. 4.1: Harmonics typical of a thyristor-controlled reactor

MSC/MSR Mechanically Switched Capacitors/ Reactors	SVC Static VAR Compensator	SVC PLUS® (STATCOM) Static Compensator
<ul style="list-style-type: none"> ➔ Switchgear ➔ Capacitors ➔ Reactors 	<ul style="list-style-type: none"> ➔ Thyristor Valve(s) ➔ Control & Protection ➔ Transformer ➔ Capacitors ➔ Reactors 	<ul style="list-style-type: none"> ➔ IGBT (GTO) Valves ➔ Control & Protection ➔ Transformer ➔ DC Capacitors
$52 \leq \text{kV} \leq 765$ $\sim 50 \leq \text{MVar} \leq 500$	$52 \leq \text{kV} \leq 765$ Control range: $\sim 50 \leq \text{MVar} \leq 1000$	$52 \leq \text{kV} \leq 765$ Control range: $\sim 50 \leq \text{MVar} \leq 500$
		 <p style="font-size: small; margin-top: 5px;">Further details can be found in separate SVC PLUS® brochure.</p>

Fig. 4.2: Shunt-connected FACTS devices

4.2 Mechanically switched compensation devices

4.2.1 MSC – Mechanically Switched Capacitor

Mechanically Switched Capacitors (MSCs) are a simple and low-speed solution for voltage control and network stabilization under heavy load conditions. Their utilization has almost no effect on the short-circuit level, while it increases the voltage at the point of connection.

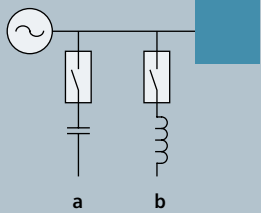
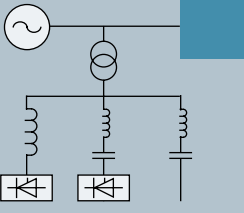
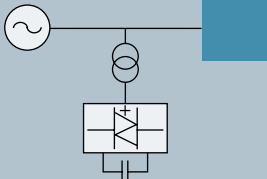
Key data of systems implemented:

$$U_N \leq 765 \text{ kV}$$

$$Q_N \leq 500 \text{ MVar}$$

4.2.2 MSR – Mechanically Switched Reactor

Mechanically Switched Reactors (MSRs) have exactly the opposite effect, and are therefore preferable for achieving stabilization under low load conditions, or at the end of long, radial AC lines.

4.2.3 MSCDN – Mechanically Switched Capacitor with Damping Network

As a more highly developed form of mechanically switched capacitor, the MSC with an additional damping circuit provides essentially voltage support without increasing existing system harmonics.

4.3 SVC – Static VAR Compensator

SVCs are a quick and reliable means of controlling voltage on transmission lines. With average response times ranging from 30 to 40 ms, SVCs are much faster than conventional mechanical switched reactors and capacitors (100 to 150 ms) and can also be used to actively damp power oscillations.

When system voltage is low, the SVC generates capacitive reactive power. When system voltage is high, it absorbs inductive reactive power.

The reactive power is changed by switching on three-phase capacitor and reactor banks connected to the secondary side of the transformer. Each capacitor bank is switched on and off by thyristor valves (TSC). Reactors can be either switched (TSR) or controlled (TCR). The main components of an SVC are shown in Fig. 4.4.

Key data of systems implemented:

$$U_N \leq 765 \text{ kV}$$

$$Q_N \leq 1000 \text{ MVAR}$$

4.3.1 Tasks of static compensation systems

Static compensation systems perform the following tasks:

- Stabilize voltage
- Control dynamic reactive power
- Improve transient stability
- Damp active power oscillations
- Increase power transfer capability
- Balance system voltages

The design and configuration of an SVC, including the size of the installation, operating conditions, and losses, depend on individual circumstances and the tasks to be performed.

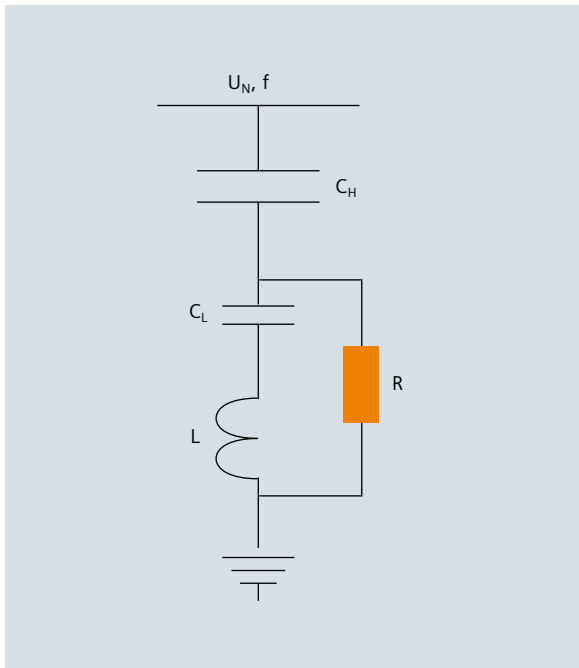
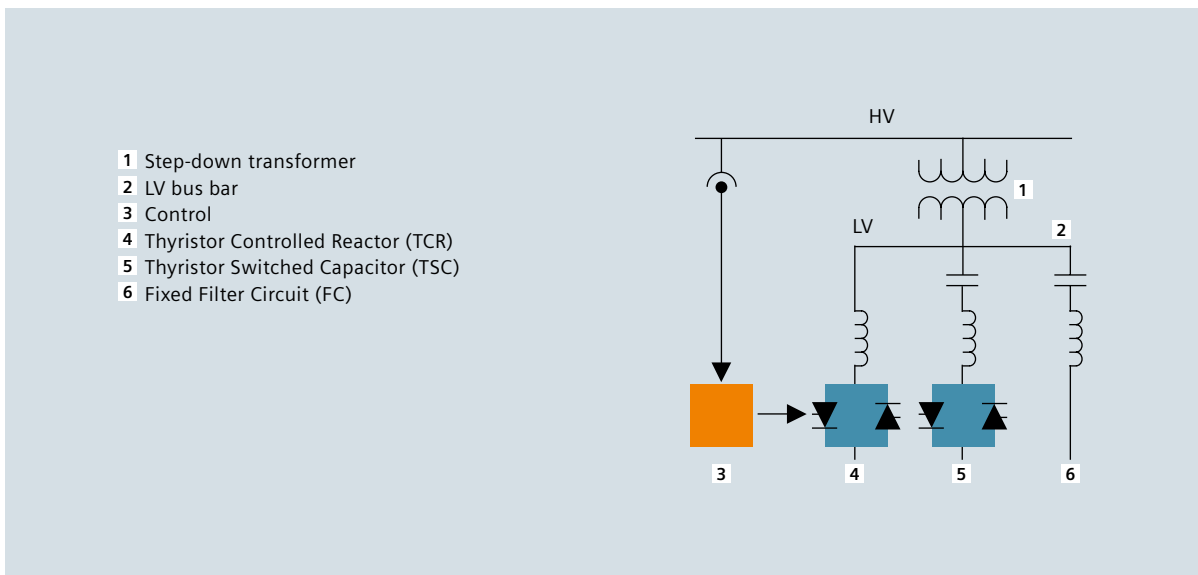

Fig. 4.3: Simplified single line of an MSCDN

Fig. 4.4: The SVC system combines various components as a function of the individual conditions in the power system to be optimized



4.3.2 V/I characteristic

The design of the TCR/TSR and TSC modules is determined by the desired current-voltage characteristic of the SVC. An SVC specification sets limits for modes of operation on the system side (Fig. 4.5).

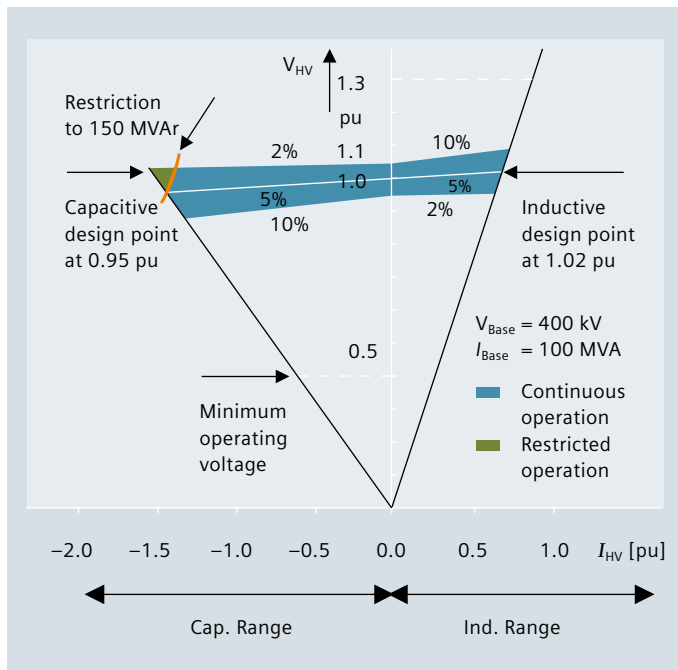

Fig. 4.5: V/I operating diagram of an SVC (HV side)

4.3.3 Losses

In Fig. 4.6, the compensator losses (P/S_r) are plotted as a function of compensator reactive output (Q/S_r) for two different compensator arrangements. The mean losses of configuration (a), which consists of a TCR combined with a Fixed Filter Circuit (FC), are distinctly higher in important operating ranges than those of the configuration with TCR, FC, and TSCs, represented by curve (b). If compensator losses in specific operating ranges are estimated to be high, a TCR/TSC combination may prove more advantageous economically than a TCR/FC combination.

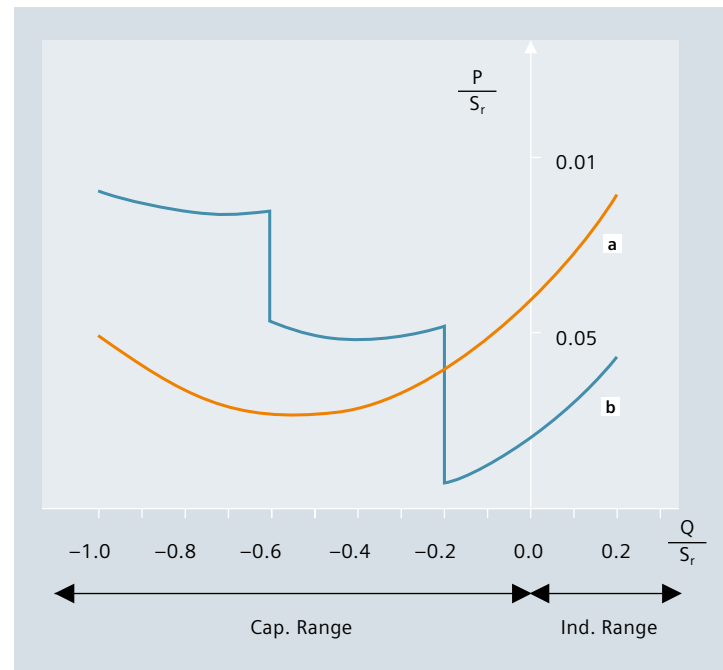
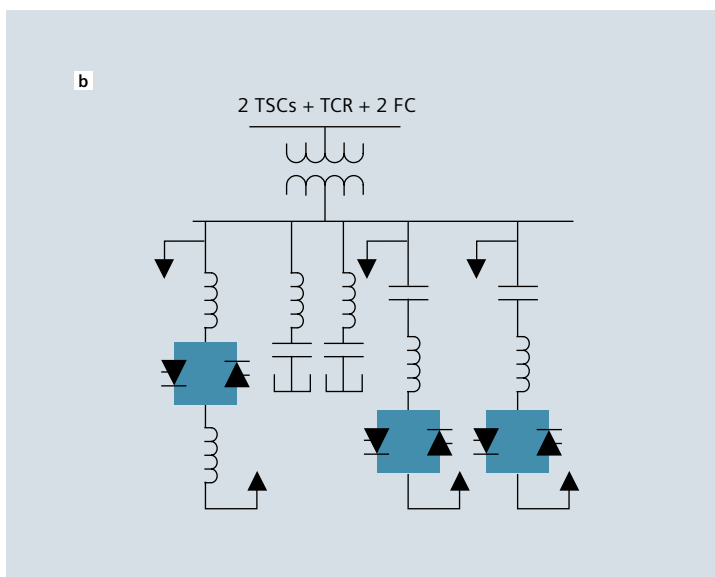
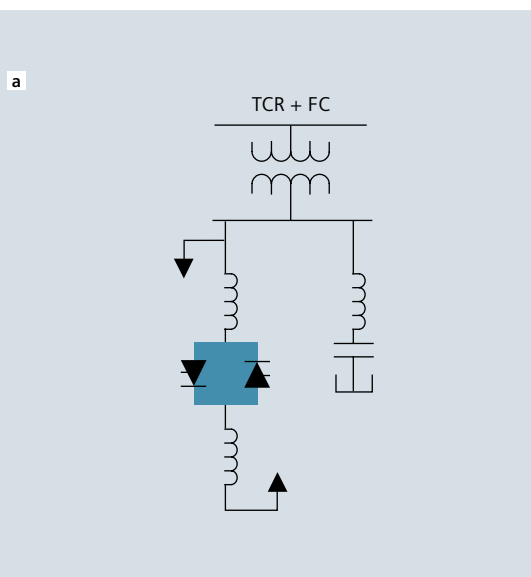

Fig. 4.6: Comparison of losses as a function of the reactive power output at the SVC



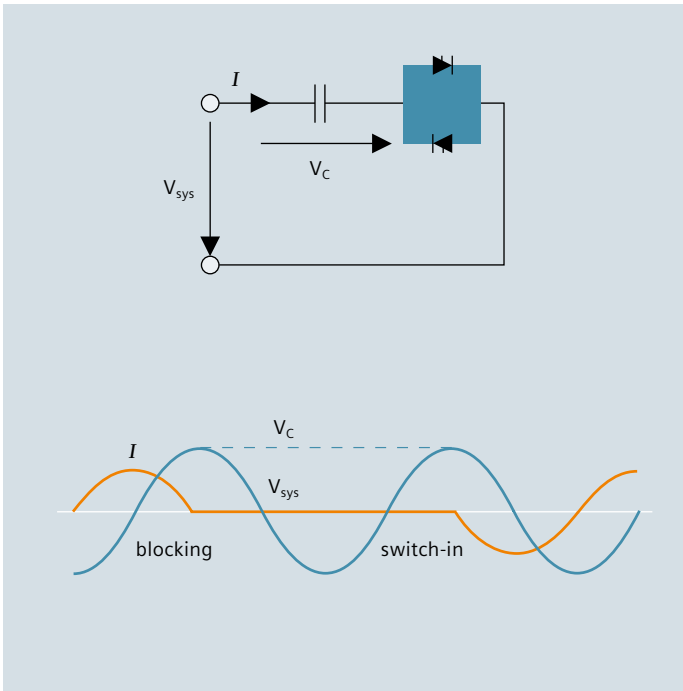

Fig. 4.7: Voltages and current of a TSC branch during valve conduction and blocking

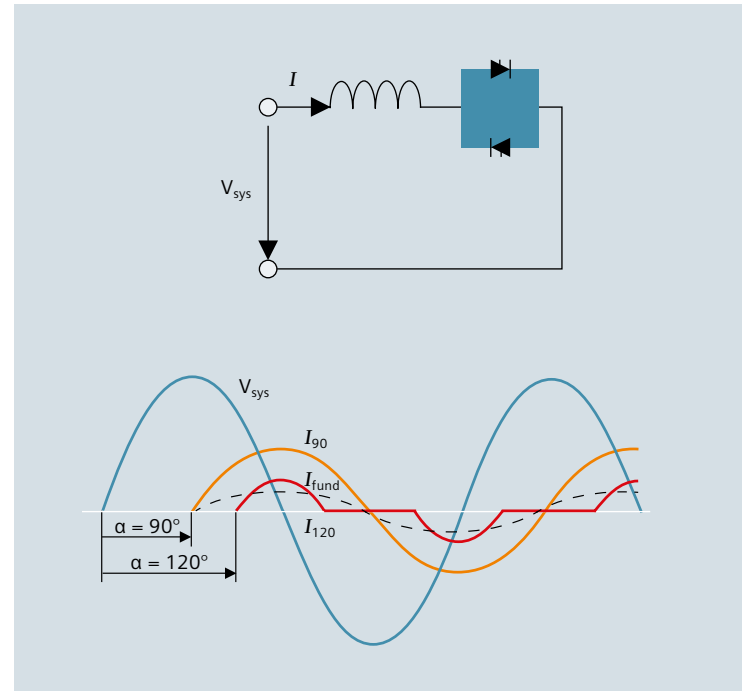

Fig. 4.8: Harmonics of voltages and currents of a TCR branch during valve conduction and blocking (---- shows the content of fundamental current of a control angle of 120°)

4.3.4 Thyristor-switched and thyristor-controlled devices (Fast VARs)

One of the most common FACTS components is the parallel static VAR compensator (SVC). Normally, a SVC is a combination of one or more of the following branches:

- TSC: Thyristor Switched Capacitor
- TSR: Thyristor Switched Reactor
- TCR: Thyristor Controlled Reactor
- FC: Fixed Filter Circuit (single-, double- or triple-tuned)

4.3.4.1 TSC – Thyristor Switched Capacitor

Due to transient phenomena at switch-on, TSCs are not continuously controlled but instead are always switched on and off individually as required by the system. Consequently, a TSC cannot inject a reactive current with variable amplitude into the system, meaning that it supplies either maximum reactive current or none at all. Through the precise triggering of thyristor valves, most of the transient phenomena at switch-on can be avoided. TSC branches do not generate harmonic distortions.

4.3.4.2 TCR – Thyristor Controlled Reactor

TCRs are used to continuously regulate the inductive reactive power from zero to the maximum, depending on the requirements, by means of current.

They do not generate transients; at the increased fitting angles (above 90°), however, they do generate harmonic currents that must be absorbed by filters.

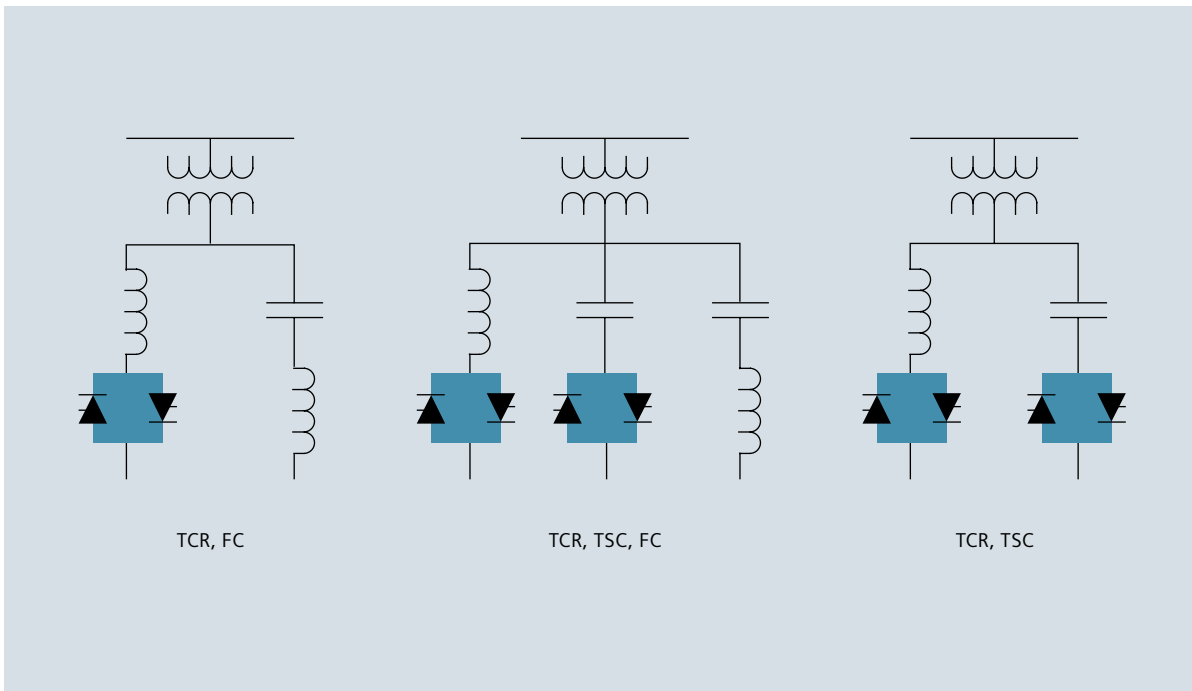

Fig. 4.9: Typical SVC configurations

4.3.4.3 TSR – Thyristor Switched Reactor

In order to prevent all harmonic currents when reactors are used, the reactors (like capacitors) can also serve as switches only, that is, as TSRs.

4.3.4.4 Configurations of SVCs

Fig. 4.9 shows some typical SVC configurations. The selection of the individual configuration depends on factors like investment costs, losses and availability figures.

4.3.5 Applications

The example 4.10 describes some of the many options available for reactive power compensation using static compensators.

A 600-km long, 500-kV double-circuit line interconnects three networks with a total load of 6700 MW (Fig. 4.10). The charging power of the line is approximately 1300 MVar cap.; 45 percent of this power is compensated by four shunt reactors of 150 MVar ind. each.

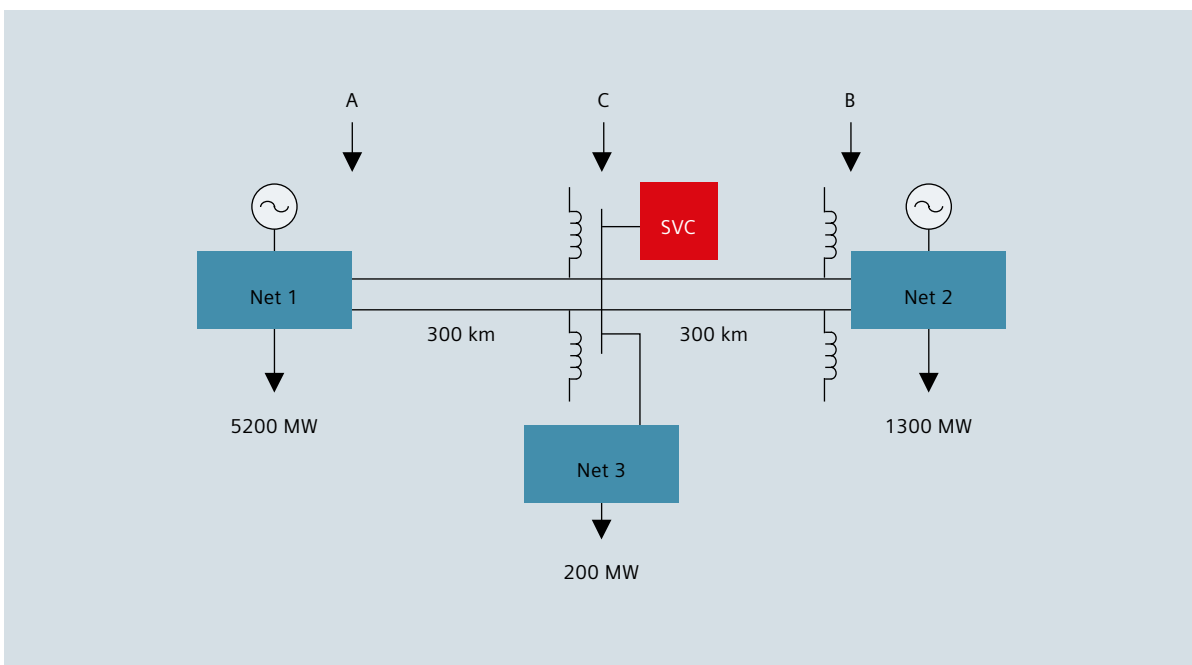

Fig. 4.10: Block diagram of the 500-kV transmission system

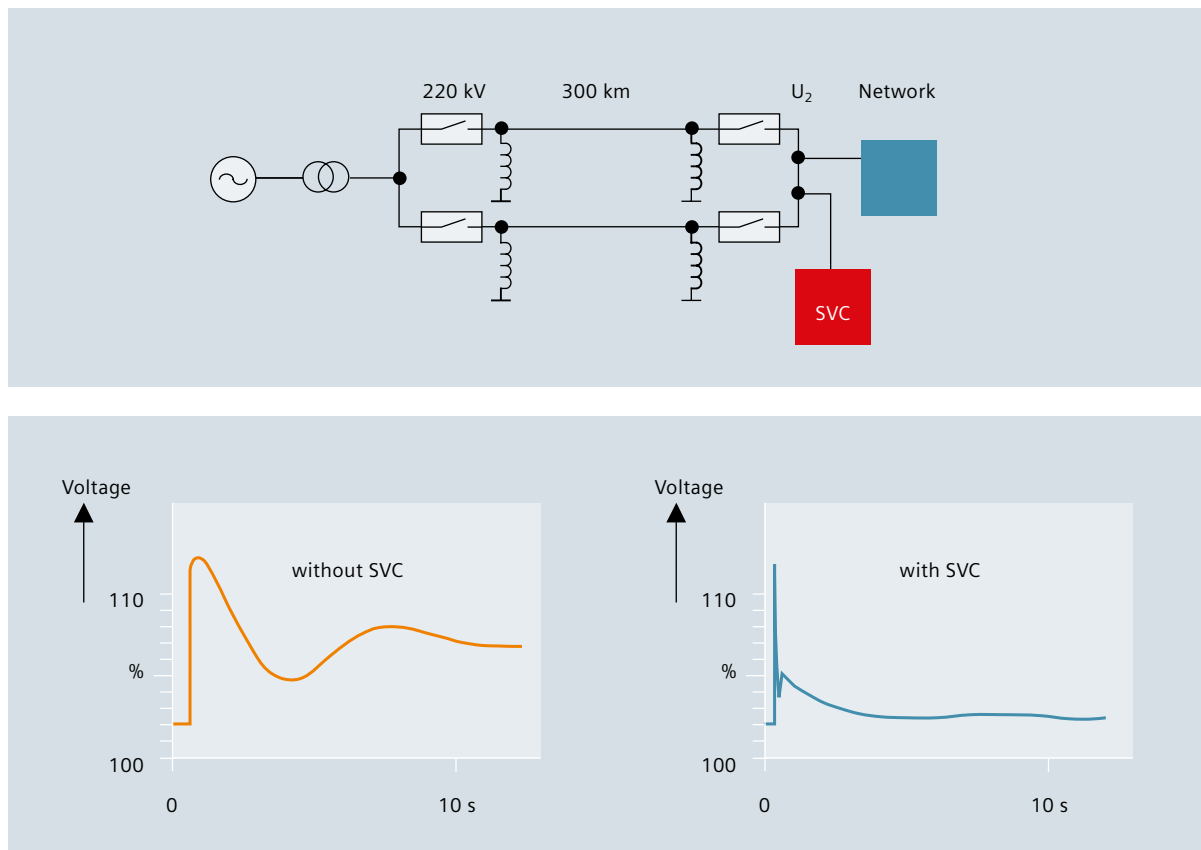

Fig. 4.11: Temporary overvoltage in System 3 caused by load rejection at A

The reactive power of the compensated line varies in operation by 500 MVar ind. The excess reactive power of 700 MVar cap. on no-load is reduced to 200 MVar cap. with maximum power transmitted.

An SVC with a rating of ± 200 MVar is connected at the middle of the transmission line.

For technical and economic reasons, the line should be operated under varying conditions at a constant voltage that is as high as possible. This maximizes the power that can be transmitted.

Matching the reactive power necessary to meet the operating conditions is carried out by controlling the 500-kV transformers in Power Systems 1 and 2 at the two ends of the lines. Such regulation is not possible in the middle of the lines because Power System 3 has no generating stations. Here, the static compensator can keep the voltage constant with practically no delay. Sudden changes in the reactive power – and thus also the voltage – are caused by switching operations.

When the double-circuit line between System 1 and System 3 is switched off, the voltage rises in System 3 by 10 percent U_n when one circuit is switched on without the SVC in service. With the SVC in service, the rise in voltage is suppressed from a peak of 10 percent U_n to 3 percent U_n within only a few hundredths of a second and subsequently regulated back to its original value (Fig. 4.11).

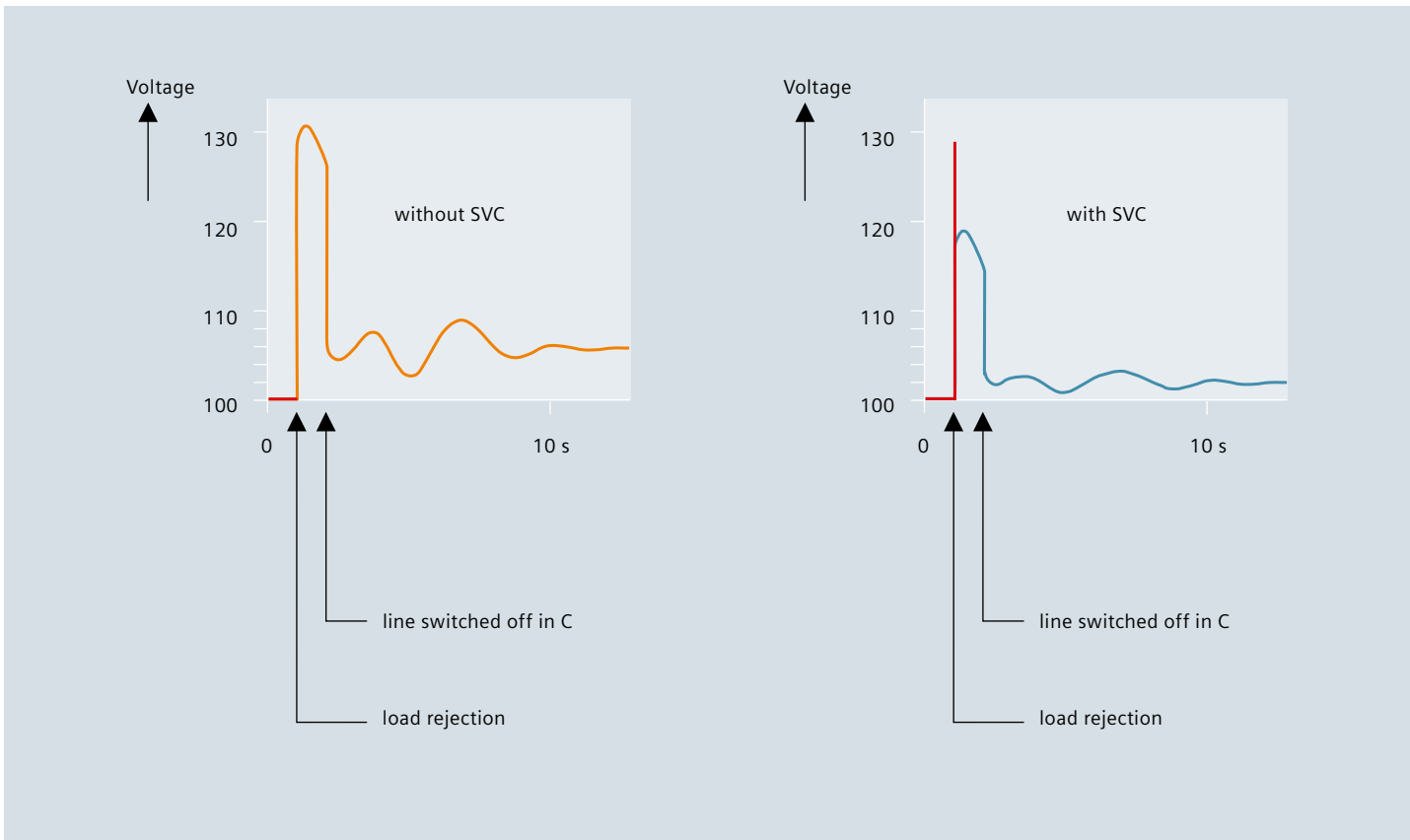

Fig. 4.12: Temporary overvoltage in System 3 upon switching on one circuit of the double-circuit line System 1 – System 3 at C

A second case addresses the conditions occurring during load rejection by opening both the circuits at A. The voltage rises to 133 percent U_n without the SVC and, except for a short peak, rises to only 120 percent U_n with the SVC in service.

Fig. 4.13 shows the effects on system voltage at the end of a 220-kV line operating at full load (a), at partial load (b), when a line segment fails at full load (c), and when there is a load rejection at the end of the line, with and without an SVC (d).

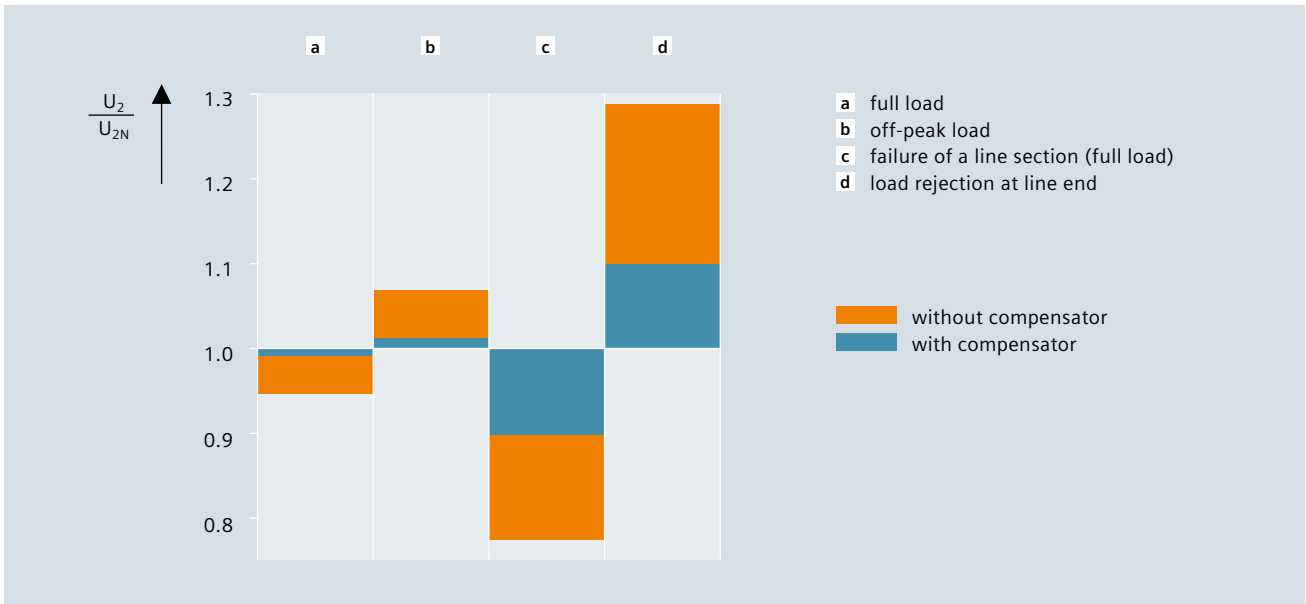

Fig. 4.13: Voltage ratios with/without SVC under different operating conditions

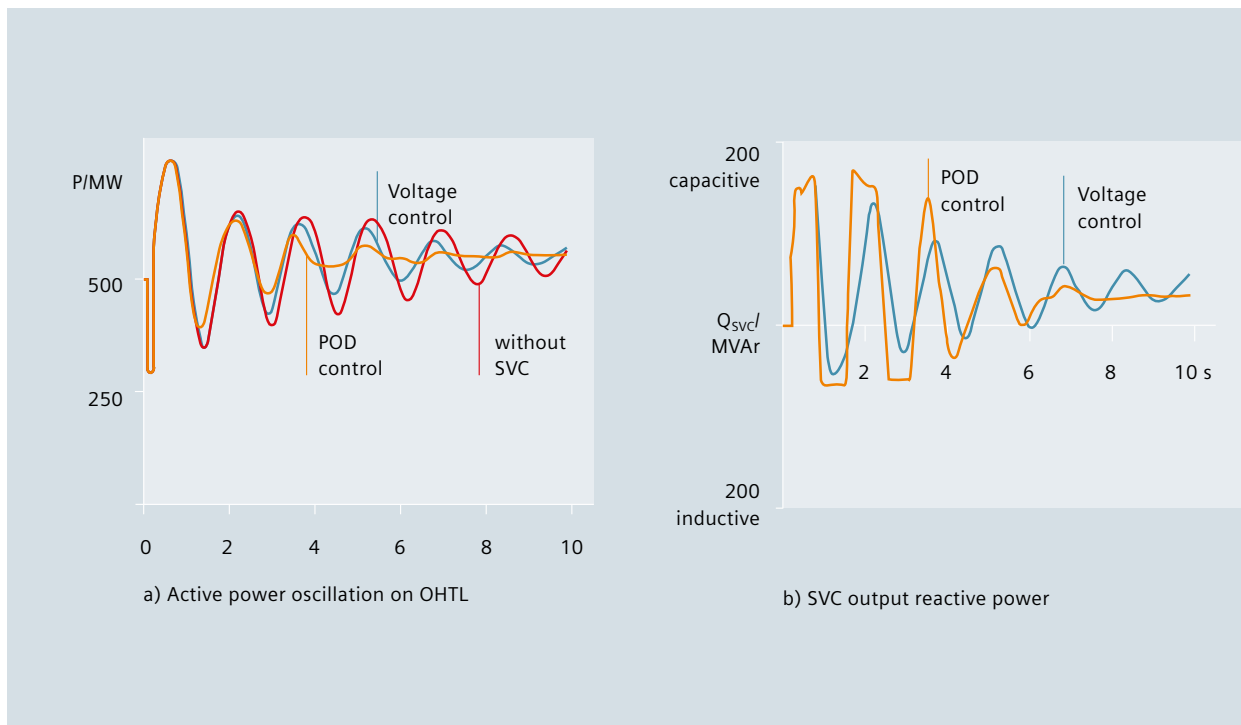

Fig. 4.14: Influence of the SVC with different control strategies

Siemens implemented an SVC system whose primary task was to damp power oscillations resulting from a system fault followed by switching off the faulted line section. Fig. 4.14 shows the performance curve, which is clearly stabilized following the installation of two SVCs, each with a control range from +150 MVAR (capacitive) to -75 MVAR (inductive).

Additional to voltage control, POD (power oscillation damping) control is implemented.

Summary

SVCs can be used to perform a wide range of compensation tasks in large transmission systems. Requirements vary greatly and are sometimes contradictory. The control system can be designed so that priorities can be flexibly assigned to one task or another, depending on current conditions in the power system.

4.3.6 Selecting the SVC configuration

Which SCV configuration will be chosen depends on the application. Please see Fig. 4.15 for details.

	High	Medium	Low
Permissible losses	TCR/FC	TCR/TS Comb.	MSR/MSC
Dynamic control range	TCR/FC TCR/TSC	TCR/TSC MSR/MSC Comb.	MSR/MSC
Permissible harmonic distortion limits	TCR/FC TCR/TSC	TCR/FC TCR/TSC	MSR/MSC

Fig. 4.15: Selecting the SVC



Fig. 4.17: Strathmore SVC, Australia (1 TCR/1TSC/3 Filter)

4.4 SVC PLUS (STATCOM)

Please refer to the separate available SVC PLUS brochure.

- | | |
|-----------------------|------------------------------|
| 1 SVC transformer | 7 Filter reactors |
| 2 Transformer cooling | 8 Filter circuit-breaker |
| 3 TCR reactors | 9 Valve and control building |
| 4 TSC capacitors | 10 Valve cooling |
| 5 TSC reactors | |
| 6 Filter capacitors | |

5 Series Compensation

5.1 Technology, theory, and basics

The transmission of active power is mainly limited by the impedance of the transmission line, comprising the ohmic resistance plus the capacitive and inductive reactance.

Tasks of series compensation

Series compensation provides the following benefits:

- Reduces line voltage drops
- Limits load-dependent voltage drops
- Influences load flow in parallel transmission lines
- Increases transfer capability
- Reduces transmission angle
- Increases system stability

For these tasks, Siemens offers various solutions that have already been proven in numerous applications.

5.2 Types

5.2.1 FSC – Fixed Series Capacitor

The simplest and most cost-effective type of series compensation is provided by Fixed Series Capacitors (FSCs).

FSCs comprise the actual capacitor banks and parallel arresters (Metal Oxide Varistors, MOVs), spark gaps, and a bypass switch. The surge arresters protect the capacitor from overvoltages during and after transmission system failures. The spark gap protects the arrester against excessive energy absorption; the bypass switch, in turn, protects the spark gap.

Three high-voltage switches serve to integrate the FSC into and isolate it from the transmission line (e.g., for maintenance purposes).

Key data of systems implemented:

$U_N \leq 765 \text{ kV}$
 $Q_N \leq 1500 \text{ MVar}$

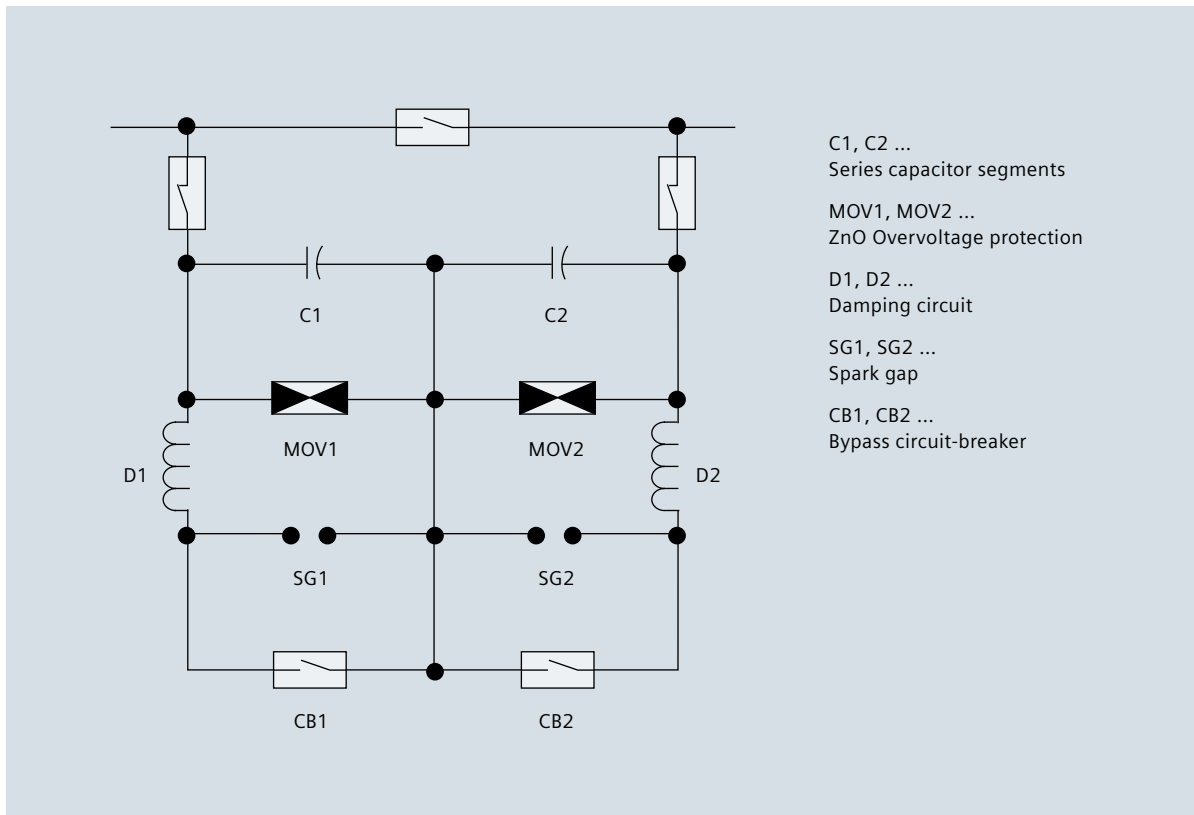

Fig. 5.1: Main components and configuration of a Fixed Series Capacitor (FSC) with two segments

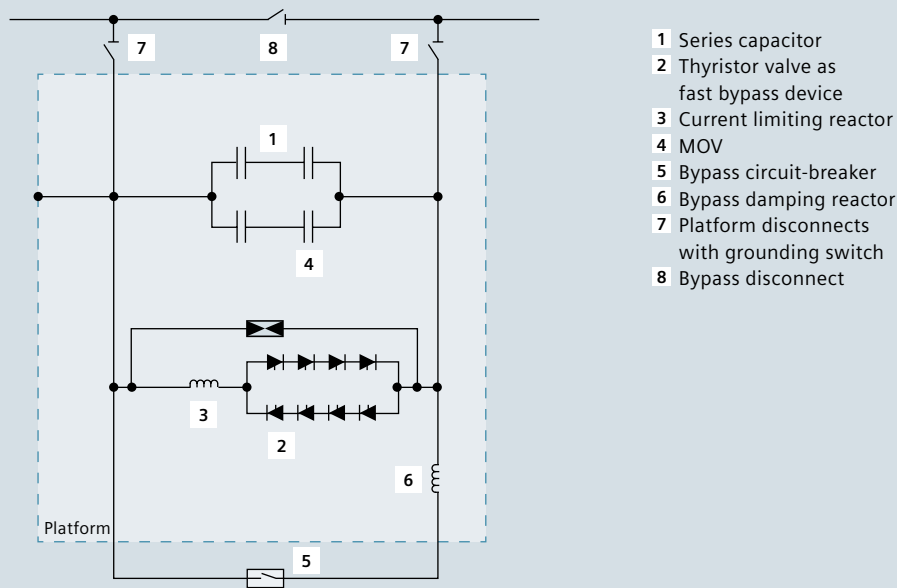

Fig. 5.2: Main components and configuration of a TPSC installation

5.2.2 TPSC – Thyristor Protected Series Capacitor

When direct light triggered thyristors are used, there is no need to install conventional spark gaps or surge arresters. Due to the very short cooling times of the Light Triggered Thyristor valves, thyristor-protected series capacitors can be quickly returned to service after a failure, allowing the transmission lines to be utilized to their maximum capacity.

Fig. 5.3 shows the sequence of events for a thyristor-protected series capacitor (TPSC) when a fault occurs in the line segment in which the series capacitor is operated. Whereas capacitor banks protected by conventional means often require several hours to cool after full energy absorption – and, consequently, until restart – the TPSC is fully operational within a fraction of this time.

With TPSCs, network operators can return to maximum power transmission faster and reduce the follow-up costs that were previously unavoidable. TPSCs are the first choice whenever transmission lines must be returned to maximum carrying capacity as quickly as possible after a failure.

Key data of systems implemented:

$$U_N \leq 500 \text{ kV}$$

$$Q_N \leq 401 \text{ MVAR}$$

5.2.3 TCSC – Thyristor Controlled Series Capacitor

Reactive power compensation by means of thyristor-controlled series capacitors (TCSCs) can be adapted to a wide range of operating conditions. It is also possible to control the current and thus the load flow in parallel transmission lines, which simultaneously improves system stability. Further applications for TCSCs include load oscillation damping and the mitigation of Subsynchronous Resonance (SSR).

The equivalent circuit diagram in Fig. 5.4 shows the basic configuration, comprising a capacitor and a parallel thyristor-switched reactor.

Fig. 5.5 shows the operating range of a TCSC. By variation of the firing angle α , the effective impedance of a TCSC can be varied. With $\alpha = 180^\circ$, the TCSC impedance equals the capacitor impedance, at about 148° , it is three times the capacitor impedance. With firing at $\alpha = 90^\circ$ and higher, the TCSC provides an inductive impedance.

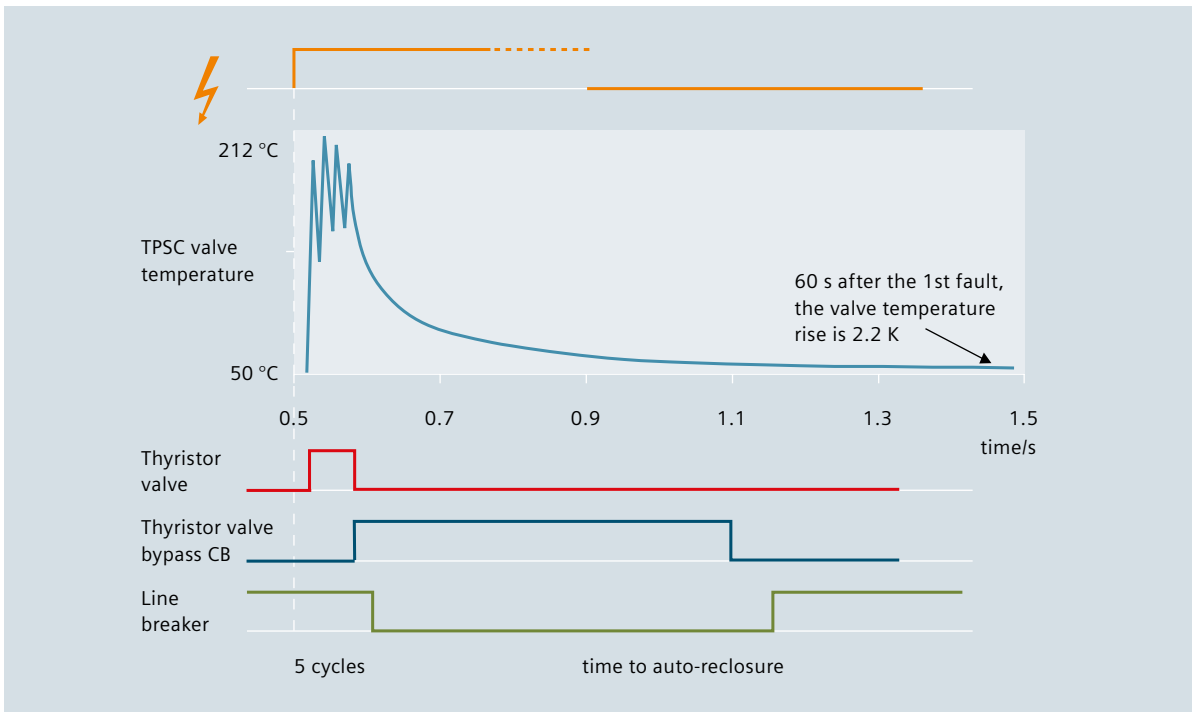

Fig. 5.3: Sequence of events in a TPSC installation when internal system faults occur

Advantages of the TCSC

The TCSC offers the following advantages over conventional fixed series compensation:

- Usable for load-flow control
- Power Oscillation Damping (POD)
- Higher degree of compensation
- Better capacitor protection thanks to thyristors
- Replacement of the spark gap

These advantages apply not only to brand-new installations but can also be implemented in existing systems.

Key data of systems implemented:

$$U_N \leq 500 \text{ kV}$$

$$Q_N \leq 200 \text{ MVAR}$$

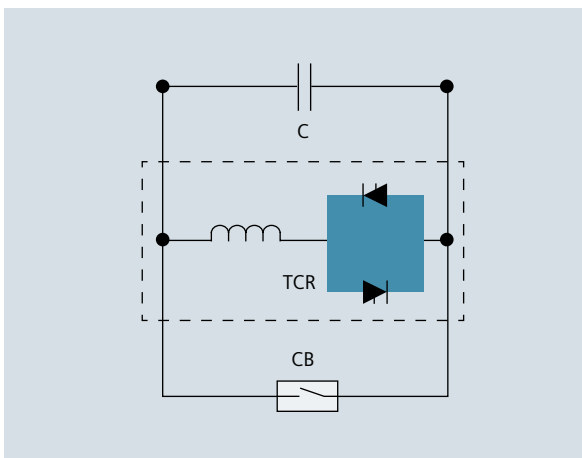

Fig. 5.4: TCSC

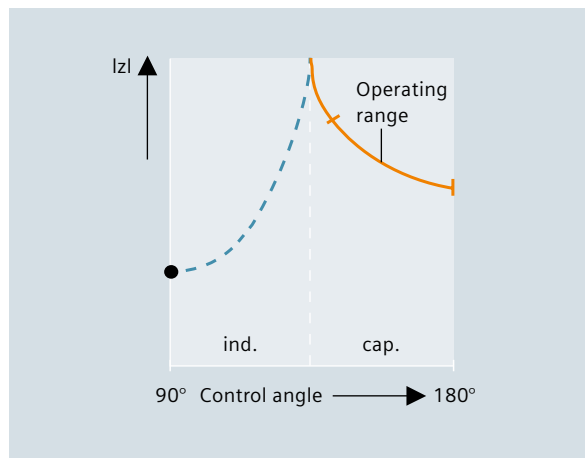

Fig. 5.5: Operating range of a TCSC



Fig. 5.5: An aerial view of the TCSC PingGuo

5.3 Layout

TCSC PingGuo,
State Power Southern Company,
China
500 kV
350 MVar (FSC)/55 MVar (TCR)

6 Protection and Control

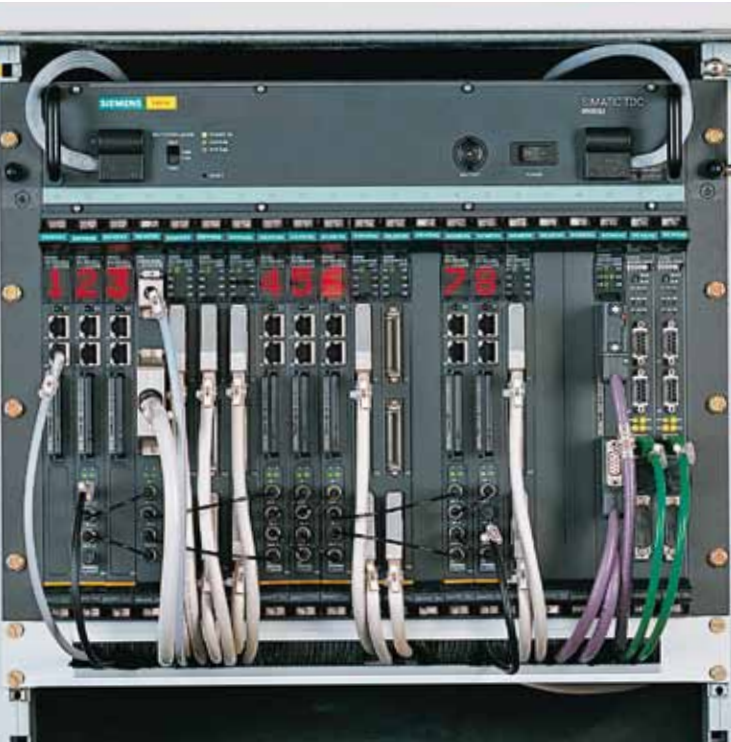

Fig. 5.6: Standard SIMATIC TDC control and protection system

6.1 Hardware for control and protection

Siemens offers the latest in control and protection for FACTS – the tried and tested SIMATIC TDC (Technology and Drive Control) automation system. SIMATIC TDC is used worldwide in almost every industry and has been proven in both production and process engineering as well as in numerous HVDC and FACTS applications. Operating personnel and project planning engineers work exclusively with a standardized, universal hardware and software platform, enabling them to perform demanding tasks more rapidly.

One of the main considerations in developing this automation system was to ensure the highest degree of availability of the FACTS – which is why all control and protection systems as well as the communication links are configured redundantly (if requested by the customer).

The new instrumentation and control technology also permits the use of a high-performance fault recorder operating at a 25 kHz sampling rate. This reduces the period of time between fault recording and the printout of the fault report from several minutes (previously) to 10 seconds (now).

To further improve redundancy management, special modules were developed that supplement the standard SIMATIC TDC automation system. Another new module in the instrumentation and control cabinet is responsible for issuing triggering signals to the thyristor valves.

Altogether, SIMATIC TDC with its high integration density takes up significantly less space in the plant than the previous technology.

Nevertheless, use of SIMATIC TDC is not limited to new FACTS. With its flexible interface design, it can easily replace existing systems. In this case, the measured values of existing plants are integrated in and further processed by the new control system. Because it requires so little space, the new technology can even be configured in parallel with the existing C & P system in order to integrate the FACTS with as little delay as possible.

6.2 Human Machine Interface

The interface between the operator and the plant (HMI = Human Machine Inter-face) is the standardized SIMATIC WinCC visualization system, which further simplifies operation and facilitates the adaptation of graphical user interfaces to the operator's requirements.

Fig. 5.7: All controls are fully tested with a real-time digital simulator



7 Converters for FACTS

7.1 LTT – Light Triggered Thyristors

Thyristors are a key element in controlling (switching on and off) the passive components in reactive power compensation systems (Fig. 7.1).

The system of direct light triggering developed by Siemens activates the thyristors with a pulse of light that lasts for 10 microseconds and has a peak power of 40 milliwatts. The device also incorporates over-voltage protection, so that it is self-protecting if the forward voltage exceeds the maximum permitted limit. The light pulse is carried by fiber optics at ground potential directly from the valve control to the thyristor gate.

Conventional high-voltage thyristor valve technology uses electrically triggered thyristors, which need a pulse with a peak power of several watts. This pulse is generated by complex electronic equipment placed alongside each thyristor. In turn, this electronic equipment, which needs an auxiliary power supply, is activated at ground potential by optical signals from the valve control. Substituting direct light triggering for this electronic equipment reduces the number of electrical and electronic components in the thyristor valve – and, consequently, the possibility of failure – by around 80 percent. This improves reliability and eliminates problems associated with electromagnetic compatibility. The other important fact about the new



Fig. 7.1: Easily assembled direct light triggered thyristors (left) have prevailed over electrically triggered models (ETT, right), especially in high-voltage thyristor valves



Fig. 7.2: Thyristor valve with wafer integrated overvoltage protection

thyristor technology is that long-term availability of electronic components for replacement purposes over a period of at least 30 years is no longer a problem.

Thyristor valves (Fig. 7.2) from Siemens are assembled from 4-inch or 5-inch thyristors, depending on the current-carrying capacity/rated current required.

Thyristor technology has been under constant development since the early 1960s. At the present time, thyristors can safely and economically handle blocking voltages of up to 8 kilovolts and rated currents of up to 4,200 amperes.

8 Complete Solutions

Complete solutions and services from a single source

The goal of modern power quality management is to provide stable, distortion-free voltage in a reliable manner. To this end, Siemens provides a single source for all the necessary FACTS equipment and a comprehensive range of complementary services (Fig. 8.2), including basic system design, modeling, network analyses, civil works, project management, functional performance tests, delivery, and installation, as well as commissioning, on-site tests, and training of operating personnel.

Siemens analyzes and calculates the power system requirements, develops customized solution concepts for complete system configurations and plants, and quickly implements them as turnkey systems. The delivery time for a typical SVC plant is from 15 to 24 months; FSC systems are ready to go in 10 to 15 months.



Fig. 8.1: Turnkey SVC Project

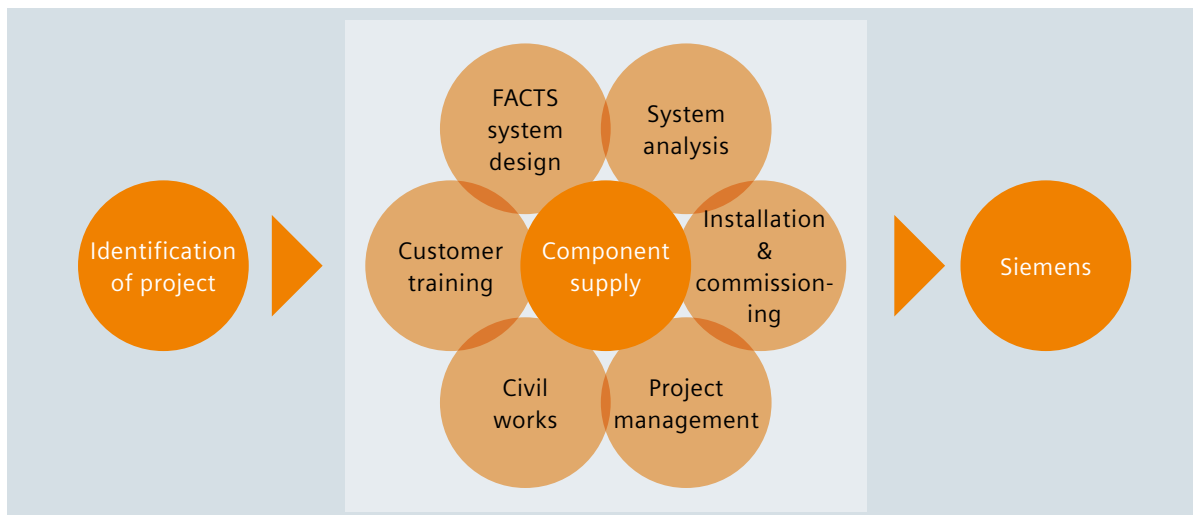

Fig. 8.2: Complete turnkey solutions and corresponding services from a single source

Published by and copyright © 2011:

Siemens AG
Energy Sector
Freyeslebenstrasse 1
91058 Erlangen, Germany

Siemens AG
Energy Sector
Power Transmission Division
Power Transmission Solutions
Freyeslebenstrasse 1
91058 Erlangen, Germany
www.siemens.com/energy/facts

For more information, please contact
our Customer Support Center.

Phone: +49 180/524 70 00

Fax: +49 180/524 24 71

(Charges depending on provider)

E-mail: support.energy@siemens.com

Power Transmission Division
Order No. E50001-G610-A114-V1-4A00 | Printed in Germany |
Dispo 30003 | c4bs No. 7803 |
TH 150-110675 | BR | 470770 | WS | 08112.0

Printed on elementary chlorine-free bleached paper.

All rights reserved.

Trademarks mentioned in this document
are the property of Siemens AG, its affiliates,
or their respective owners.

Subject to change without prior notice.

The information in this document contains general
descriptions of the technical options available, which
may not apply in all cases. The required technical
options should therefore be specified in the contract.