



SIEMENS



The image shows two men sitting at a desk with four computer monitors. They are looking at the screens, which display complex technical diagrams and data. The background consists of server racks in a control room environment.

www.siemens.com/energy/hvdc

Win-TDC

The State-of-the-Art Control and Protection System
for HVDC Applications from Siemens

Answers for energy.

Contents

Chapter	Theme	Page
1	Summary	3
2	Introduction	4
2.1	Abbreviations	4
3	Control of HVDC Systems	5
3.1	Control of Power Flow Using HVDC Systems	5
3.2	Basic Control Functions of a HVDC System	6
4	Control and Protection Hierarchy	7
4.1	Overview	7
4.2	Operator Control Level	8
4.2.1	Operational Concept	8
4.2.2	Human Machine Interface (HMI)	9
4.2.2.1	Sequence-of-Events Recorder	9
4.2.2.2	Trend System	11
4.2.3	Transient Fault Recorder	11
4.2.4	Remote Control and Data Exchange via the RCIs	12
4.2.5	Time Synchronisation System	12
4.2.6	Remote Access	13
4.3	Control and Protection Level	14
4.3.1	Common HW and SW Platform for the Control and Protection Systems	15
4.3.2	Station Control	16
4.3.3	Pole Control and DC Protection	18
4.3.3.1	Pole Control	18
4.3.3.2	DC Protection	20
4.3.4	Redundancy Management	22
4.3.5	Measuring System	23
4.3.5.1	General Concept	23
4.3.5.2	Hybrid-Optical DC Measuring	24
4.4	Field Level	25
4.5	Communication Systems	26
4.5.1	Lan System	26
4.5.2	Field Bus System	27
4.5.3	Performance of Telecommunication Media	27
5	Design Process, Testing Concept and Quality Assurance	28
6	Product Life Cycle of SIMATIC TDC	30
7	Conclusion Win-TDC Has Many Advantages for the End User	31

1 Summary

This brochure presents Win-TDC, the new Siemens HVDC Control and Protection System. It is intended for utilities/investors, planners and consultants that are planning to expand and enhance their transmission system with a new HVDC link or replace and upgrade existing installations.

Main advantages of Win-TDC

- Future-oriented technology for HVDC applications with estimated product life cycle for the next 25 years
- Very high availability due to complete redundancy at all levels with "Hot Standby" feature
- All Control and Protection Systems use the same well proven standard hardware/software
- Very compact design
- Human Machine Interface using windows-based, SIMATIC-standard operating system WinCC
- Very high performance Transient Fault Recorder
- Already a fully redundant Win-TDC Control and Protection System has been thoroughly tested for a monopolar HVDC scheme

Note:

Win-TDC SIMATIC Win CC
SIMATIC TDC (Technology and Drive Control)

The Control and Protection System plays an important role in the successful implementation of HVDC transmission. High reliability is guaranteed with a redundant and fault-tolerant design. Flexibility (through choice from optional control centres) and high dynamic performance were the prerequisites for the development of our Control and Protection System. Knowledge gained from over 30 years of operational experience and parallel use of similar technology in related fields has been built into the sophisticated technology we can offer today.

All Control and Protection components from the Human Machine Interface (HMI), Control and Protection Systems down to the state-of-the-art measuring equipment for DC current and voltage quantities have been upgraded to take advantage of the latest software and hardware developments. These Control and Protection Systems are based on standard products with a product life Cycle for the next 25 years.

The HMI is made up of Personal Computer (PC) workstations running on a Windows operating system. SIMATIC WinCC (Windows Control Centre) is the process display and control system utilised in the HMI. It is used in all applications and branches of industry including power generation and distribution. SIMATIC WinCC is a comprehensive system that includes plant operation, monitoring, operator guidance, Sequence-of-Events Recorder, event analysis, trend plots and archiving of operational data.

SIMATIC TDC (Technology and Drive Control) is a high-performance, state-of-the-art automation system, which allows the integration of both open-loop and high-speed closed-loop controls within this single system. It is especially suitable for HVDC (and other applications) which demand high closed-loop control performance and high computational accuracy.

DC currents and voltages are measured with a hybrid electro-optical system, DC current with a shunt located at HV potential, DC voltage with a resistive/capacitive voltage divider. Both systems use laser-powered measuring electronics so that only optical connections are made to the ground level controls – this achieves the necessary HV isolation and provides signal noise immunity.

Siemens provides proven hardware and software systems built around state-of-the-art technologies. Their performance and reliability exceed the requirements specified by transmission system operators for both new installations and control replacement.

2 Introduction

Our HVDC Control and Protection Systems have utilised digital computer technology since the early 1980's. At that time, Siemens introduced the SIMATIC programmable logic controller for switchyard controls, switching sequences and interlocking functions.

The high-speed multiprocessor control system, SIMADYN D, was developed as more powerful processors became available. The first application in the HVDC field for SIMADYN D was in 1987. The fast closed-loop controls and protections of the converters could now be implemented using programmable controllers.

At that time, the HMI was also designed utilising computer technology. A new fully guided operator interface was implemented. Features included are the alarm display, alarm sorting and filtering, archive functions, trend curves, and CIGRE performance recording.

In 1998, new developments such as decentralised controls and the hybrid electro-optical DC measuring system were introduced and put into commercial service.

SIMATIC TDC is the latest development in the Siemens family of Programmable Logic Controllers. This new system has replaced both the SIMATIC S5 and SIMADYN D in HVDC Control and Protection applications. SIMATIC TDC enables a larger integration of Control and Protection functions while maintaining redundancy.

At the same time, a high-speed optical bus was introduced for the SIMATIC TDC hardware. The introduction of the new Time Division Multiplexing (TDM) optical high-speed bus permits the distribution of the measured AC and DC system quantities amongst the Control and Protection processors via redundant optical busses.

The new Control and Protection System, Win-TDC, results in a much more compact design with a 50% reduction in space requirements. Furthermore, the integrated structure leads to a reduced component count which also contributes to improved reliability.

The new HMI is made up of PCs running on a Windows operating system. SIMATIC WinCC is the process display system utilised in the HMI. WinCC-based HMI systems are easily interfaced to Windows applications, allowing easy data collection for further processing outside of the HMI system.

Details of the latest Siemens HVDC Control and Protection System are described in the following sections to provide a better understanding of the philosophy and principles applied in the design and choice of hardware, thus allowing a comprehensive comparison and evaluation with other systems.

2.1 Abbreviations

AC	Alternating Current
CB	Circuit-Breaker
CFC	Continuous Function Chart
COL	Changeover Logic
CP	Communication Processor
CPU	Central Processing Unit
DC	Direct Current
DPT	Dynamic Performance Test
FB	Field Bus
FPT	Functional Performance Test
GPS	Global Positioning System
HMI	Human Machine Interface
HVDC	High-Voltage Direct Current
LAN	Local Area Network
LFM	Logic Function Module
PADU	Parallel Analog Digital Unit
RCI	Remote Control Interface
RPC	Reactive Power Control
RTDS	Real-Time Digital Simulator
SER	Sequence-of-Events Recording/ Sequence-of-Events Recorder
TFR	Transient Fault Recorder
TDM	Time Division Multiplexing
VBE	Valve Base Electronic
VDU	Video Display Unit

3 Control of HVDC Systems

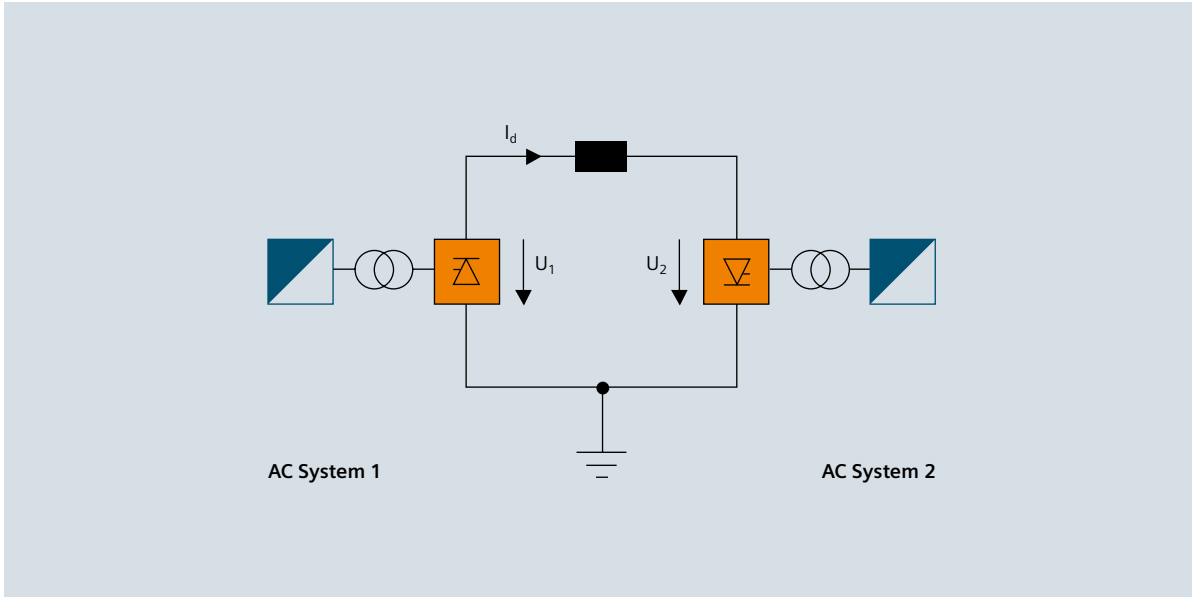

Fig. 3-1: Simplified HVDC System Diagram

3.1 Control of Power Flow Using HVDC Systems

The main elements of a simplified HVDC system are shown in Figure 3-1. At both stations, the converters are connected to their AC systems via special transformers. Appropriate firing of the thyristor valves of the converter bridges builds up the DC voltages U_1 and U_2 . The DC voltage magnitude and polarity of U_1/U_2 are defined by the respective firing angles.

A typical value for the rectifier station is about 15° el. and for the inverter about 140° el. At the rectifier station, a slightly higher DC voltage is needed to cause current flow through the DC system. DC current is controlled by a current controller, with power transfer always from the rectifier to the inverter station.

Line-commutated HVDC systems are very efficient, with the six valves of each bridge built from unidirectional thyristors. Due to this topology, DC current is also unidirectional and so to cause a power flow reversal, the voltage polarity generated by each converter must be reversed, see Figure 3-2. By changing the firing angle at both terminals, the converter voltage polarities become reversed so leading to a power reversal.

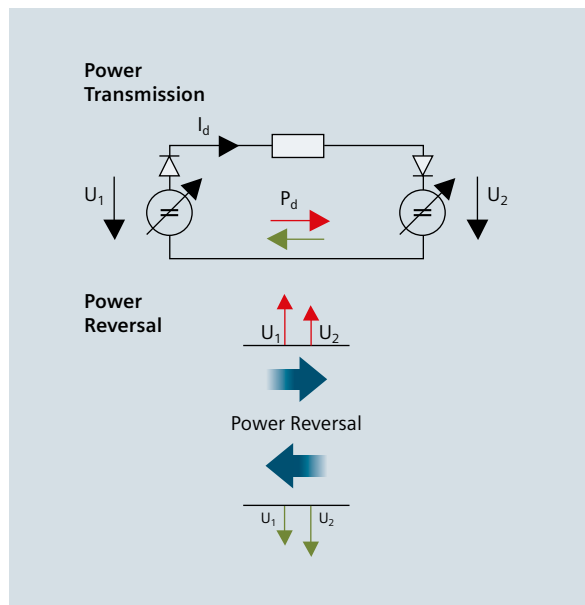

Fig. 3-2: Change of Power Direction (Power Reversal)

3.2 Basic Control Functions of a HVDC System

Each station of a HVDC System has three basic control points: the thyristor firing angles, the circuit-breaker states (of the filter elements) and the tap changer settings of the converter transformers, see Figure 3-3. These three control points are driven by the following control loops:

■ Converter Control

High-speed control of the thyristor firing angles controls the power flow through the converters of each station. Typically, a system is used to control the DC current (rectifier side) and the DC voltage (inverter side).

■ Reactive Power Control

Since both HVDC stations absorb reactive power (i.e. inductive) during power transmission, some compensation is required. This compensation must be variable since the inductive power load increases with active power. Each station has a reactive power controller to connect/disconnect capacitive filter elements from the AC system depending on the operating point of the HVDC system.

■ Tap Changer Control

To maintain optimised HVDC operation over a range of AC system voltages, control of transformer tap changers is provided. Tap changer control varies the AC voltage at the converter terminals to obtain an optimum steady-state operating point.

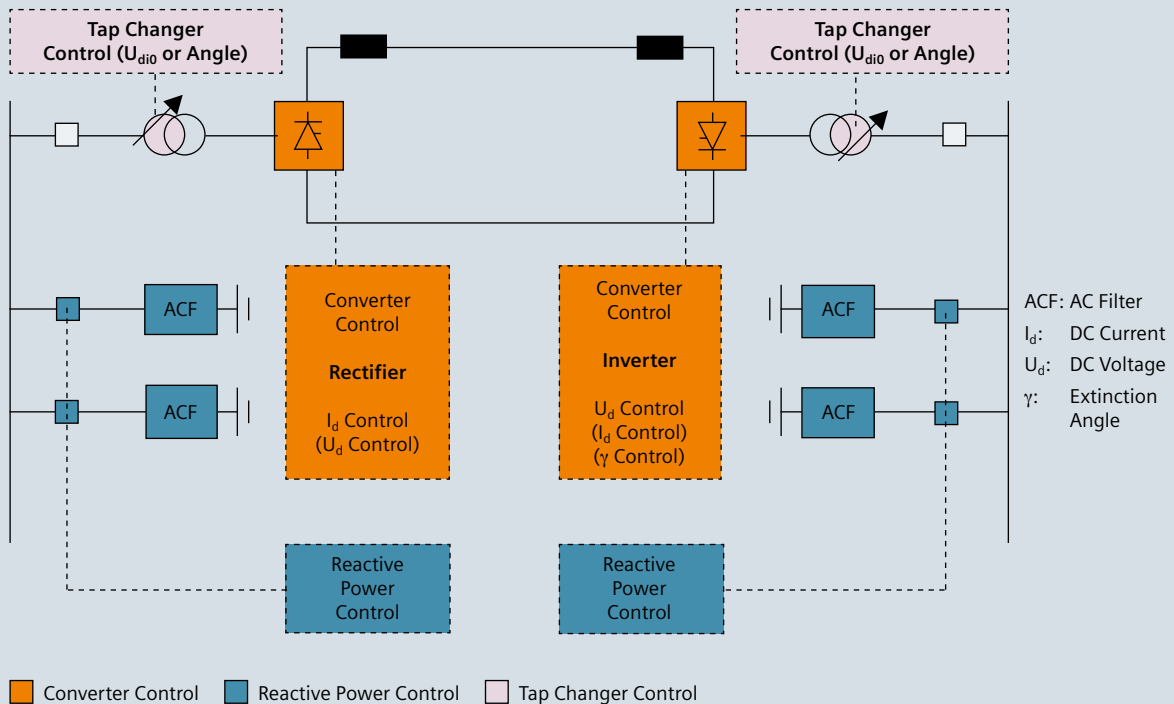

Fig. 3-3: Overview Control Functions

4 Control and Protection Hierarchy

4.1 Overview

The HVDC Control and Protection System at each converter station is structured into three main levels. Figure 4-1 shows the three levels of the HVDC control hierarchy for one converter station of a bipolar HVDC transmission scheme.

The Operator Control Level in each converter station of the HVDC transmission system mainly consists of the fully redundant HMI system (SIMATIC Win CC) and the Transient Fault Recorder System. The interface to the remote control facility at the higher network control level (e.g. the dispatch centre) and the telecommunication interface to the corresponding converter station for exchange of monitoring data are also part of this level. To have a common time base for all station equipment, a central master clock system is provided. This master clock system is synchronised at both stations by the satellite-based Global Positioning System (GPS).

The Control and Protection Level comprises the Station Control, the Pole Control and DC Protection and the Measuring systems. These systems are based on the latest development in the Siemens family of Programmable Logic Controllers SIMATIC TDC.

This new system has replaced both the SIMATIC S5 and SIMADYN D in HVDC Control and Protection applications. The high-speed system SIMATIC TDC enables a larger integration of Control and Protection functions while maintaining redundancy. At the same time, a high-speed optical bus was introduced for the SIMATIC TDC hardware. The introduction of the new Time Division Multiplexing (TDM) optical high-speed bus permits the distribution of the measured AC and DC system quantities amongst the Control and Protection processors via redundant optical busses.

The Field Level mainly consists of the HVDC converter (Transformers and Valves), the AC and DC Filters, the Hybrid-Optical DC Measuring, all cooling equipment and the complete AC and DC Switchyard. In Figure 4-1 only the I/O Units are shown.

Information exchange between the Operator Control Level and the Control and Protection Level is provided by a redundant 100-Mbit Local Area Network (LAN). The required information exchange between the Control and Protection Level and the Field Level is achieved via a redundant optical field bus system.

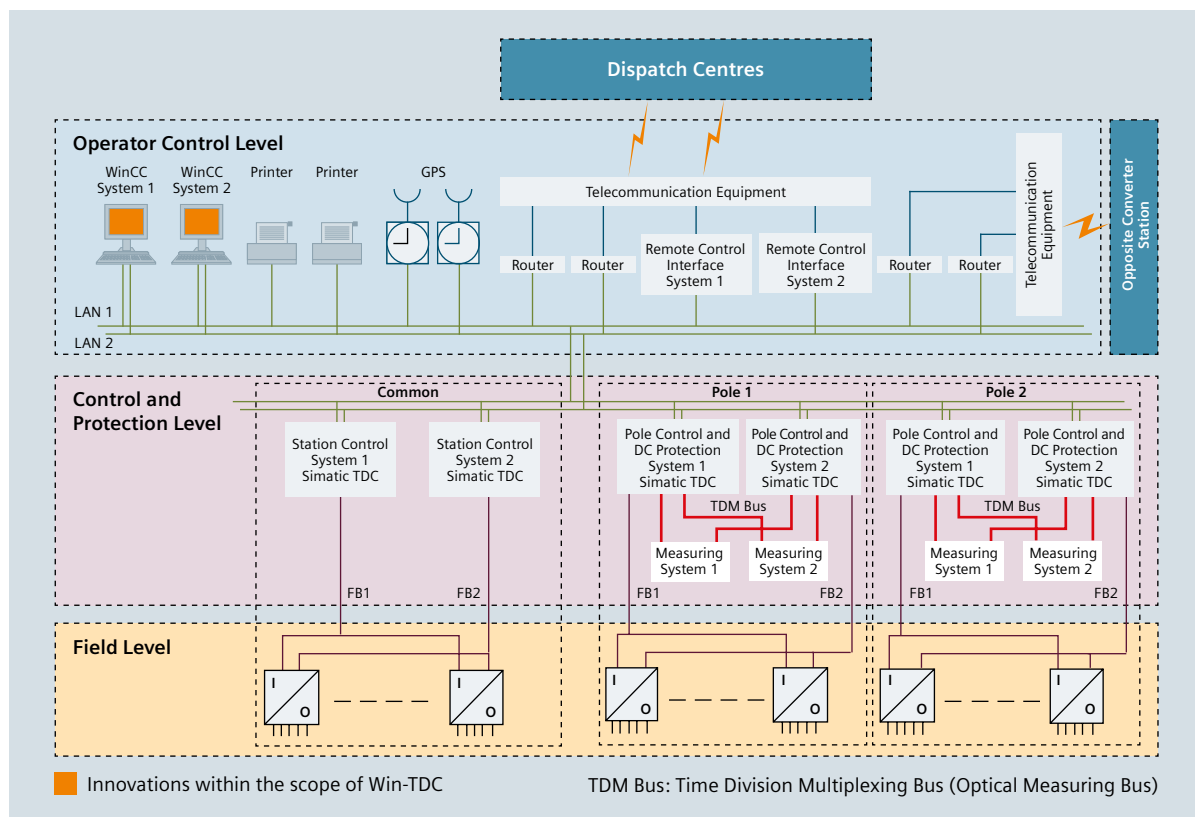

Fig. 4-1: Control and Protection Hierarchy (one Converter Station)

4.2 Operator Control Level

4.2.1 Operational Concept

The Siemens standard operator control concept is implemented in various HVDC systems and ensures high flexibility coupled with maximum safety in system operation. Control and monitoring functions, required by the operators to control the converters and the switchyards, can be carried out from various control locations.

Local control from the operator control room of the converter station itself is implemented with the SIMATIC WinCC HMI. The SIMATIC WinCC HMI is configured as a multi-server system. This means that the WinCC PCs operate independently of each other, with each PC providing the full control and display functionality. To ensure data consistency and interlocking of simultaneous operator actions, the servers communicate with each other. Furthermore, the HMI system is seamlessly integrated into the redundant Control and Protection System. This means that communication with the redundant SIMATIC TDC controls (via redundant local area networks) is fully supported. Remote control from customer's Load Dispatch Centre can also be implemented with WinCC. As an alternative, control and display functions can be integrated into existing HMI systems via a Remote Control Interface (RCI) or can be made available through the Internet, Intranet or dial-up networks.

Control Function Grouping

The available control functions are assigned to different function groups. For each function group, the active control location can be individually chosen from a list of possible control locations for the respective function group. The different function groups and possible control locations for each group are mainly determined by the system configuration and customer's operation philosophy. However, a typical control function grouping scheme is as follows:

HVDC-system-related control functions are functions that require coordinated operation on both converter stations, such as starting/stopping the power transmission, power/current reference value setting, changing the transmission direction, reduced DC voltage control. When the interstation telecommunication system is operational, these operator control functions are only available on one converter station (the so-called master station) and the necessary coordination between the control systems of both converter stations is automatically carried out by the control systems themselves. The master station can be freely assigned to either converter station by the operators with the request/release logic. However, if telecommunication is interrupted, the operators must manually coordinate their actions by phone.

Station-related control functions are functions that can be carried out for each converter station independently, such as DC switchyard configuration, reactive power control, AC filter control, connect/isolate converter pole to/from the AC grid, valve/transformer cooling system control.

Control Location Switchover Scheme

The control location for the different function groups can be independently assigned to any possible operator control system (local or remote) with a request/release logic: A location that is currently not in control can request control at any time, but the control authority is only transferred after the currently active location has released control. This switchover logic ensures that there is only one active location for any control function so that simultaneous operation from different locations is effectively prevented.

Control Modes

Operation of the HVDC system can be altered flexibly by selection of different system settings. A wide degree of freedom exists with regard to the order in which the operator can issue commands.

An automatic control mode is available for various control functions to provide a high degree of operator support. The operator initiates an automatic control sequence with a single command and the control systems carry out all necessary steps without intermediate operator action. For example, the operator may initiate a predefined control sequence to prepare a converter pole for energy transmission. Within this sequence, the valve cooling system will be started and the converter transformer feeder will be connected to the AC grid.

To provide even more flexibility in system operation, a manual control mode is available. This mode is useful during maintenance. In the manual control mode, a deeper understanding of the HVDC system and control concept is required, as all equipment can be operated without the restriction of a predefined sequence. Basic interlocking and plausibility checks are still available to avoid danger or hazards for personnel or equipment.

4.2.2 Human Machine Interface (HMI)

The top level of the control system is the HMI, which is located at the Dispatch Centres and at the converter stations' control rooms. It consists of operator PCs, which are used to send commands to the controls and field equipment, display the check-back information as well as to implement the SER and trend curves. Auxiliary systems such as low-voltage switchgear and diesel generators can also be controlled from the HMI if desired.

SIMATIC WinCC is the PC-based HMI software for Windows that is used for operator control and monitoring of HVDC applications, see Figure 4-2.

The basic system configuration includes functions that meet the industrial requirements for displaying of events, archiving of measured values, logging of all plant and configuration data, user administration and display. WinCC is designed for operation and monitoring of automated processes. With its powerful process interfaces and secure data archiving, this base system (which is industry and technology-independent) is suitable for universal use in any automation application.

Special software is used for the communication with the redundant HVDC control systems via the redundant Local Area Network (LAN) to meet the high availability and performance requirements of HVDC applications. The redundant WinCC computers are configured as a so-called multi-server system, which means that two or more WinCC systems are operating in a redundant manner – all necessary control and display functions are available on each system. WinCC's simplicity and transparency, as well as its powerful configuration functions enable a drastic reduction of engineering and training requirements, greater flexibility of personnel and greater operational reliability.

WinCC is available in many languages, e.g. simplified Chinese, traditional Chinese, Korean and Japanese languages. The localised WinCC versions are based on localised versions of Windows and provide a configuration interface in the relevant language containing all WinCC functions.



Figure 4-2: HMI System at the Functional Performance Test

4.2.2.1 Sequence-of-Events Recorder

To ensure efficient operation of HVDC systems and AC substations, under all operating conditions, Siemens provides a state-of-the-art operator interface based on the latest computer technology. With its powerful sorting, filtering and archive access functions, the integrated Sequence-of-Events Recorder (SER) display supports the operator in fast fault analysis as well as in the creation of customised reports. The data logged by the SER system (see Figure 4-3) includes all normal plant events such as operator commands and status indications as well as abnormal events such as alarms.

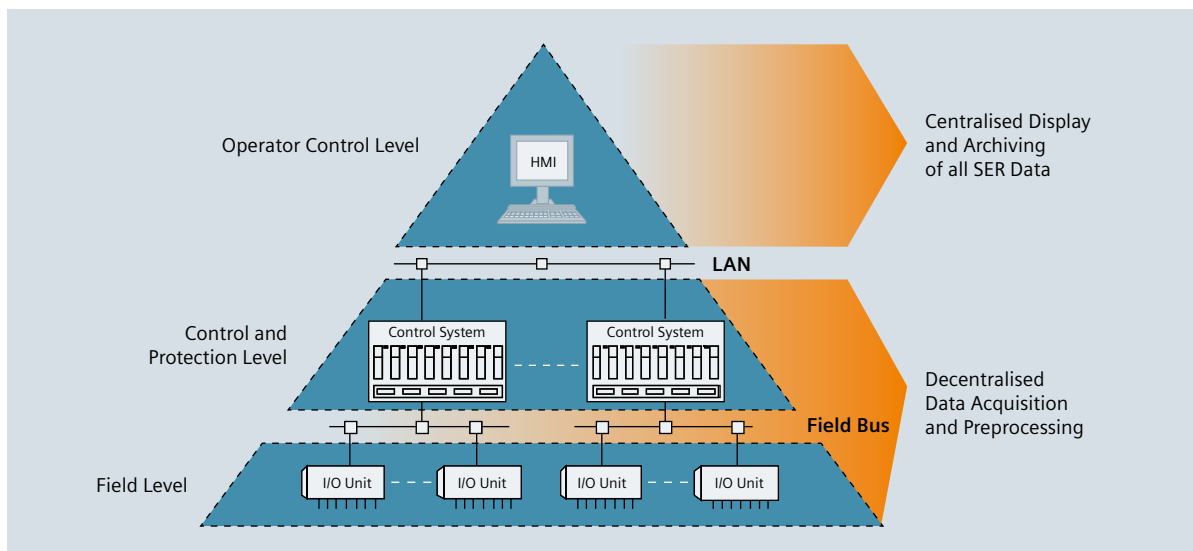

Figure 4-3: Decentralised SER Data Acquisition in Combination with Centralised Data Display

137	21/03/2003	09:55:02.958	200240	COME	EARTH SWITCH FAILURE	WRN	~20CF11G	0
138	21/03/2003	09:55:02.958	200201	COME	ISOLATOR OPEN	STAT	~20C03.C.G2	0
140	21/03/2003	09:55:02.958	200209	COME	ISOLATOR OPEN	STAT	~20CF21-G1	0
141	21/03/2003	09:55:02.958	200213	COME	ISOLATOR OPEN	STAT	~20CF22-G1	0
142	21/03/2003	09:55:02.958	200217	COME	ISOLATOR OPEN	STAT	~20CF23-G1	0
143	21/03/2003	09:55:02.958	200221	COME	ISOLATOR OPEN	STAT	~20CF24-G1	0
144	21/03/2003	09:55:02.958	200225	COME	ISOLATOR OPEN	STAT	~20CF25-G1	0

Figure 4-4: SER Display

Signals originating from the field devices and other equipment are acquired, time-tagged and pre-processed by decentralised I/O units. The data is collected by the control systems via a field bus, further processed and then transmitted to the HMI via a Local Area Network (LAN). All SER data is displayed and archived on the HMI.

Decentralised data acquisition and preprocessing in combination with centralised display and archiving provides the following advantages:

- The decentralised data acquisition and preprocessing concepts provide the customer with the most effective and reliable SER system for his specific requirements. This can be achieved by optimising the number and location of the I/O units as well as by considering redundancy aspects of communication systems, controls and HMI.
- Being independent of the underlying data acquisition structure, centralised SER data display and archiving leads to a consistent data evaluation interface, thereby supporting the operator in safe and efficient control of the plant during normal as well as during contingency operating conditions.
- The transmission of SER data to remote load dispatch centres can be implemented by connecting an additional Remote Control Interface (RCI) to the LAN. The RCI also receives SER data from the control systems and routes the data to the dispatch centres.

Each SER data point is time-tagged with a resolution of one millisecond. The time tag allows the exact chronological order of any SER record to be determined, thus providing important information for fault analysis. Time tagging is done either in the distributed I/O units or in the control systems, both by occurrence and clear ance of the event. All I/O units, control systems as well as the HMI are synchronised by one master clock to ensure the correct time tagging.

For safe and efficient operation of the plant, fast fault localisation and clearance is essential. A sophisticated event classification scheme greatly facilitates the identification of the most critical events. Therefore, each SER data point is assigned to one of the following event classes describing its severity (the event classes can be easily adjusted to customer requirements, e.g. special naming conventions):

- Emergency (EMCY): For faults leading to a forced shutdown of a system or subsystem, e.g. a trip of a circuit-breaker due to a short circuit
- Warning (WRN): For faults which degrade the system's functionality or performance, e.g. a faulty motor drive of a disconnecter
- Minor Warning (MNOR): For faults which do not degrade the system's functionality or performance, e.g. a faulty control system cooling fan
- Status Event (STAT): For equipment status changes, e.g. a check-back signal "circuit-breaker closed"
- Command (CMD): For operator-initiated control actions, e.g. a command "close circuit-breaker"

Group events combine any desired number of single events to one group. These events are useful in providing remote load dispatch centres with condensed SER data over low capacity communication links and in giving the operator a quick and comprehensive over view of the plant condition by displaying only group events.

The SER data display (see Figure 4-4) and archiving module is seamlessly integrated in the HMI to keep the operational philosophy consistent, so that all necessary tasks can be carried out most efficiently.

Depending on the operating condition of the HVDC system or AC substation, different information is required to support the operator in safe and efficient system operation. The data analysis functions described below allow the operator to easily adjust the SER display to specific operating conditions and requirements:

- Filtering is implemented by the event selection function. The number of displayed events can be limited by specifying any desired combination of event classes, e.g. only emergencies and warnings.
- The event list can be sorted according to all displayed event information, e.g. sorting by number, time, device, etc.
- The archive access function allows the operator to retrieve SER data from the archives on hard disk as well as on backup media. The desired time period as well as additional filter criteria (event class, device, group, event number band) can be specified. Once the archived data is loaded to the event list, all filtering and sorting functions described above are also available.

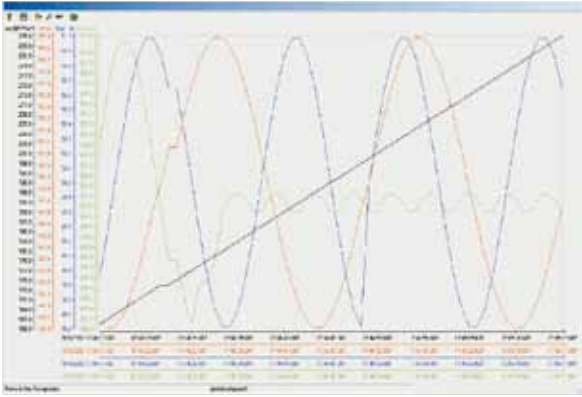

Figure 4-5: Tag Logging Displaying Multiple Simultaneous Trends

4.2.2.2 Trend System

A convenient and user-friendly graphical operator interface is provided to display and record historical data from process control states. The configured process tags (signals) can be visualised in a “real time” format on the HMI screen, see Figure 4-5. Different display formats are available having freely defined X-axis and Y-axis. A feature which differentiates between archiving/display cycles and acquisition cycles allows operators to configure the displays as personally desired, without sacrificing information loss.

In general, the acquisition and archiving cycles can be independently configured for each archive of the WinCC archiving system. The cycle times are defined for each tag or tag group during the configuration phase and are applied in run time.

4.2.3 Transient Fault Recorder

The Transient Fault Recorder (TFR), ibaScope, is a powerful super-high-speed data acquisition system that enables data acquisition with sampling frequencies of up to 100 kHz. Typically 12.5 kHz is used. The download time of a typical fault file has been greatly reduced down to 10 seconds. This speeds up troubleshooting and can help reduce system downtime.

The TFR is complemented with an off-line engineering analysis tool that includes math functions, digital filters, zooms and statistics. This software tool is called the ibaAnalyzer and is available as freeware worldwide.

In order to retrieve data from a process, the ibaScope requires sampling hardware such as Padu (Parallel Analog Digital Unit). Various analog inputs are available, 10 V, 20 mA, 1 Aac (16 bit and 100 X I_{nom} for 1s, 30 X I_{nom} for 10 s) and 250√3 Vac. Peak AC currents of up to 2 X√2X40 X I_{nom} can be displayed. Dry contacts or potential-free electronic binary outputs can be connected to the Padu’s binary inputs.

The Data Acquisition PC and the Padus are connected via fibre-optic links, see Figure 4-6.

The features of the ibaScope are:

- Simple adjustment of windows, toolbars, colours and lines
- Oscilloscope view
- On-line FFT view (multiple FFTs or FFT vs. time in a 3D waterfall view)
- Report usage diagnostic tool
- Software interface for individual channel gain and filtering configuration in the Padu
- 4 fully independent recording levels (4 files at the same time)
- Manual, continuous or triggered storage
- Highly flexible triggering configuration for starting and stopping data acquisition
 - Threshold
 - Constant
 - Change rate
- Ability to program triggers with logical OR/AND functions of all available input signals
- Storage speed profiles for individual or channel groups
- Automatic file naming
- Hard disk space management

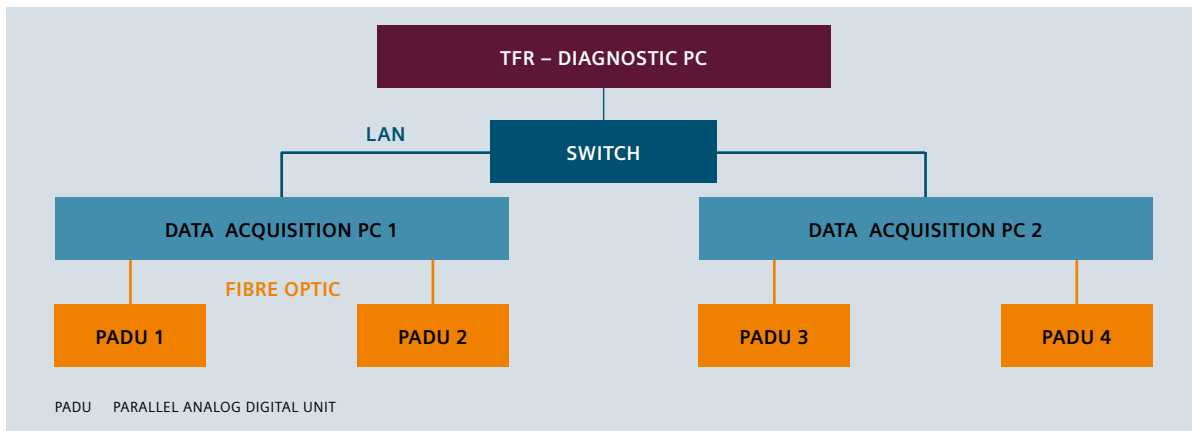

Fig. 4-6: Transient Fault Recorder Overview

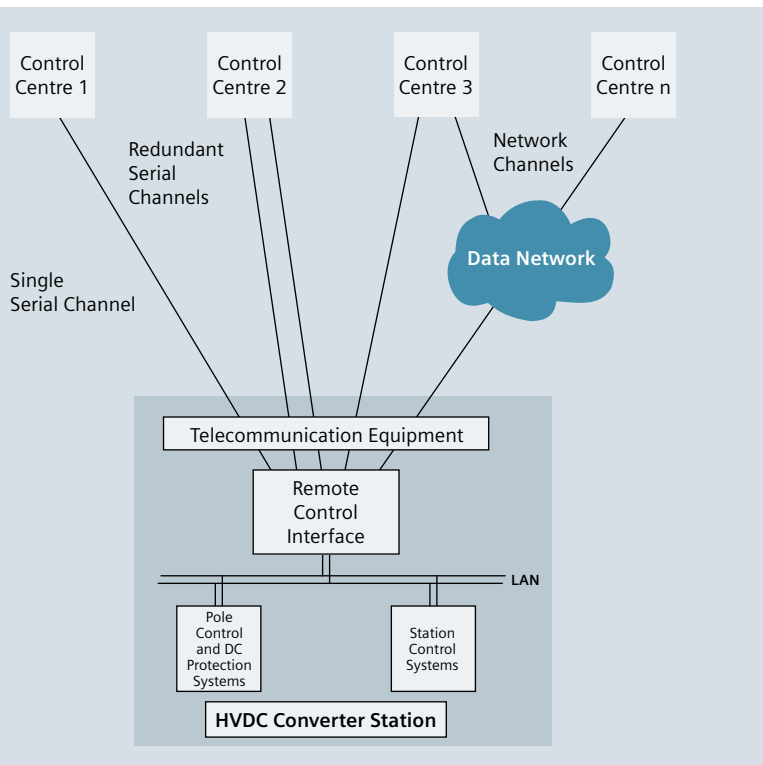

Fig. 4-7: Remote Control Interface (RCI) Embedded in the Communication Facilities

4.2.4 Remote Control and Data Exchange via the RCIs

Integration of the HVDC HMI system into the utility's overall HMI system located at the control centres (load dispatch centres) has become an important feature. The utility's overall HMI system requires input of the main operational data from the HVDC link (for real-time monitoring) and the ability to issue commands and setpoint changes from the control centre. The link between the HVDC Control and Protection System is provided by the Remote Control Interface (RCI). The RCI communicates with the station control and pole control via the redundant station LAN as shown in Figure 4-7. It permanently receives monitoring information from the control systems. These data streams are processed and stored in a memory-resident real-time data base. So, the complete and up-to-date HVDC process information is available at any time. For incoming commands and setpoints from the control centres, authentication checks are performed, a command is only forwarded to the control level if all required conditions are fulfilled. Command arbitration between different control centres is also possible. The RCI supports a wide variety of communication media such as leased lines, fibre-optic links, power-line carrier, microwave links or data networks.

All major standard or open communication protocols are supported, such as

- IEC 60870-5-101
- IEC 60870-5-102
- IEC 60870-5-104

- ELCOM-90
- DNP 3.0
- SC1801 and others

Any other protocol can be provided in accordance with the actual control centres' requirements. Multiple remote data channels are supported. This means that several remote control centres can be connected and supplied with real-time data simultaneously. The connection to each particular control centre can consist of one or two (main and backup) data channels. The connected control centres can run different protocols. The individual data sets can be defined for each connection independently. The standard system configuration is a single (non-redundant) RCI unit. In case highest availability is required, a redundant system in hot-standby configuration can be supplied as well.

4.2.5 Time Synchronisation System

All Control and Protection subsystems within the converter stations are synchronised by the Time Synchronisation System, see Figure 4-8. For chronological analysis, the events, status indications and alarms are time-stamped. They receive their time information from the centralised Master Clock (see Figure 4-9). To ensure high availability, the Time Synchronisation System is designed in a redundant configuration and consists of two fully separated units in the control room of each converter station. Time synchronisation outside the control building is achieved with the Master Clock via optical fibres. With time synchronising, an accuracy of at least 1 ms is achieved. To achieve a very high availability, the distribution of the time synchronisation is duplicated up to the I/O units.

Various standardised synchronisation methods such as

- Adjustable pulses as 20 mA or voltage signals
- DCF77 (the European radio time signal)
- IRIG (A and B) time code
- Asynchronous messages
- Ethernet frames OSI unicast and broad cast as well as SNTP

and programmable interfaces make it possible to provide every device in the plant with the necessary precision for time information. The Master Clock System itself is synchronised by a GPS (Global Positioning System) signal.



Figure 4-9: Time Synchronisation System

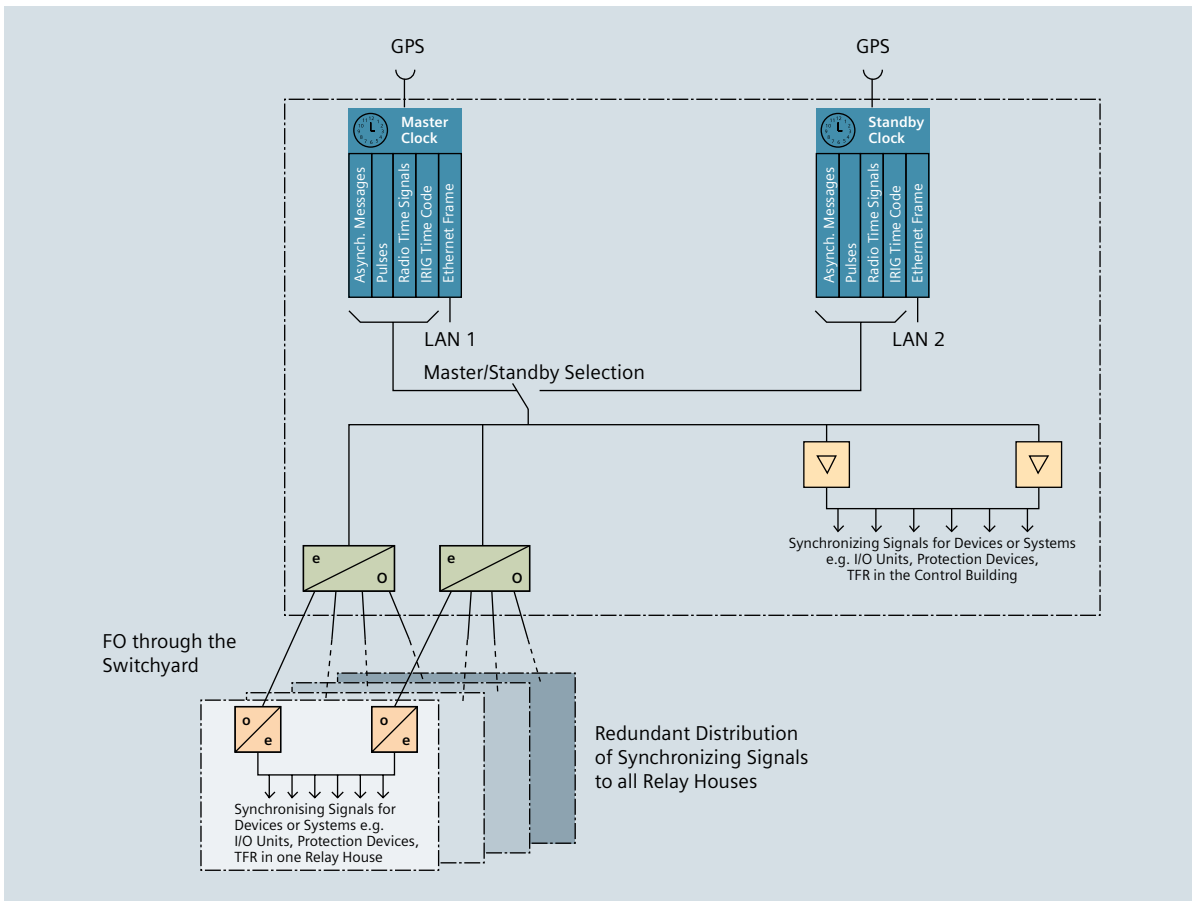

Fig. 4-8: Conceptual Overview of the Time Synchronisation

4.2.6 Remote Access

As an optional feature, the control system can be accessed from outside via ISDN lines or the Internet, see Figure 4-10. This allows plant monitoring and detection of faults – even from remote locations. To ensure data security, a VPN (Virtual Private Network)-encrypted connection is used. Furthermore, password-protected access makes sure that only authorised personnel can obtain access.

With the use of a standard web browser, main diagnosis data can be monitored. Expert access to the control components is also possible. This remote access feature provides best support for the commissioning and maintenance personnel directly from our design engineers and is a possibility to reduce the downtime of the HVDC System.

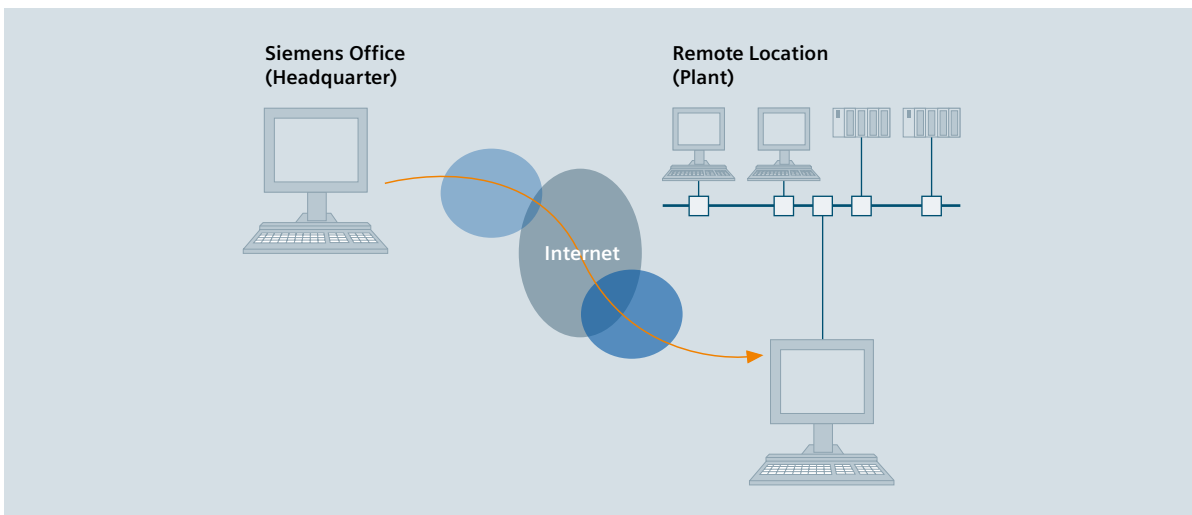

Fig. 4-10: Remote Access Connection

4.3 Control and Protection Level

The Control and Protection Level consists of the Control and Protection Systems including the respective measuring systems. The operator commands are sent to the controls, e.g. power order, bus voltage reference etc. They are executed by the closed-loop controls. Automatic converter control achieves the desired power transmission and AC bus voltage magnitude coupled with automatic switching of filters, capacitor and reactor banks.

The operator's open/close commands to the high-voltage devices are interlocked in the controls to prevent out-of-step operation of breakers, disconnectors and ground switches. Also interlocks to prevent forbidden system or switchyard configurations are installed here. Interlocking to prevent personnel access to the valve hall and filter, areas that are not walk through, is provided by means of key interlocks – controlled by the Station Controls.

The protections use the analog inputs, currents and voltages from the field level to protect the equipment. Trip commands are sent to the respective breakers, alarms are generated in the HMI's Sequence-of-Events Recorder and the Transient Fault Recorder is triggered from the protections.

Figure 4-11 shows the areas of responsibility for Station Control and Pole Control.

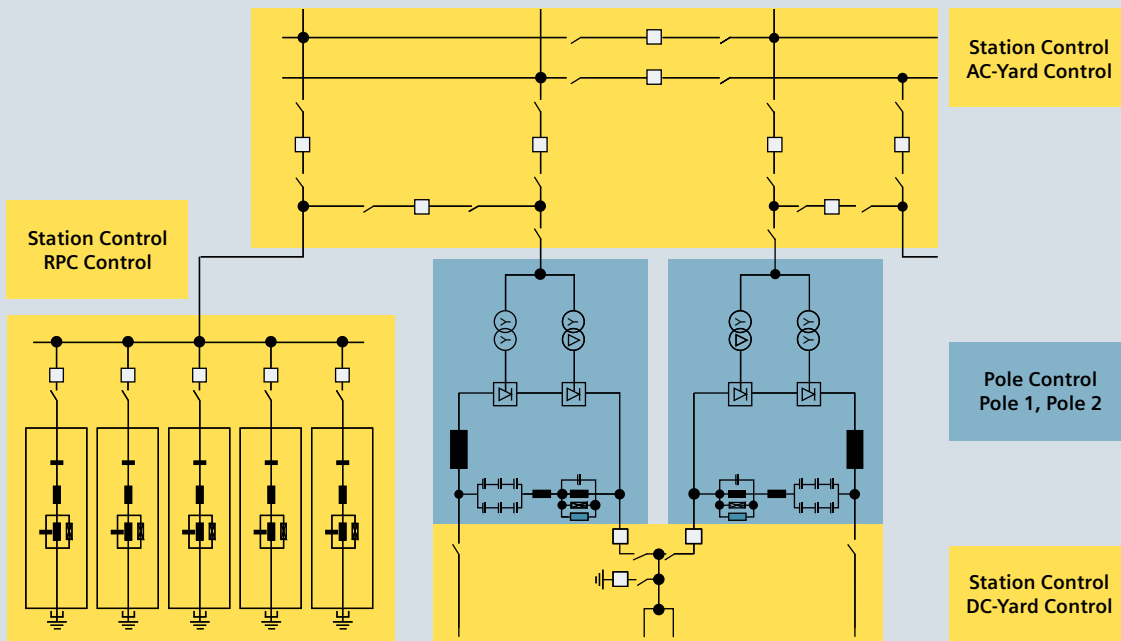

Figure 4-11: Areas of Responsibility for Station Control and Pole Control (the Figure shows one bipolar Converter Station)

4.3.1 Common HW and SW Platform for the Control and Protection Systems

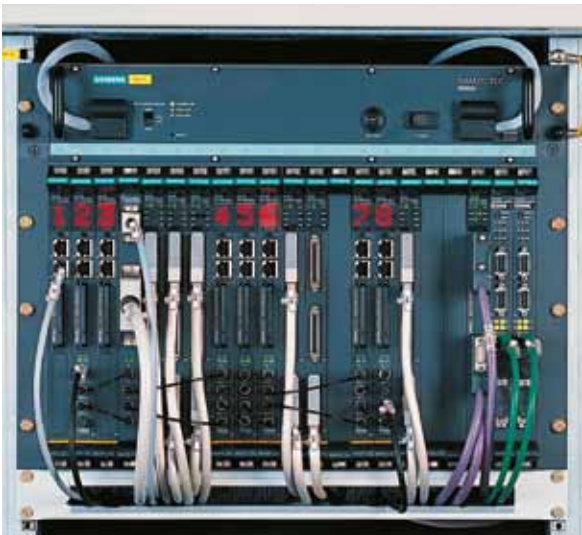

Figure 4-12: Standard SIMATIC TDC Control and Protection System

The high-performance open- and closed-loop control system SIMATIC TDC (see Figure 4-12) is used worldwide in various technologies including utility applications as well as drive systems where fast closed-loop control is also required.

SIMATIC TDC is the first controller where open and high-speed closed-loop controls can be programmed using the same programming tools and proven software. All SIMATIC TDC systems can be accessed via the MPI bus from one maintenance PC at the converter station. This represents a decisive step towards Totally Integrated Automation (TIA). The plant engineers and technicians only need to learn one programming language.

Highlights of SIMATIC TDC:

- 64 bit RISC CPU, up to 20 CPUs per rack
- I/O Boards and Communication Boards
- Industrial standard hardware design
- Graphically configurable
- More than 300 tested and well proven Standard Function Blocks

The Continuous Function Chart (CFC) is the engineering tool used to graphically configure the control functions, see Figure 4-13. The CFC uses the function blocks, which are stored in the control function library D7 SYS.

There are more than 300 function blocks as well as function blocks required for the hardware and communication stored in the D7 SYS library.

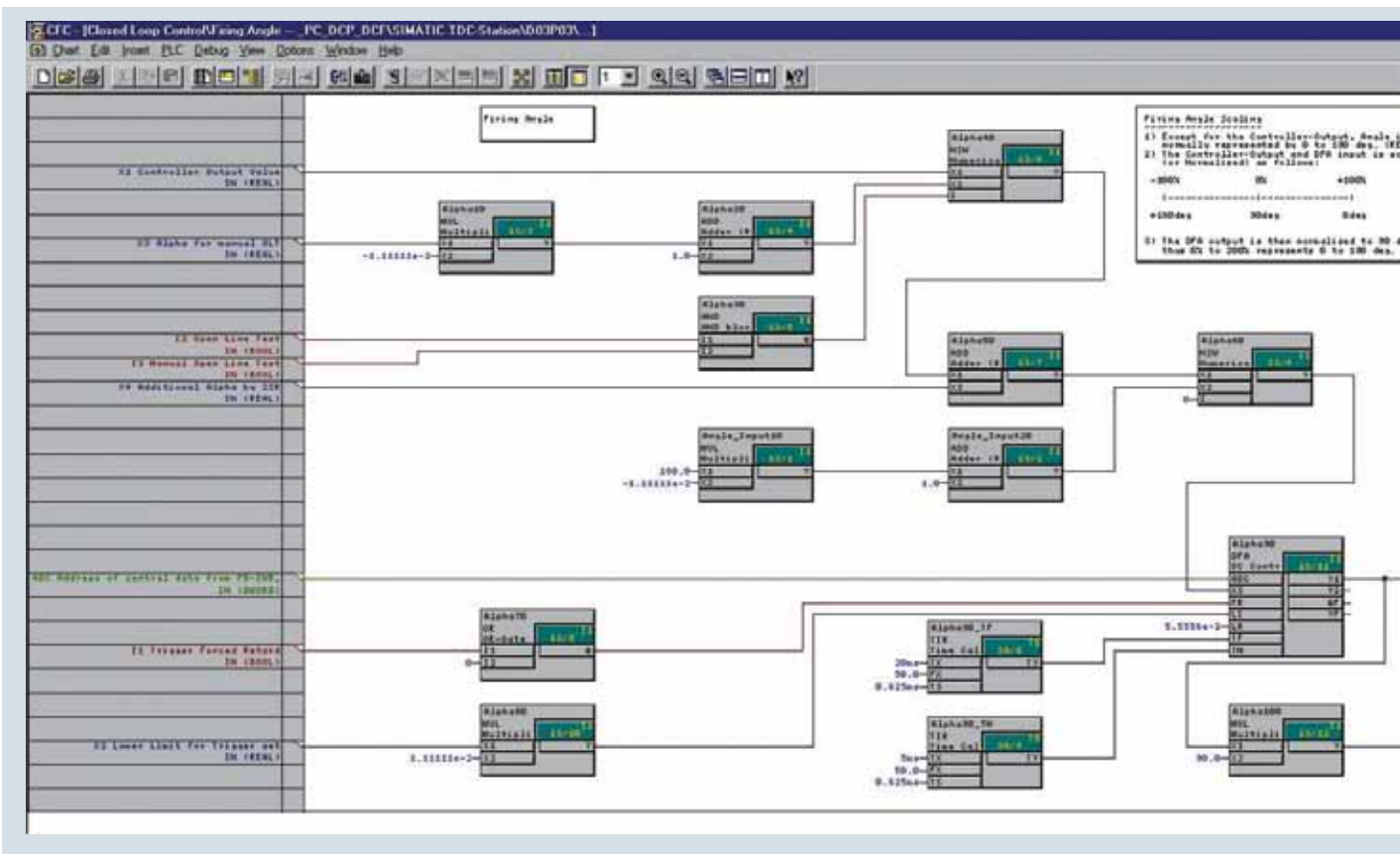

Figure 4-13: Graphical Engineering Tool CFC

4.3.2 Station Control

The Station Control manages the equipment which is necessary to integrate the HVDC System into the customer's power system and also those functions common to both poles, refer to Figure 4-11.

The main Station Control areas are:

- AC and DC Switchyard Control
- Control and monitoring of the auxiliary system
- DC Configuration Control
- Reactive Power Control
- AC Voltage Limitation Control
- Managing the control authority between different control locations

AC and DC Switchyard Control with operator guidance

The Station Control monitors and operates the high-voltage devices and handles the acquisition and the preprocessing of measured values in the AC and DC switchyards. Refer to Figure 4-14 for an overview of the interlocking philosophy.

All safety interlocking is implemented at device level as hardware or software interlocks. Station Control monitors the condition of the whole switchyards in combination with the status of the HVDC system. An additional process interlock continuously checks which preconditions have been fulfilled. Dependent on the result of these checks, the switching release for each device is defined and sent to the HMI. Only when all interlock conditions for a device have been fulfilled does the operator receive indication that device operation is possible.

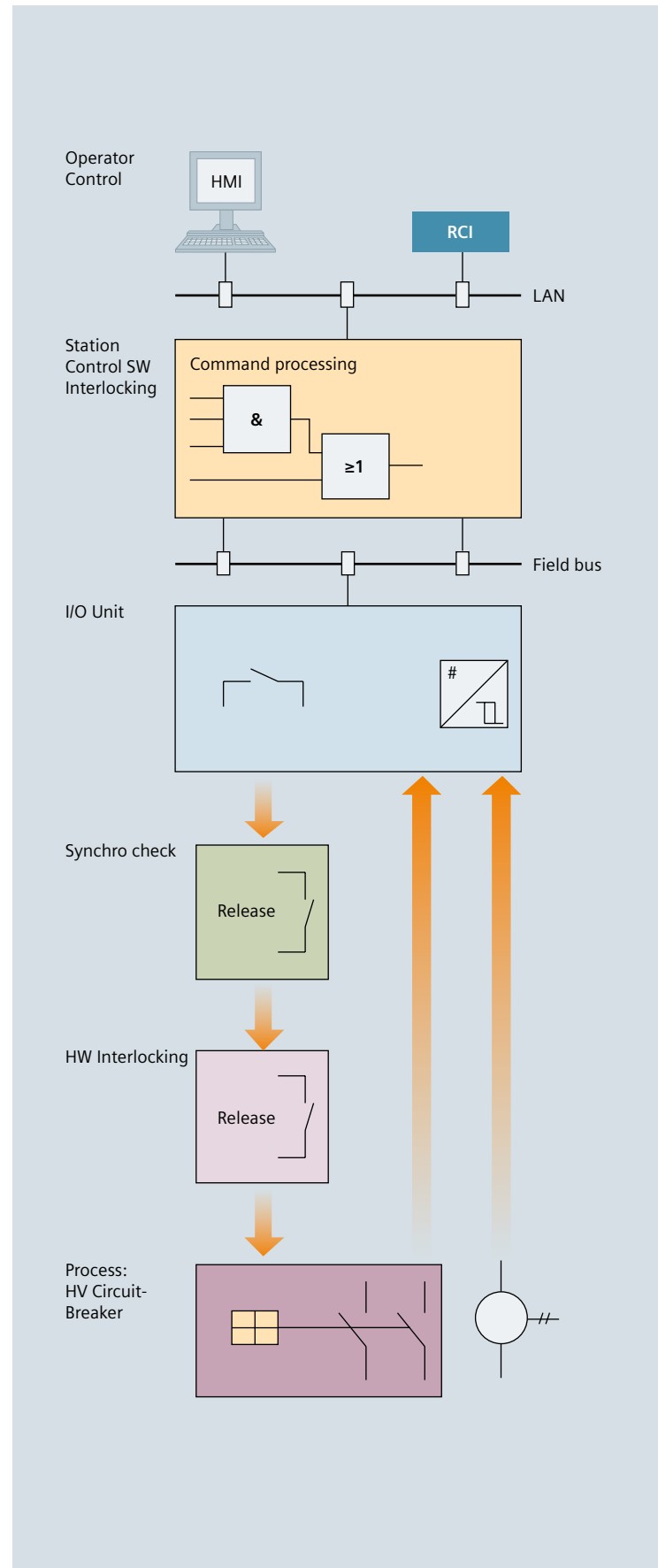

Fig. 4-14: Interlocking Philosophy

To provide a user-friendly and helpful operating environment for the Customer System, all necessary DC switchyard configurations are summarised in several states (e.g. pole 1/2 connected, metallic return selected, electrode line connected). Changing the status of the DC switchyard configuration can be easily done by the operator. After selecting the new status at the HMI, the Station Control operates the required high-voltage devices auto-matically – in the correct order. For maintenance purposes, DC switchyard control can be switched into manual mode. In manual mode the operator can initiate a switching command at the HMI for a single high-voltage device. Continuous interlock checking is always active in Manual and Automatic modes.

Reactive Power Control

The Reactive Power Control function in the Station Control automatically takes the requirements related to harmonic performance, busbar voltage and the exchange of reactive power between the HVDC system and the customer network into consideration (refer to Figure 4-15).

AC Voltage Limitation Control

Independent of Manual or Automatic control of the reactive power banks, AC voltage limitation is permanently active. Connecting further banks is inhibited if the AC voltage is above the "CONNECT INHIBIT" limit. This avoids exceeding the steady-state voltage limit and the consequent risk of trip due to AC overvoltage protection. If the AC voltage rises above the "ISOLATE" level, additional capacitor or filter banks are switched off in specified time intervals. The switch-off sequence is independent from the manual control mode of individual banks.

Transient overvoltages exceeding the specified TRIP limit result in an immediate trip of the first bank and a stepwise switching off of further banks in specified time intervals, if required by magnitude and/or duration of the overvoltage. The minimum number of AC filters remains connected to the AC busbar to enable a converter pole restart after fault clearance.

Further switching off of banks is blocked if the AC voltage drops to the "ISOLATE INHIBIT" limit and additional banks will be switched on in specified time intervals if the AC voltage reaches the "CONNECT" limit.

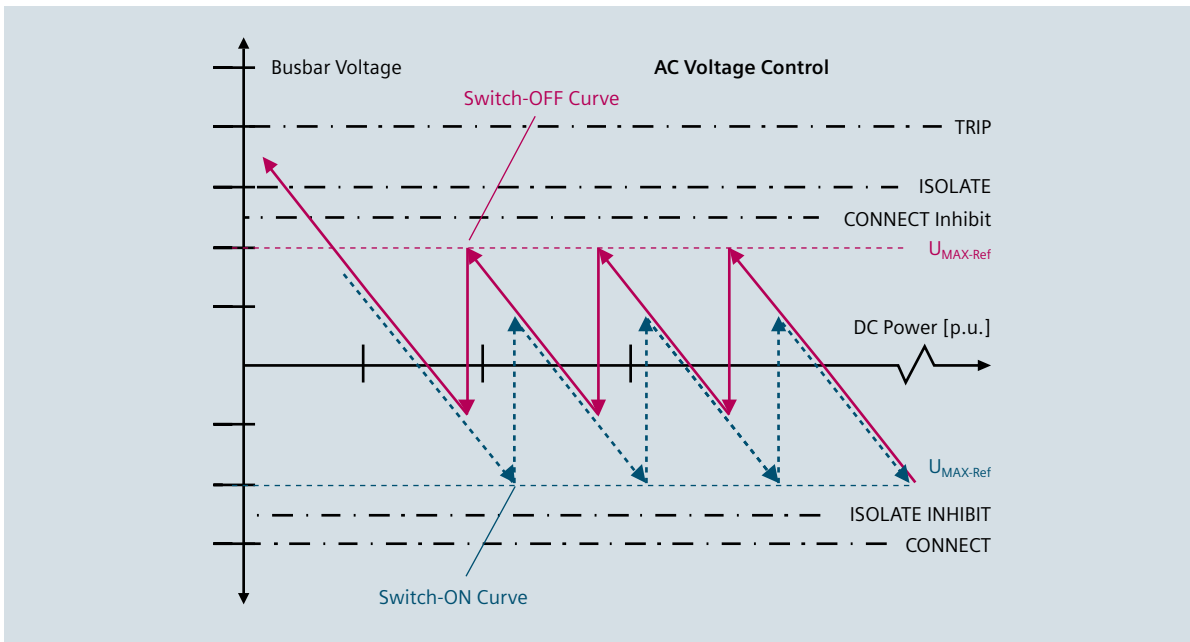

Fig. 4-15: Reactive Power – and AC Voltage Limitation Control

The operator can easily alter the reactive power flow or the range of the busbar voltage by adjusting the reference values at the HMI. Normally, automatic switching of the appropriate AC filter bank is done by the Station Control. However, the Operator can separately select each filter for manual operation – if required, for maintenance purposes. When in manual mode, the filter is no longer automatically switched but the operator can connect or disconnect it via the HMI.

Managing the Control Authority between Different Control Locations

The Siemens HVDC system can be controlled from one converter station or from a remote control centre. The Station Control manages the safe changeover of the control authority between the several control locations. Interlocks within the internal request/release software guarantee a smooth and bumpless change-over.

4.3.3 Pole Control and DC Protection

4.3.3.1 Pole Control

The Pole Controls are the heart of the HVDC control system. Here, the DC power flow is controlled to the operator's setpoint. Steady-state and dynamic performance of the AC systems is also enhanced by the Pole Controls. Features such as power swing stabilisation, frequency limit control and sub-synchronous resonance damping are some of the available features. The primary function of the Pole Control System is to maintain the transmitted power at the operator selected value. This is achieved with an optimal response during system disturbances and is robust and stable for all system configurations.

During normal undisturbed operation, DC current control is active at the Rectifier and DC voltage control at the Inverter. A backup extinction angle control provides a safety margin to minimise commutation failures at the Inverter following disturbances in its AC system. An Inverter current control function becomes active should the Rectifier station be unable to provide the ordered DC current during AC System disturbances.

Active and Reactive Power Control

The prime function of DC Power Control is to control the active steady-state Power Order selected by the operator. It must also respond to inputs from stability control functions.

Reactive Power Control is achieved by co-ordinated switching of reactive power components and firing angle control of the converter. Since filter and capacitor elements are common for the whole station, this control is located in the Station Controls. The reactive power is controlled according to minimum and maximum limits selected by the operator. Alternatively, AC Voltage Control is possible using a similar control method as used for the Reactive Power control.

DC Current and Voltage Control

DC Current Control is provided for both Rectifier and Inverter operation but used in different ways. At the Rectifier, DC Current Control is normally active controlling I_d as defined by the Power Control. At the Inverter, the current controller is a backup function and becomes active in case of abnormal conditions in the Rectifier AC system.

The task of DC Voltage Control is to maintain the DC voltage at a set value. It is used in different ways at the Rectifier and the Inverter. DC Voltage control is the normal control at the inverter and operates to control the DC voltage to the rated value. At the Rectifier, the DC voltage controller operates to limit the DC voltage to a maximum value, which is set just above the nominal converter voltage. Extinction Angle Control comes into operation automatically to prevent operation with Inverter extinction angles below a Reference Value of 17° . The Measured Value

is the smallest extinction angle of the 12 valves sampled in the previous cycle. Gamma measurement is made for each valve with an accurate measurement of the time between the end of the valve's commutation (current zero) and its respective AC voltage zero crossing.

On-Load Tap Changer Control

Different tap changer control modes are used depending on the operating configuration and the desired control modes. In one mode, the tap changer is controlled according to a firing angle reference at Rectifier (e.g. $=15^\circ \pm 2^\circ$) and extinction angle at Inverter (e.g. $=20^\circ \pm 2^\circ$). An alternative mode at both the Rectifier and Inverter side is for the tap changer to control the U_{di0} (valve side AC voltages) to the nominal value over the complete operating range of the converter. It operates to compensate for changes in AC system voltage. U_{di0} control mode is used especially in back-to-back application.

Stability Control Functions

AC systems may require transient or fixed power changes in the HVDC system to enhance their stability. Stability functions are system-dependent, the optimum control response is determined by comprehensive studies and verified with dynamic performance tests.

Power run-back and run-up functions can be provided based on inputs from the AC system. Binary signals derived from AC system state changes are used to execute a run-back or run-up. Run-backs are utilised to stabilise the AC system upon sudden loss of an infeed at the Rectifier or loss of export at the Inverter. DC power reduction can also help prevent AC system voltage instability.

Power Swing Stabilisation is a large amplitude modulation signal which is active after major AC system disturbances. Power Swing Damping is a small amplitude modulation signal which could be continuously active to provide positive damping to AC power flow in a parallel AC system or local machines. Typically, its output would be limited to ± 0.1 p.u.

Frequency Limit Control (Power Frequency Control) is a contingency control function that becomes active when the system frequency moves outside the defined frequency range. This is likely to occur in an islanded situation where the AC system has split apart. The control limits the overfrequency (and underfrequency) in the Inverter or Rectifier AC systems, but not simultaneously.

AC Voltage Limit Control is an emergency function. Of course, other control characteristics are provided to minimise the need for this function, e.g. the reactive power controller. The simplest strategy to protect the AC system from voltage drops below 0.9 p.u. is to initiate a fixed DC power reduction for a predefined AC undervoltage. Other more complex AC voltage-dependent power changes can also be implemented.

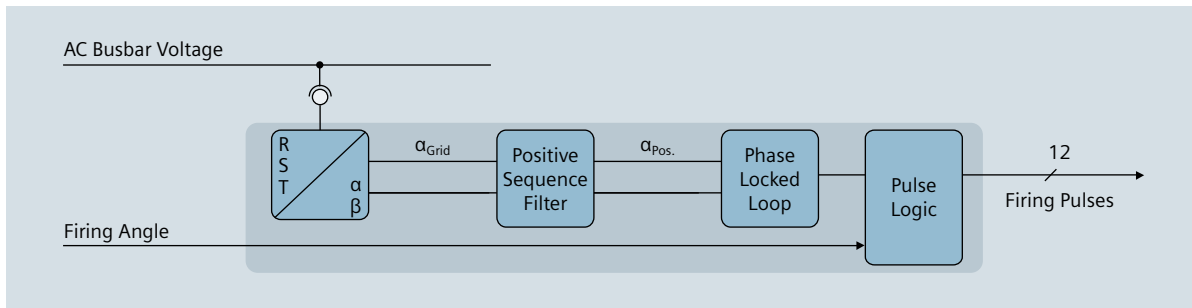

Fig. 4-16: High-Performance Firing Control System

The mechanical torsional shaft resonances of large thermal generators are typically present in the frequency range between 10 Hz and 25 Hz. Oscillations at these subsynchronous frequencies are generally excited by any contingency in the system. The current and power controllers of an HVDC interconnector may cause negative electrical damping in the frequency range where the torsional frequencies of large thermal units are present. This means that undamped torsional oscillations can be excited under certain circumstances. This is especially true when large thermal generators are directly connected to the same busbar as the HVDC system. HVDC can be used to damp the subsynchronous oscillations actively when the HVDC converter is very close to the generator. To do this, the oscillations of the shaft speed or the frequency oscillations are measured and then passed to a circuit which applies a suitable phase shift. The phase-shifted signal is then used to modulate the firing angle or the current order.

High-Performance Firing Control

The Pole Control outputs are the firing pulses for the thyristor valves, see Figure 4-16. Based on information from the Pole Controls and the AC system voltage, the trigger set generates the firing pulses. Synchronisation of the trigger set with the AC system plays an important role following major AC system disturbances. The synchronisation voltage is derived from the positive phase sequence of the AC voltages and 'tracks' any phase changes of the system fundamental frequency very quickly. During severe disturbances in the AC voltages (e.g. $U_{ac} < 0.1$ p.u.), the trigger set phase is frozen until normal voltage returns. Under balanced conditions, HVDC converters are fired equidistantly (to avoid generation of non-characteristic harmonics by the converter) and therefore it is advantageous to synchronise with the phase angle of the positive sequence component of the fundamental frequency. The equidistant accuracy for the firing control system is better than 0.01° electrical degree.

Operational States and Switching Sequences

The Pole Startup and Shutdown Sequences carry out and monitor the sequential steps for correct switching on and switching off of all pole-dedicated equipment. Four states of operation (EARTHED, STANDBY, BLOCKED and DEBLOCKED) are defined for each pole. Processing of a start or stop sequence will be activated by select-

ing a state of operation at the HMI. According to the operator guidance, the Pole Control indicates which state the pole is in. Correct execution of the sequences is checked by monitoring the time interval for each step. If the time is excessive, then the sequence will be stopped and an alarm sent to the Sequence-of-Events Recorder. After fault correction, the sequence can be continued, but if not possible, the correct steps are automatically initiated to return the pole to the previous safe state.

For long-distance transmission applications, the Open Line/Cable Test sequence provides a method for testing the voltage withstand capability of the line or cable. For this test, the DC line/cable is disconnected from the remote converter station. Then the DC voltage is slowly increased up to the maximum level via a ramp at the testing station.

Deblocking of the converter is managed by the Deblock Sequence in a coordinated manner between both stations utilising interstation telecommunication. It ensures that the Inverter is always deblocked before the Rectifier. Should interstation telecommunication be unavailable, deblocking of the converter is still possible. Both operators must coordinate deblocking via telephone to ensure that the Inverter is deblocked before the Rectifier.

The converter is blocked by the converter Block Sequence to shut down the converter with minimum disturbance to the system. It coordinates the shut down at each station and always blocks the Rectifier station first. For major faults where a protection has operated or control of the converter U_d and I_d is disturbed or lost, the Emergency Switch-Off Sequence (ESOF) shuts down the converter as quickly as possible. It also is used for any situation where AC voltage should be removed from the converter as quickly as possible.

Valve Base Electronic (VBE)

The final outputs of the Pole Control system are the thyristor firing pulses, which are sent to the VBE. Both firing pulses and End-of-Current signals (used for extinction angle measurement) are exchanged between the Pole Control and VBE. The VBE is a fault-tolerant system with self-diagnostics and on-line repair capabilities.

4.3.3.2 DC Protection

Protection Philosophy

The principal task of the protection scheme is to prevent any damage to the individual HVDC components caused by faults or overstresses. The chosen protective systems ensure that all possible faults are detected, with selective reaction and annunciation. The protection equipment is designed to be fail-safe. It incorporates comprehensive monitoring functions to provide a high degree of security. This avoids unnecessary shutdowns due to protection equipment failures. In case of defects inside the protection, the monitoring system generates an alarm and inhibits action of the faulty protection system.

DC Protection is of a fully redundant design. Additionally, both protection systems incorporate main and backup protection functions using different principles.

AC Protection also consists of a main and a backup system based on different principles. Every protection system uses different measuring devices and power supplies and is locally separated.

Main and backup protection schemes, as well as the redundant protection scheme, are both in service simultaneously and thus provide uninterrupted supervision of the AC switchyard and the HVDC plant. All protective equipment in the HVDC Converter Station will be implemented either with the digital multi-microprocessor system SIMATIC TDC or with standard numerical protective relays. The communication systems are not required for protecting the HVDC plant.

The HVDC plant is separated into different independent protection zones, refer to Figure 4-17. All zones within the HVDC system are protected with appropriate trip levels and trip times for each protected zone.

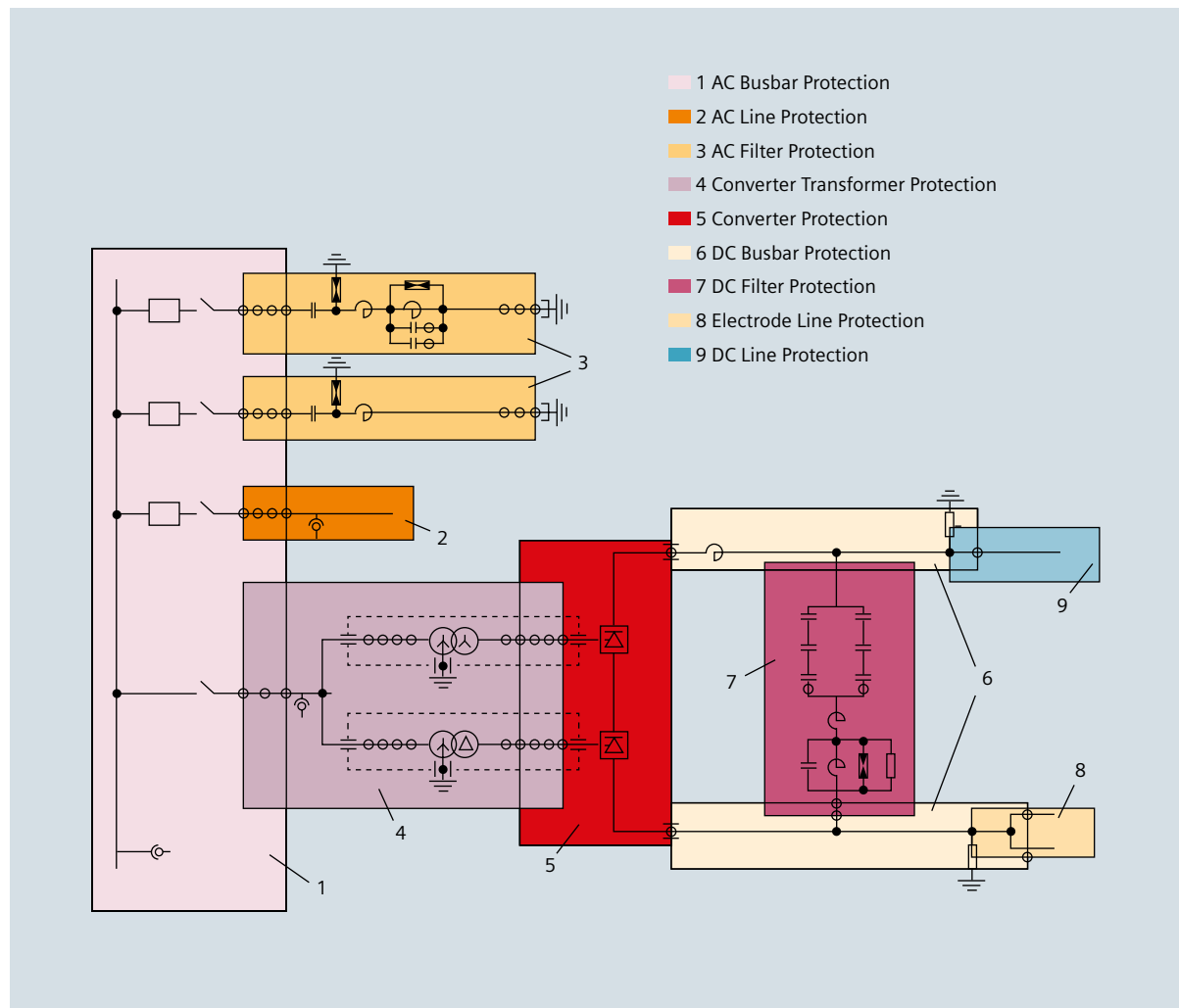

Fig. 4-17: Protection Zones for an HVDC Long-Distance Transmission Scheme

AC Busbar Protection

The AC Busbar Protection System consists of a numerical differential protection scheme. Any short circuit or ground fault within the protection zone will be detected.

AC Line Protection

The AC Line Protection consists of two protection systems. The protection preferably incorporates the following functions:

- Differential Protection
- Distance Protection

AC Filter Protection

AC Filter protection selectively detects short circuits, overcurrents, defective capacitor units and overload in the AC filter circuit. The complete protection for one AC filter bank consists of a main and a backup system. AC filter protection incorporates the following functions:

- Differential Protection
- Overcurrent Protection
- Capacitor Unbalance Protection
- Capacitor Overload Protection
- Harmonic Overload Protection
- Zero Sequence Overcurrent Protection

Converter Transformer Protection

The Converter Transformer Protection System consists of a main and a backup protection incorporating the following functions:

- Differential Protection
- Overcurrent Protection
- Thermal Overload Protection
- Ground Fault Protection
- Internal converter transformer protections (e.g. Buchholz protection)

Converter Protection

The Converter Protection detects faults on the converter transformer secondary side, in the valve hall and failures which lead to overstress of the thyristor valves. It consists of a completely redundant scheme incorporating the following functions:

- Overcurrent Protection
- Bridge Differential Protection for Wye and Delta Group
- Group Differential Protection
- Short-Circuit Protection for Wye and Delta Group
- DC Differential Protection
- DC Overvoltage Protection
- AC Overvoltage Protection

DC Busbar Protection

The DC Busbar Protection detects ground faults on the high-voltage and on the low-voltage busbar. It consists of a completely redundant scheme incorporating the following functions:

- High-Voltage DC Busbar Differential Protection
- Low-Voltage DC Busbar Differential Protection
- DC Differential Backup Protection (includes the converter)

DC Filter Protection

The DC Filter Protection detects short circuits, overcurrents and faulty capacitor units in the DC filter circuit. It consists of a completely redundant scheme incorporating the following functions:

- Differential Protection
- Overcurrent Protection
- HV Capacitor Unbalance Protection
- HV Capacitor Differential Overcurrent Protection

Electrode Line Protection

The Electrode Line Protection equipment detects earth faults, short circuits, overcurrents and open-circuit electrode lines. It consists of a completely redundant scheme incorporating the following functions:

- Current Unbalance Protection
- Overcurrent Protection
- Overvoltage Protection
- Switch Protections

In addition to these protection functions, the Siemens Pulse Echo Electrode Line Monitoring system (PEMO2000) monitors the electrode line continuously even when no power is transmitted. The PEMO2000 detects any faults in the electrode line (broken conductor and earth fault) and informs the operator about fault type and fault location.

DC Line/Cable Protection

The DC Line/Cable protection detects any ground fault at the DC Line/Cable to limit any damage and to restore operation as soon as possible. It consists of a completely redundant scheme incorporating the following functions:

- Travelling Wave Protection
- Undervoltage Detection
- DC Line/Cable Differential Protection

Harmonic Protection

A Fundamental Frequency Protection function detects 1st or 2nd harmonics in the DC current or in the DC voltage. These harmonics arise from converter misfiring or asymmetrical faults in the AC system. If the harmonic content exceeds a preset limit, then a binary signal initiates the 1st or 2nd harmonic protective action.

The Subsynchronous Resonance Protection detects resonances e.g. caused by oscillation of the power plant's generator. The resonances can be detected in the DC current. If the subsynchronous resonances exceed a preset limit, then a binary signal initiates the subsynchronous resonance protective action.

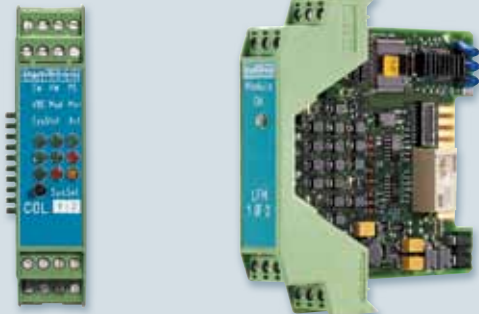

Figure 4-18: Redundancy Management

4.3.4 Redundancy Management

The Pole and Station Control Systems are designed as redundant schemes, with the redundancy management system (COL, see Figure 4-18) which is also redundant. Both redundant systems remain on-line and run in the identical operational state but only one of the controllers actively controls the process at any one time, see Figure 4-19.

This operational mode is referred to as "Hot-Standby" and this principle is advantageous where a fast changeover of controllers is necessary.

The Changeover Logic is responsible for the selection of the active control system and two Changeover Logic modules are required for each redundant system.

The first is assigned to Control System 1 and the second to Control System 2. If one Changeover Logic module fails, the Control System with the healthy Changeover Logic module automatically becomes active. In the "Automatic System Selection" mode, the Changeover Logic automatically initiates a changeover to the standby system upon fault detection in the active system. If the standby system is also faulty, the converter pole is tripped by the Changeover Logic. The active system can be selected with a pushbutton on each module. It is also possible to activate a "Manual" mode. In the "Manual" mode, the automatic changeover is disabled. This enables maintenance to be carried out on the inactive system.

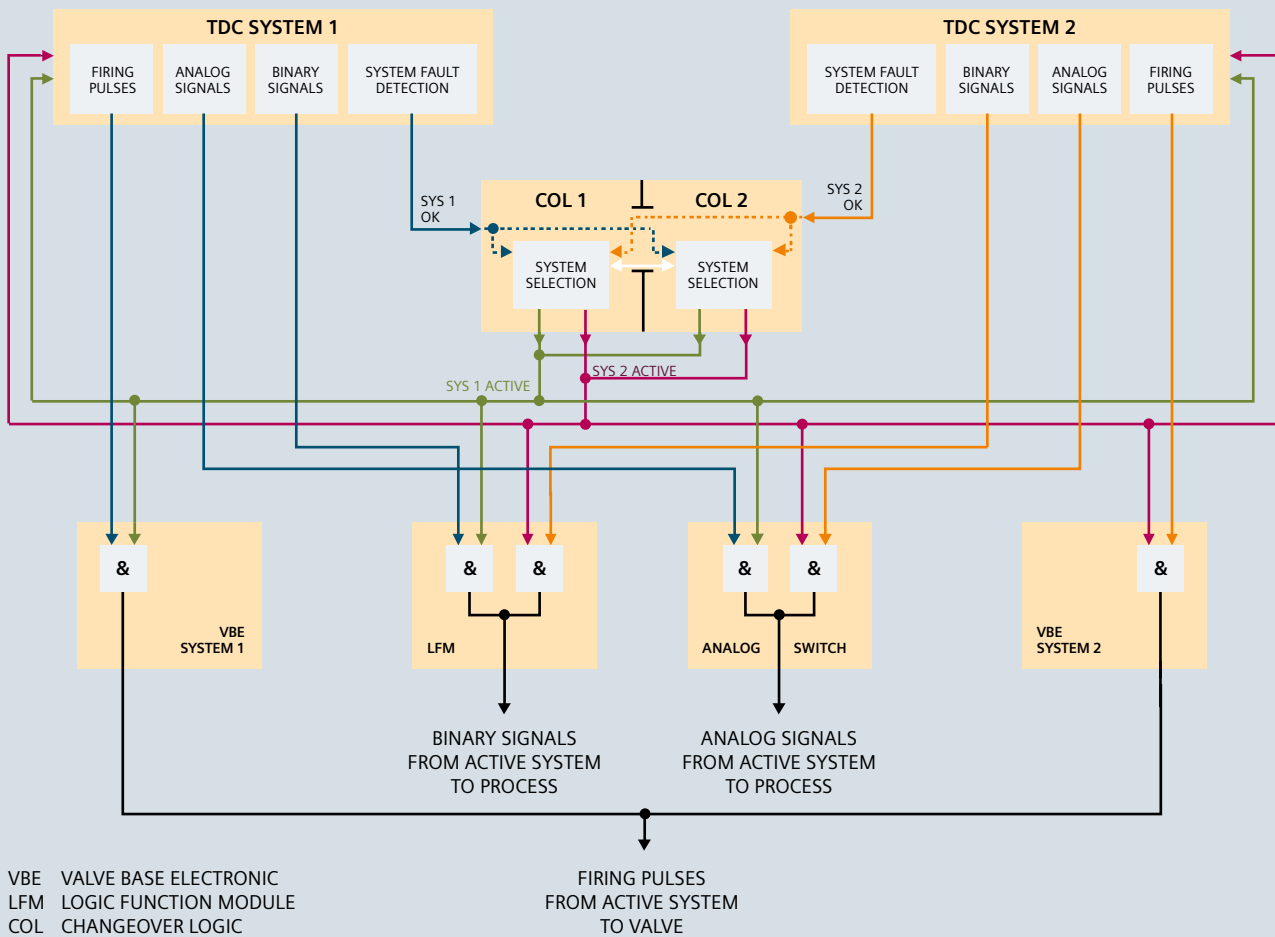

Fig. 4-19: Principle of Redundancy Management

4.3.5 Measuring System

4.3.5.1 General Concept

Redundant measuring cubicles house the optical receivers and analog inputs. The signals are multiplexed and sent to the Control and Protection via redundant optical TDM busses, see Figure 4-20. Each of the outputs of the redundant busses is connected to both of the Control and Protection Systems (Cross Redundancy). With this method, the Control and Protection redundancy can be maintained even with the loss of one measuring cubicle. Decentralised measuring is also possible, the measuring cubicle may be located in relay rooms or in the control room.

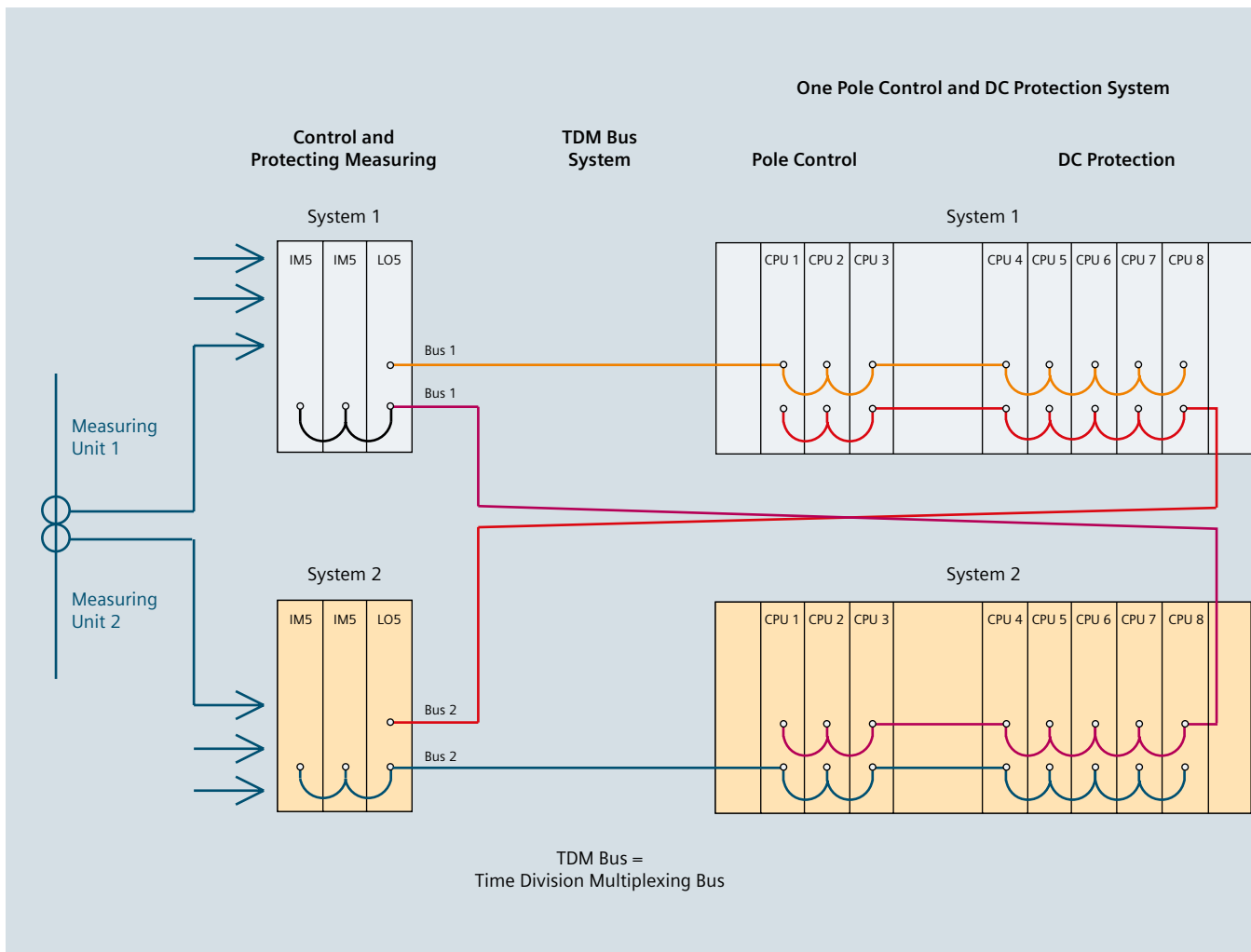

Fig. 4-20: Cross-Redundant TDM Bus

4.3.5.2 Hybrid-Optical DC Measuring

Precise and reliable measurement of both DC current and voltage is a key requirement for any HVDC system. DC currents and voltages are measured with a hybrid-optical system. DC current is sensed by measuring the voltage drop across a shunt resistor. Local "sensor head" electronics at this high voltage potential convert the voltage drop across the shunt to a serial optical signal, which is transmitted to ground potential via fibre-optic cables. The electronics are powered by laser light, which is transmitted from ground potential to the HV level by fibre optics. HV isolation is achieved with the fibre-optic cable, which is embedded in a composite insulator.

DC voltage is measured with a resistive/capacitive voltage divider. The voltage signal at ground level is transmitted to the controls using the same laser-powered electronics as used for the current measurement. The scheme is completely redundant and each Control and Protection Measuring System is totally independent, refer to Figure 4-21.

A high precision shunt rated up to 3000 A is installed in the primary circuit with a nominal voltage drop of 150 mV. The sensor heads are installed in a weather-proof box located close to the shunt at the high-voltage level. The accuracy and measuring range is selected according to the application.

The same type of sensor head electronics, fibre-optical cables and digital signal processors are also utilised for the DC voltage measuring. The DC voltage is measured with a resistive/capacitive voltage divider. The electronic sensor heads are located in the DC Voltage Divider termination box. Problems with grounding and signal voltage drop are eliminated by using the optical signal transmission.

The Optical Power Supply Module is equipped with up to 6 laser diodes. With these 6 channels, 6 sensor heads can be supplied. The Optical Receiver Module also is equipped with up to 6 optical converters and serves for evaluating the received data. Fault detection and monitoring is included. The energy fibres and signal fibres of the sensor heads are embedded in a composite insulator. This insulator provides the required insulation between the high-voltage measuring point and the ground level controls and protection. A connection box located at the bottom of the composite insulator serves as an interface. It connects the fibres of the composite insulator with the fibre-optic cables running to the Control and Protection Systems inside the control building.

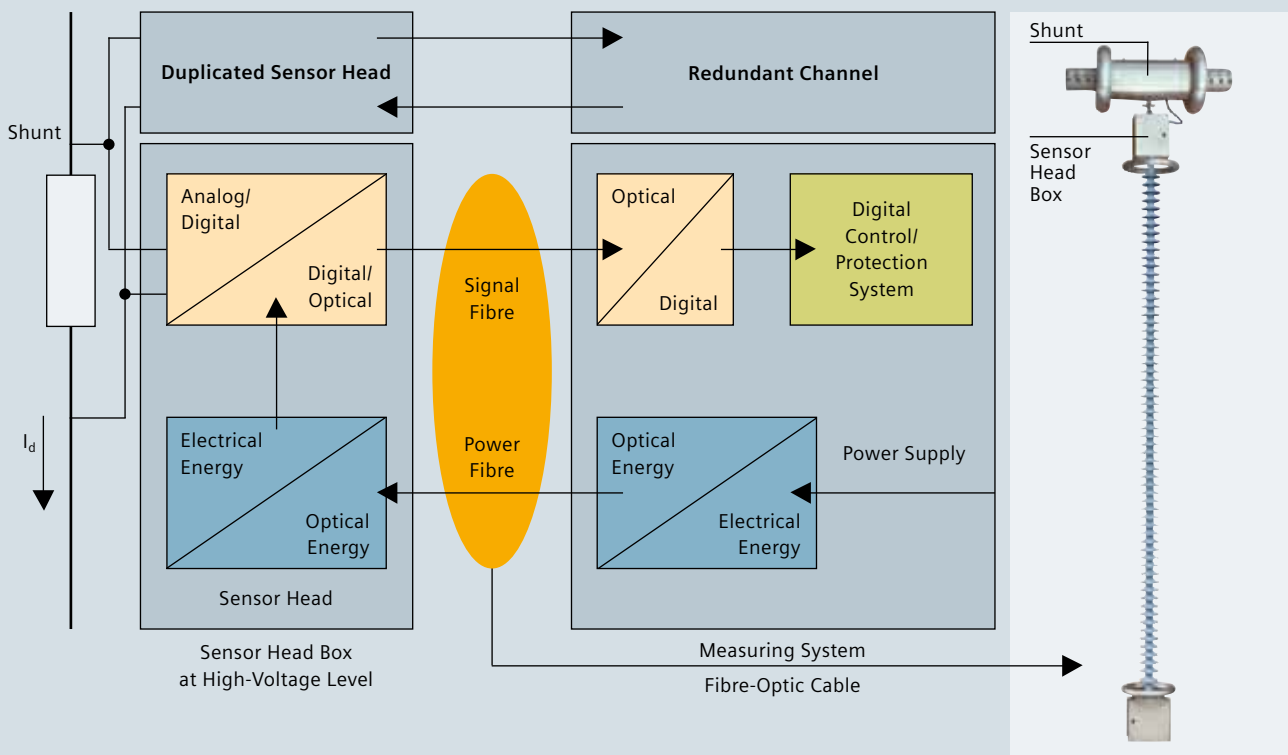

Fig. 4-21: Hybrid-Optical DC Current Measuring

4.4 Field Level

At the field level, the commands and indications of the high-voltage devices are converted to or from binary I/O signals to serial signals and connected to the field bus. In some converter stations, the switchyard bay Control and Protection is located in relay houses. This decentralised control architecture substantially reduces the cabling requirements. Input/output units which have been specially designed for switchyard applications are used to interface with the HV switchgear, see Figure 4-22. Redundant field busses are used to connect the I/O units to the redundant controls.

The lowest operating level for the high-voltage devices is manually at the breakers, disconnectors and ground switches using the Local/Off/Remote selector switch and the Open/Close pushbuttons. All remote control from the Control and Protection Level and the Operator Control Level is disabled when the device is in local operation. It is recommended that out-of-step interlocking is also be implemented at this level.

The auxiliary systems, low-voltage switchgear and diesel generators, battery chargers, UPS, air handling, valve cooling, fire detection and fire fighting are also controlled locally. Status and analog signals of the auxiliary systems are provided on the HMI's display, Sequence-of-Events Recorder and trend systems.

The converter valves are also considered to be at the field level and the Valve Base Electronic is the interface between the controls and the converter valves. Firing pulses are transmitted to the converter valves and monitoring signals are received from the converter valves.

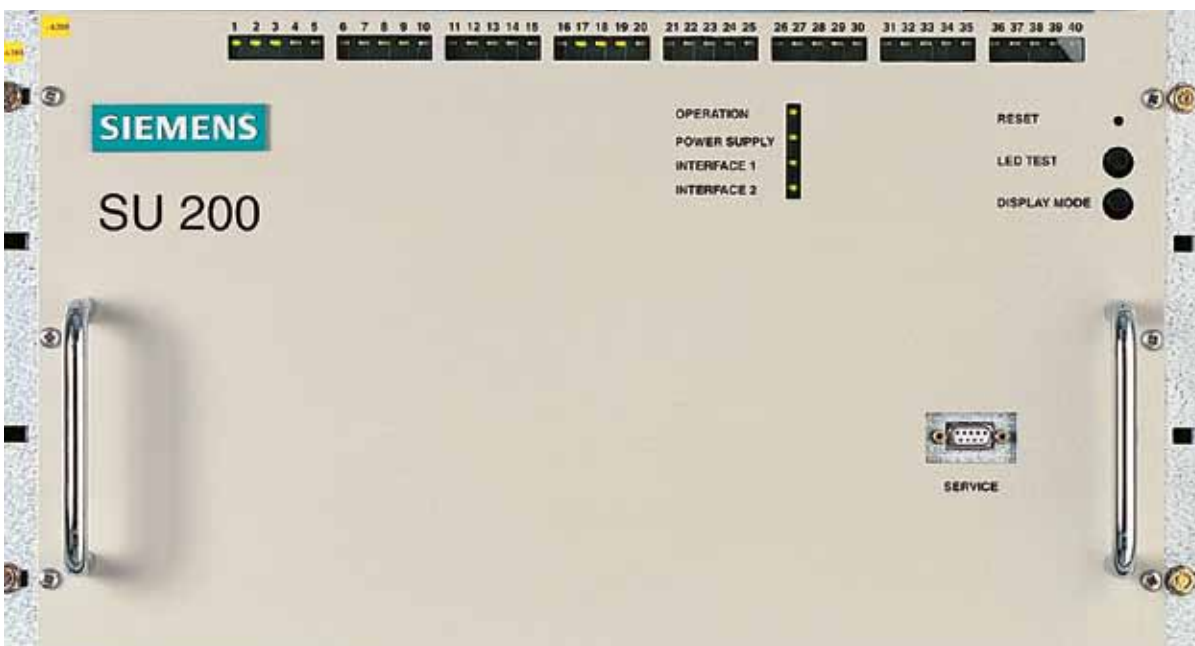

Figure 4-22: Input/Output Unit SU 200

4.5 Communication Systems

Information exchange between the Operator Control Level and the Control and Protection Level is provided by a redundant 100 Mbps Local Area Network (LAN). Information exchange between the SIMATIC TDC control systems at the Control and Protection Level and the I/O units at the Field Level is achieved via a redundant optical field bus system.

4.5.1 Lan System

The international standard of the LAN (based on switched FAST ETHERNET according to the international standard IEEE 802.3u) permits the interconnection of different types of computers. Two identical and completely separated busses exist in the redundant LAN system. Each component, which communicates via the redundant LAN system, has two interface modules, one connected to each bus so that each system can send and receive messages via both bus systems. The LAN is implemented with a double-shielded industrial twisted pair cable or fibre-optic cable up to a length of 4000 m. Figure 4-23 shows the topology of the redundant LAN at a converter station.

The electrical and the optical networks can be mixed. The advantages (e.g. high immunity to interference due to insensitivity to electromagnetic fields by the optical cables) and possible configuration (ring, star or line) of both type of networks can be used.

Data routers and data switches permit segmentation that ensure an increase in the performance. Data transmission at a rate of 10 Mbps and/or 100 Mbps is performed. Various user-oriented protocols like TCP/IP or UDP complying to the ISO/OSI reference model can be operated via the switched network. The switching technology of the optical or electrical switching module allows the structuring of Ethernet networks with large spans and large numbers of nodes. Switch module features like Autosensing and Autonegotiation allow flexible connections without any difficulty.

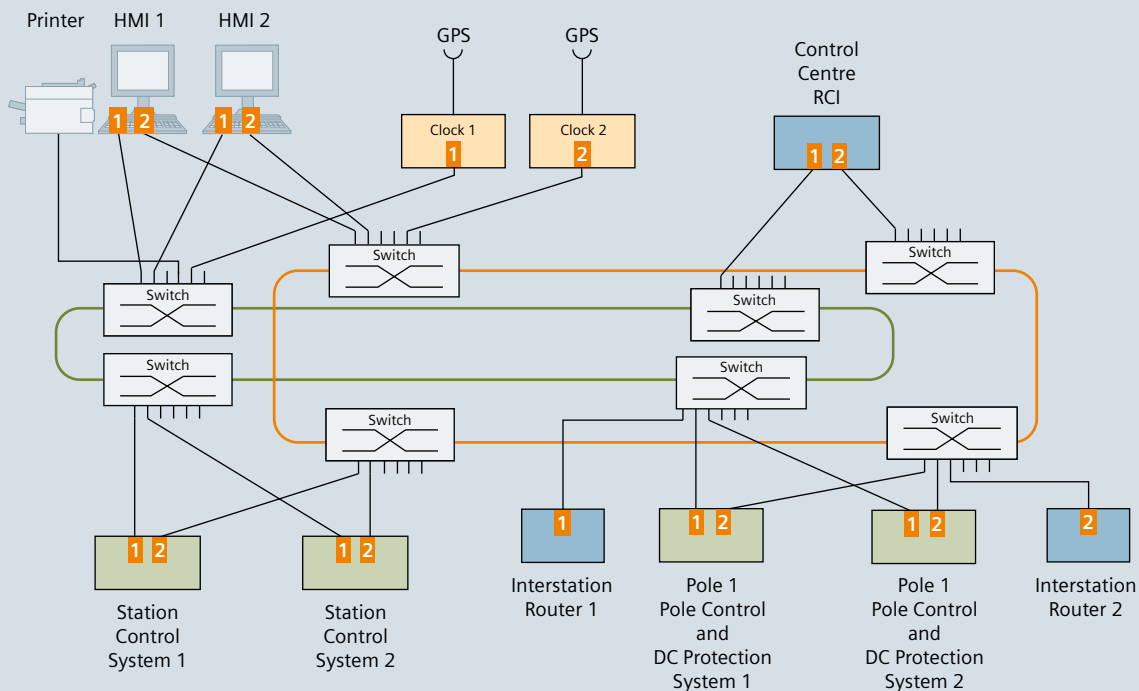

Fig. 4-23: Redundant LAN Topology

4.5.2 Field Bus System

The signal exchange between the control systems and the field devices, e.g. I/O units or protection devices, uses an optical field bus system. The field bus is in accordance with the field bus standard IEC 61158 PROFIBUS DP. PROFIBUS DP is a powerful, open and rugged bus system that permits a fast, cyclic data interchange with field devices.

The transmission medium is a double-shielded twisted pair cable or glass-fibre-optic cable. The optical fibre is insensitive to electromagnetic interference and also offers a galvanic isolation. Similar to the various LAN configurations, the topology of the field bus system also fulfils the contingency requirements, e.g. the remaining network is not disturbed in case of a single contingency transmission path fault.

4.5.3 Performance of Telecommunication Media

The exchange of data between both converter stations and between the converter station and the remote control centres can be executed through different transmission media. The data transmission media used is mainly dependent on the HVDC system application and on already existing communication installations. The most commonly used media and their related performance usually used are shown below:

Analog Power Line Carrier on AC or DC lines	up to 700 km with 2.4 kbps/channel
Digital Power Line Carrier on AC or DC lines	up to 100 km with 64 kbps/channel
Microwave	up to 70 km with 34 Mbps/channel
Fibre optic	up to several Gbps per fibre



5 Design Process, Testing Concept and Quality Assurance

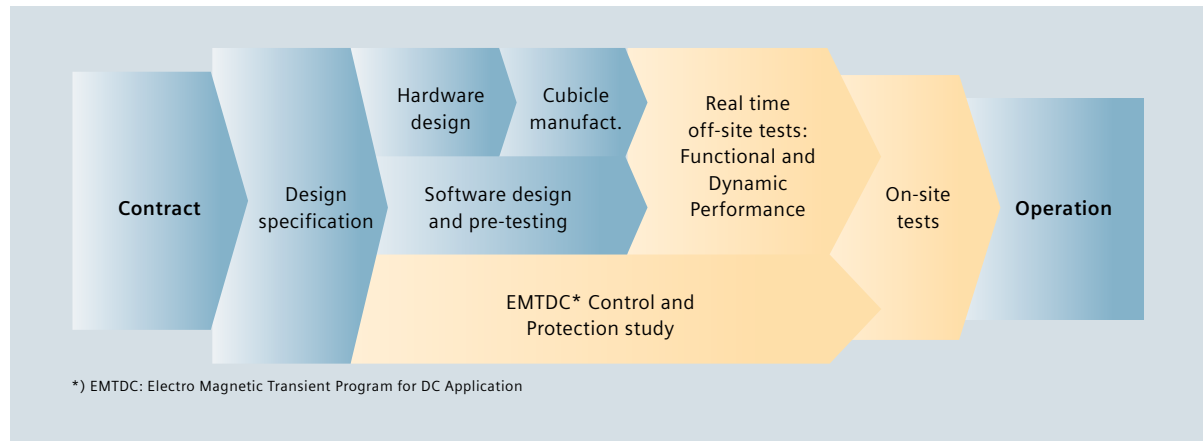

Fig. 5-1: Design Process, Testing Concept and Quality Assurance

Design Process of HVDC Control and Protection

The Design Process has a number of quality assurance review milestones at which the functionality and performance of the controls and protections are verified, see Figure 5-1. Only after successful completion of these process steps may the equipment be shipped to site.

After receiving the contract design specification, all Control and Protection functions and the related technology including cabling and testing will be provided to the customer. All steps down the engineering period and at the off-site and on-site tests are defined and documented to ensure best Quality Assurance. Within the Master Test Plan, all tests beginning with off-line tests (EMTDC), Functional Performance Tests, Dynamic Performance Tests and off-site tests are defined.

Electromagnetic Transient Program for Direct Current (EMTDC)

The Electromagnetic Transient program for DC applications (EMTDC) is a proven tool for the design of the Pole Control functions – especially the stability control functions. Within EMTDC, all relevant SIMATIC TDC function blocks are available in a control library. A detailed design of the Pole Control functions is modelled by EMTDC including the respective sampling times of each function. This capability leads to digital off-line simulation results which closely match the real behaviour of the AC/DC systems and HVDC controls. In addition to the control functions, the protection system is also represented in the digital model. This allows coordination of the Pole Control and the DC Protection.

The final structure of the control function as modelled in EMTDC can then be implemented into SIMATIC TDC. Verification of the off-line simulation is proven during the Dynamic Performance Test (DPT) and during the Functional Performance Test (FPT) where the customer's hardware and software is checked.

Functional Performance Test

In the Functional Performance Test (see Figure 5-2), the actual Control and Protection Hardware destined for site is installed and tested with a real-time simulator. The purpose of the FPT is to test the correct signal exchange between the various control components, functionality of the redundancy concept as well as the verification of the specified control sequences. This results in time-optimised on-site commissioning. Furthermore, customer personnel can participate during this test phase as part of the Operator and Maintenance Training to familiarise themselves with the control system.

Dynamic Performance Test

The simulation with EMTDC is already an extremely accurate forecast of the real system behaviour. To verify the findings, the Control and Protection Systems are tested with a Real-Time Digital Simulator (RTDS), see Figure 5-3. During this phase, the customer can witness the Performance Tests of the real Control and Protection software under different system conditions (AC Faults, DC Faults etc).



Fig. 5-3: Real-Time Simulator

On-Site Tests

On-site tests are divided into precommissioning, subsystem, station and system/acceptance tests. During the precommissioning test phase, each component is inspected and its functionality tested. This verifies that the components have not been damaged during transport or erection. The following subsystem tests prove that the individual components work together as intended. The station tests involve energisation of the primary equipment, AC switchyard, converter transformer with thyristor valves, filter banks and capacitor/reactor banks. Finally, system-acceptance tests prove that the implemented control strategies match the AC systems' requirements.

Quality Assurance

A systematic, progressive quality system ensures a longterm top competence in the field of high-voltage technology within the High Voltage Division (PTD H) of the Power Transmission and Distribution Group.

This system has been certified in conformity with DIN EN ISO 9001 since 1989 and has been integrated into the quality system implemented throughout the company in accordance with the instructions issued by the Managing Board of Siemens AG.

Our system includes all operational processes and product life cycles, from marketing right through to service and disposal. It covers all of the products and services that we offer in our capacity as a general supplier. The integration of all functions and systems into a single quality and environmental system ensures a consistently high quality standard. We therefore guarantee that our low-maintenance products will work properly and reliably for decades.



Fig. 5-2: Example for a Functional Performance Test Set-Up

7 Conclusion



Win-TDC Has Many Advantages for the End User.

- Win-TDC is a future-oriented technology for HVDC applications with an estimated product life Cycle for the next 25 years.
- The main design criteria for Siemens HVDC Systems is to achieve maximum energy availability. This principle drives the design of the Control and Protection Systems; a single equipment failure within the Control and Protection Systems may not lead to loss of system availability. Therefore, the major Control and Protection Components are configured as redundant systems.
- The SIMATIC WinCC automation software for the HMI is used throughout the automation industry worldwide. SIMATIC WinCC gives a clear and structured overview of the HVDC System for the operator, including operator guidance which prevents maloperation and explains conditions. Training for plant engineers and technicians in WinCC is available at 85 locations around the world. The HMI can easily be modified by the trained plant engineers and technicians to keep up with power system expansions or to add new control features or to generate report documents.

This large number of WinCC implementations worldwide guarantees good product and customer support. The use of standard personal computers running on a Windows operating system makes it easier to procure spares and peripheral devices.

- SIMATIC TDC, the high-performance open- and closed-loop control system is used worldwide in various technologies including utility applications as well as drive systems where fast closed-loop control is also required.
- SIMATIC TDC is the first controller where open- and closed-loop controls can be programmed using the same programming tools. This represents a decisive step towards Totally Integrated Automation (TIA). The plant engineers and technicians only need to learn one programming language. The large number of installed SIMATIC TDC systems guarantees a long life cycle and excellent customer support.
- The new Control and Protection System Win-TDC results in a much more compact design with a 50 % space reduction. Its integrated structure requires fewer components which also contributes to an overall improvement in reliability.

Published by and copyright © 2011:

Siemens AG
Energy Sector
Freyeslebenstrasse 1
91058 Erlangen, Germany

Siemens AG
Energy Sector
Power Transmission Division
Power Transmission Solutions
Freyeslebenstrasse 1
91058 Erlangen, Germany
www.siemens.com/energy/hvdc

For more information, please contact
our Customer Support Center.

Phone: +49 180/524 70 00

Fax: +49 180/524 24 71

(Charges depending on provider)

E-mail: support.energy@siemens.com

Power Transmission Division
Order No. E50001-G610-A129-X-4A00 | Printed in Germany
Dispo 30003 | c4bs No. 7805 |
TH 150-110672 | XXX | XXXXXX | PA | 0911X.X

Printed on elementary chlorine-free bleached paper.

All rights reserved.

Trademarks mentioned in this document
are the property of Siemens AG, its affiliates,
or their respective owners.

Subject to change without prior notice.

The information in this document contains general
descriptions of the technical options available, which
may not apply in all cases. The required technical
options should therefore be specified in the contract.