



SIEMENS

www.siemens.com/energy

Solutions for HVDC metering

Precise accounting of transferred energy

Answers for energy.

Are you getting what you paid for?



Your challenge:

Electricity markets are currently undergoing radical transformations. One key area of this is the increased usage of HVDC transmission systems driven by the advances in power electronics. These advances are driving greater use of DC in renewable energy generation projects, transmission across borders and other grid connectors, and across commercial boundaries. Even small losses at converter stations or over transmission lines can quickly add up to double-digit megawatts of power, with financial losses potentially in the millions. Accounting based on estimations is obviously not acceptable.

So it's only logical that the amount and quality of electricity delivered to every network boundary should be recorded precisely and at regular intervals. At the same time, it's important to detect and compensate for possible errors. And last but not least, all metering equipment must be precisely synchronized to work together perfectly – and must remain so over the long term.

Our solution:

The key to reliable DC metering is the accurate allocation of converter station and transmission losses to the true commercial boundary. This is where Siemens' DC metering solution plays a key role, using metering units located at one of the converter stations.

With the real-time evaluation of plant operation in conjunction with plant loss factors and transmission system-specific algorithms, it enables the measurement of the true power flow at the commercial boundary.

Even harsh substation environments won't affect accuracy. Backed by a proven track record, the fully industrialized DC metering solution withstands the toughest conditions.

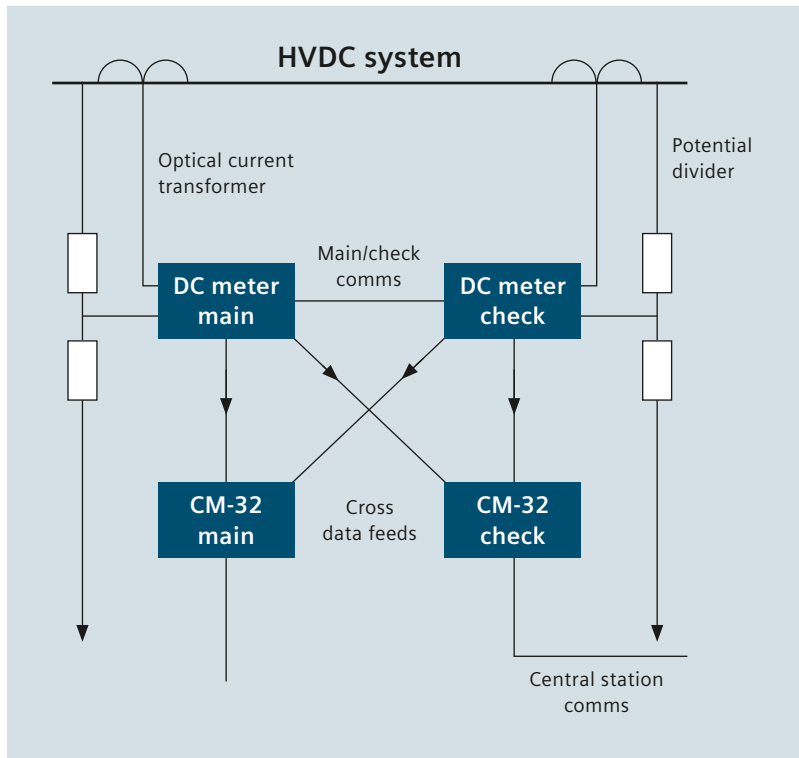

Reliability is measurable

The Siemens HVDC metering solution comprises a DC meter coupled with a CM-32 outstation. For increased confidence, main and check meters are installed along with duplicate outstations. Continuous intercomparison of readings between the two meters is used to monitor for out-of-limit data.

Precise power management

High-precision devices sample the voltage and current inputs at precisely the same time to guarantee the measurement of true power.

Error compensation

Ratio and linearity errors in the primary plant can be compensated by the meter to ensure that the highest level of accuracy is maintained throughout.

Real-time metering

In addition to the IEC 1107 configuration port, the meter is equipped with two independent serial ports giving access to real-time metering parameters including primary plant voltage, current, and power. The ports can be used to interface to substation control and SCADA systems using DNP3 (other protocols available on request).

Industry-wide compatibility

The Siemens DC metering solution is fully compatible with industry-standard data collection systems including MV90 and EnergyICT. The system can be configured to return data in 5, 10, 15, 20, or 30-minute demands.

Metering system time may be maintained and synchronized by the central data collection system or via the optional GPS clock input.

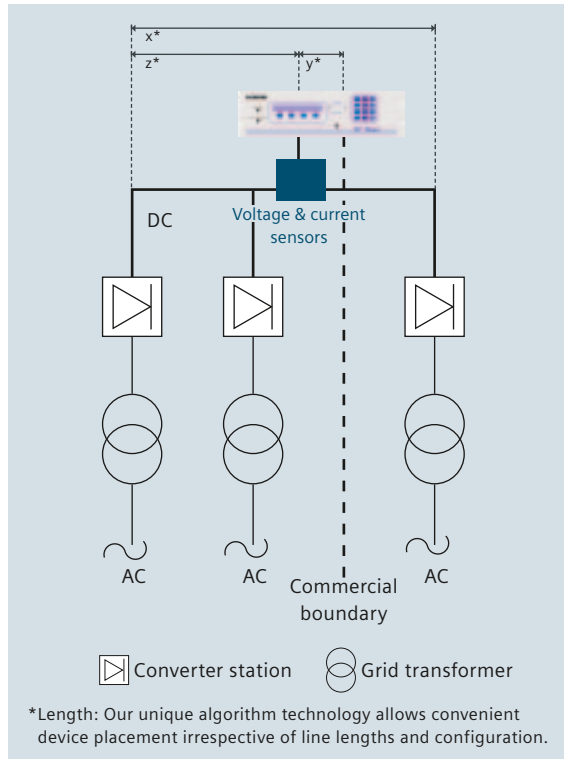

Independent function check

Plant operating mode data is included in the data collected to allow for retrospective checking of the meters' operating mode evaluation, if required. This function can be used to ensure that the correct loss factors have been applied.

Siemens Metering Services makes sure that its solutions meet the highest standards through accreditation to ISO 9001 and IEC 17025.

Value-added services and options

The DC metering solution may be supplied as a prewired, fully configured cubicle if required.

Optional TRAC software allows station operators to collect demand data from multiple DC metering systems. The data can be viewed from within TRAC, exported to spreadsheets in user-configurable formats, or exported to industry-standard energy trading systems.

Preproject consulting

In the preproject phase, Siemens can analyze any proposed metering system design, including development and evaluation of plant and cable loss algorithms. This evaluation can range from mathematical modeling to a fully customized metering system simulator.



Imagine...

... a 2-GW HVDC interconnector.
In 365 days of continuous operation
it transmits 17,520 GWh of energy.

An under- or overestimation of losses
by 0.5% amounts to 87.6 GWh, or –
assuming an average price of €70,000
per GWh – €6,132 million per annum.

From individual units to complete solutions

As a provider of comprehensive solutions, we can support you with everything from individual metering units to complete turnkey solutions. From planning to preparation and installation of metering equipment to maintenance, we manage all phases pertaining to metering. Our major-project track record and marketing leading position in a number of countries for grid metering services attest to the high quality and reliability of our solutions.

Your advantages at a glance

- Accurate revenues, thanks to more precise billing of the actual quantity of transferred energy
- Reduced need for routine maintenance, thanks to automatic reconciliation of the individual metering stations
- A complete solution from a single source, which means less time and effort for planning
- A reliable partner with outstanding references

Published by and copyright © 2011:
Siemens AG
Energy Sector
Freyeslebenstr. 1
91058 Erlangen, Germany

Siemens AG
Energy Sector
Power Distribution Division
Transmission and Distribution Services
Humboldtstr. 59
90459 Nuremberg, Germany
www.siemens.com/energy

For more information, contact our
Customer Support Center.
Phone: +49 180/524 70 00
Fax: +49 180/524 24 71
(Charges depending on provider)
E-mail: support.energy@siemens.com

Order No. E50001-G730-A218-X-4A00 | Printed in Germany |
GB 110158 PP 482385 WS 03111.0 | © 03.2011, Siemens AG

Printed on elementary chlorine-free bleached paper.

All rights reserved.

Trademarks mentioned in this document are the property
of Siemens AG, its affiliates, or their respective owners.

Subject to change without prior notice.

The information in this document contains general
descriptions of the technical options available, which
may not apply in all cases. The required technical
options should therefore be specified in the contract.