

# PSS®E

## What's new in version 32

### At a glance

PSS®E from Siemens Power Technologies International (Siemens PTI) provides users with power flow, short circuit, dynamic simulation, contingency analysis, optimal power flow, linear network, reliability assessment, and small signal analysis. The program employs the latest computer technology and numerical algorithms to provide efficient solutions for networks large and small. More than 800 different organizations worldwide are benefiting from the use of this program.

The PSS®E program package incorporates years of Siemens PTI experience and growth. The program is continuously being improved based on Siemens PTI's knowledge and experience.

### PSS®E-32 features

Version 32 includes a number of dramatic enhancements driven by customer requests, namely:

- Substation Reliability Assessment (SRA)
- Streamlined documentation
- N-1-1 contingency analysis prototype
- Enhanced integrated plotting program for dynamics simulation
- PSS®DB database
- Improved results presentation for AC contingency calculation (ACCC)
- New dynamics model for version 32
- Post-transient power flow evaluation for WECC
- Program operation improvements

### Substation Reliability Assessment

SRA is particularly suitable for:

- Comparing substation/network configuration alternatives and impacts on reliability

- Evaluating the sensitivity of substation performance to outage statistics, equipment ratings, and various load levels

Users can now specify breakers and switches within PSS®E. In addition to the traditional bus-branch models (Fig. 1), PSS®E can now represent bus-breaker models (Fig. 2).

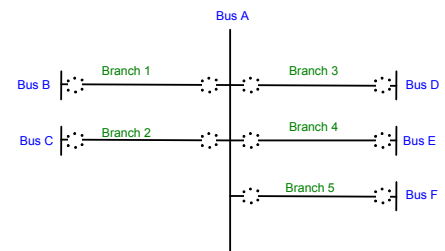

Figure 1 Bus-branch model

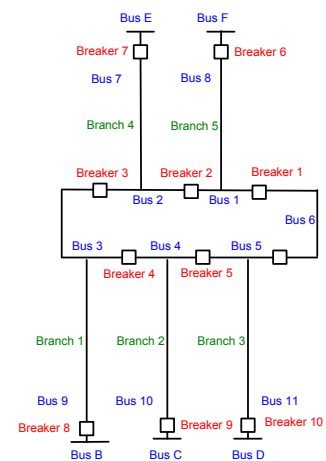

Figure 2 Bus-breaker model

- Special branch ID's and symbols are available for specifying breakers and switches in the cases and one-line diagrams
- Complex substation configuration, such as ring bus, breaker-and-a-half, etc, can now be represented in detail
- Automatic contingency analysis allows single breaker outage evaluation

Siemens PTI – Software Solutions

Answers for energy.

**SIEMENS**

## Streamlined documentation

PSS®E has over 6,000 pages of documentation to assist our users with their specific needs. From instructions on how to setup for a contingency analysis to how to model an SVC, PSS®E documentation has been providing assistance to users all over the world.

To further help users navigate our documentation, interface dependent contents were separated into an LMI guide and GUI guide to support these two modes of operation.

## N-1-1 Contingency Analysis

More stringent than N-1, but less so than N-2 (simultaneous loss of two elements), N-1-1 allows system adjustments prior to the second contingency. To comply with NERC reliability criteria, thermal or voltage violations following N-1-1 contingencies should not exist.

The existing tripping and automatic corrective actions in PSS®E are now integrated into the N-1-1 contingency evaluation.

To help our users prepare for the compliance before the standards are finalized, Version 32 provides you with a prototype Python program to evaluate system reliability compliance against N-1-1 contingency, in addition to a set of sample files to help you better understand the setup process.

## Enhanced plotting program

How would you like completing a study including steady state, short circuit, dynamics, and plotting all within the same interface?

In version 32, all these analysis components can be driven by Python in the single entry program point. Additionally, the plotting package has been expanded to include the most commonly used features such as time plot, X-Y plot, and arithmetic functions. Templates of frequently used stability plots are also provided.

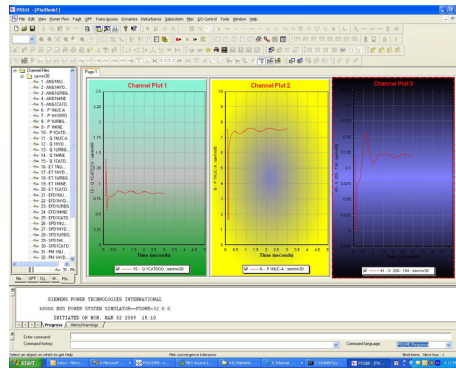

Figure 3 Plotting

## PSS®DB database

A personal, open database (Microsoft® Access or SQL) that works with PSS®E save cases and raw data files is available. Use variants to streamline your process in:

- Option evaluation of network upgrade
- Assessment of various load levels in the planning horizons

Additional tools, such as harmonics module and protection module, are also available.

## Improved ACCC results presentation

Contingencies can be ranked according to several methodologies and examined at the post-contingency, post-tripping and post-corrective actions stages by using previous and next buttons. Results can be displayed on the Slider Diagram as numbers or as a contour, allowing easy identification of elements causing problems.

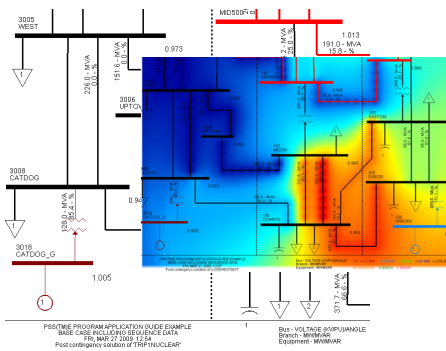

Figure 4 ACCC

## New dynamics models for version 32

- Generic two-terminal DC line model – CDC7T
- New IEEE 421.5 models – ST5B, UEL1, ST7B, PSS4B, DC3A, and PSS1A
- Generic wind models

## Post-transient power flow evaluation for WECC

WECC\_Ptran\_2PV\_IPP.py is a program that will create post-transient power flow outage cases to be used for conducting transmission rating studies in the post-transient environment.

This program enables the user to control how a base case is adjusted for the outage modeled. This is accomplished through an input file created by the user. This program was created for studies in the WECC region but can be manipulated by the user to fit other criteria.

## Program operation improvements

- Elimination of working files and automatic resizing of bus limits when larger networks are loaded
- Integrated command line and improved character default handling
- Full four-digit representation for Areas, Owners, and Zones
- Added support for international number formats to spreadsheets
- Contingency file enhancements
- Improved switched shunt modeling and status flags
- Integrated command line

Published by and copyright © 2009:  
Siemens AG  
Energy Sector  
E D SE PTI  
Freyeslebenstrasse 1  
91058 Erlangen, Germany

www.siemens.com/power-technologies

Siemens Energy, Inc.  
Power Distribution, T&D Service Solutions  
Siemens Power Technologies International  
400 State Street  
PO Box 1058  
Schenectady, NY 12301-1058

Siemens Transmission and Distribution Ltd  
Siemens PTI  
Sir William Siemens House, Princess Road  
Manchester, M20 2UR  
United Kingdom

For more information, please contact  
our Customer Support Center.  
Phone: +49 180 524 70 00  
Fax: +49 180 524 24 71  
(Charges depending on provider)  
E-mail: support.energy@siemens.com

Power Distribution Division  
Printed in Germany  
Printed on elementary chlorine-free  
bleached paper.

All rights reserved.  
Trademarks mentioned in this document  
are the property of Siemens AG, its affiliates,  
or their respective owners.  
Subject to change without prior notice.  
The information in this document contains general  
descriptions of the technical options available,  
which may not apply in all cases.  
The required technical options should therefore be  
specified in the contract.

SWPE01-EN-200904