



PSS[®]E

IEC 60909 Fault Calculations

IEC 60909 Fault Calculations (IECS)

- Easy to setup,
- Fast solution,
- Multiple ways to initiate calculations and report results,
- Meet IEC 60909-2001 standard requirements

At a glance

PSS[®]E Version 31 performs IEC 60909 based fault analysis in addition to its other well known suite of fault analyses capabilities. This new fault calculation methodology is a self-contained analysis within PSS[®]E. The single requirement prior to entering the IECS fault calculation method is a valid power flow working case. The system sequence data is required only if unsymmetrical faults are to be simulated. It simulates all fault types specified in IEC 60909, namely:

- three-phase (3PH) faults
- single-line-to-ground (LG) faults
- double line-to-ground (LLG) faults
- line-to-line (LL) faults

It can simulate one or all fault types at one bus or all system or sub-system buses in one run thereby reducing the analysis time.

The challenge

The electrical utilities and industries need to design, operate, protect and maintain the electrical installations as per IEC fault current duties. To determine the worst fault duties, one needs to consider various types of faults and number of network scenarios potentially leading to a large number of short circuit calculations. Assembling and validating the vast electrical network data required for fault analyses is cumbersome and time consuming.

Our solution

IEC fault calculation uses existing PSS[®]E power flow and sequence network data. No additional validation of such data is required. All fault currents are calculated per IEC 60909 standard and the currents calculated include:

- I''_k Initial RMS symmetrical short-circuit current
- $i_p(B)$ Peak short-circuit current by IEC 60909 Method B
- $i_p(C)$ Peak short-circuit current by IEC 60909 Method C
- i_b (DC) DC component of asymmetrical breaking current
- i_b (SYM) RMS Symmetrical short-circuit breaking current
- i_b (ASYM) RMS Asymmetrical short-circuit breaking current

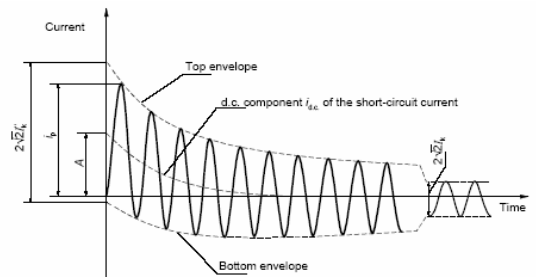

- I''_k = initial symmetrical short-circuit current
- i_p = peak short-circuit current
- I_k = steady-state short-circuit current
- i_{dc} = d.c. component of short-circuit current
- A = initial value of the d.c. component i_{dc}

The various network elements, i.e., generators, motors, transformers, power station units, loads, shunts, and dc devices are treated as per the IEC 60909 standard.

Siemens PTI – Software Solutions

Answers for energy.

SIEMENS

The fault calculations can be launched from PSS®E GUI; PSS®E batch scripts (BAT_, Python, IDEV) to simulate one or all faults at one or all buses in one run, without requiring additional commands.



Figure 2 IEC 60909 Fault Calculation Dialog

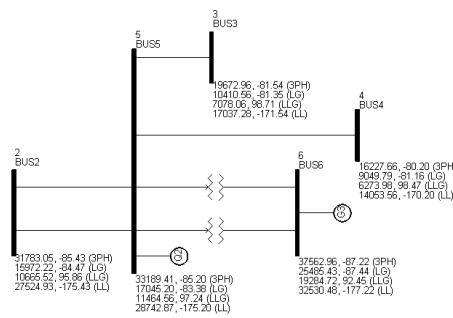

Reports presenting “Total Fault Currents” and “Fault Currents Contributions” at N levels away from the faulted bus are available. Fault currents and voltages (Ia1, Ia2, Ia0, IA, IB, IC, Va1, Va2, Va0, VA, VB, VC) can also be displayed on network model one line diagrams or exported to Python lists.

Application example

Results show the comparison of short circuit currents obtained from PSS®E IEC fault calculations and results given in IEC 60909-4, 2001 standard Sections 6.3.1 and 6.3.2.

Solution Method	Faulted Bus	3PH Fault	LG Fault
		I_k kA	I_k kA
standard	1	40.6447	
PSS®E		40.6447	
standard	2	31.7831	15.9722
PSS®E		31.7831	15.9722
standard	3	19.6730	10.4106
PSS®E		19.6730	10.4106
standard	4	16.2277	9.0498
PSS®E		16.2277	9.0498
standard	5	33.1894	17.0452
PSS®E		33.1894	17.0452
standard	6	37.5629	
PSS®E		37.5630	
standard	7	25.5895	
PSS®E		25.5896	
standard	8	13.5778	
PSS®E		13.5778	

Published by and copyright © 2009:
Siemens Energy, Inc.
Power Distribution, T&D Service Solutions
Siemens Power Technologies International
400 State Street
PO Box 1058
Schenectady, NY 12301-1058
www.siemens.com/energy/power-technologies

Siemens AG
Energy Sector
E D SE PTI
Freyeslebenstrasse 1
91058 Erlangen, Germany
Siemens Transmission and Distribution Ltd
PTI
Sir William Siemens House, Princess Road
Manchester, M20 2UR
United Kingdom

For more information, please contact our Customer Support Center.
Phone: +49 180 524 70 00
Fax: +49 180 524 24 71
(Charges depending on provider)
E-mail: support.energy@siemens.com
Power Distribution Division
Printed in Germany
Printed on elementary chlorine-free bleached paper.

All rights reserved. Trademarks mentioned in this document are the property of Siemens AG, its affiliates, or their respective owners. Subject to change without prior notice. The information in this document contains general descriptions of the technical options available, which may not apply in all cases. The required technical options should therefore be specified in the contract.

SWPE06-EN-200905