



Bypass switches

Type B-1 and type B-2

Answers for energy.

SIEMENS



Eliminate voltage regulator bypass switch problems with type B-1 and type B-2



Overview **Type B-1**

The Bridges Electric™ type B-1 regulator bypass switch is a simple and rugged three-bladed disconnect switch. Each blade is independently operated and is readily visible to the operator. The major safety feature of the type B-1 is that the bypass blade can be visually checked to ensure that it is open. This helps eliminate the possibility of the regulator being short-circuited when it is restored to service. Many available options and accessories make the type B-1 a flexible solution for regulator bypass schemes.

Type B-2

The Bridges Electric type B-2 oil circuit recloser (O.C.R.) (or regulator) bypass switch utilizes the same blade and contact material as the type B-1. Its design provides clearance for an O.C.R. bypass scheme, but can be used as a regulator bypass. Versatility is provided with optional backplate sets for underhung mounting or an angled pole bracket for mounting directly to the pole. Many available options and accessories make the type B-2 a flexible solution for O.C.R. and regulator bypass schemes.



Details

Type B-1 regulator bypass: 600 A

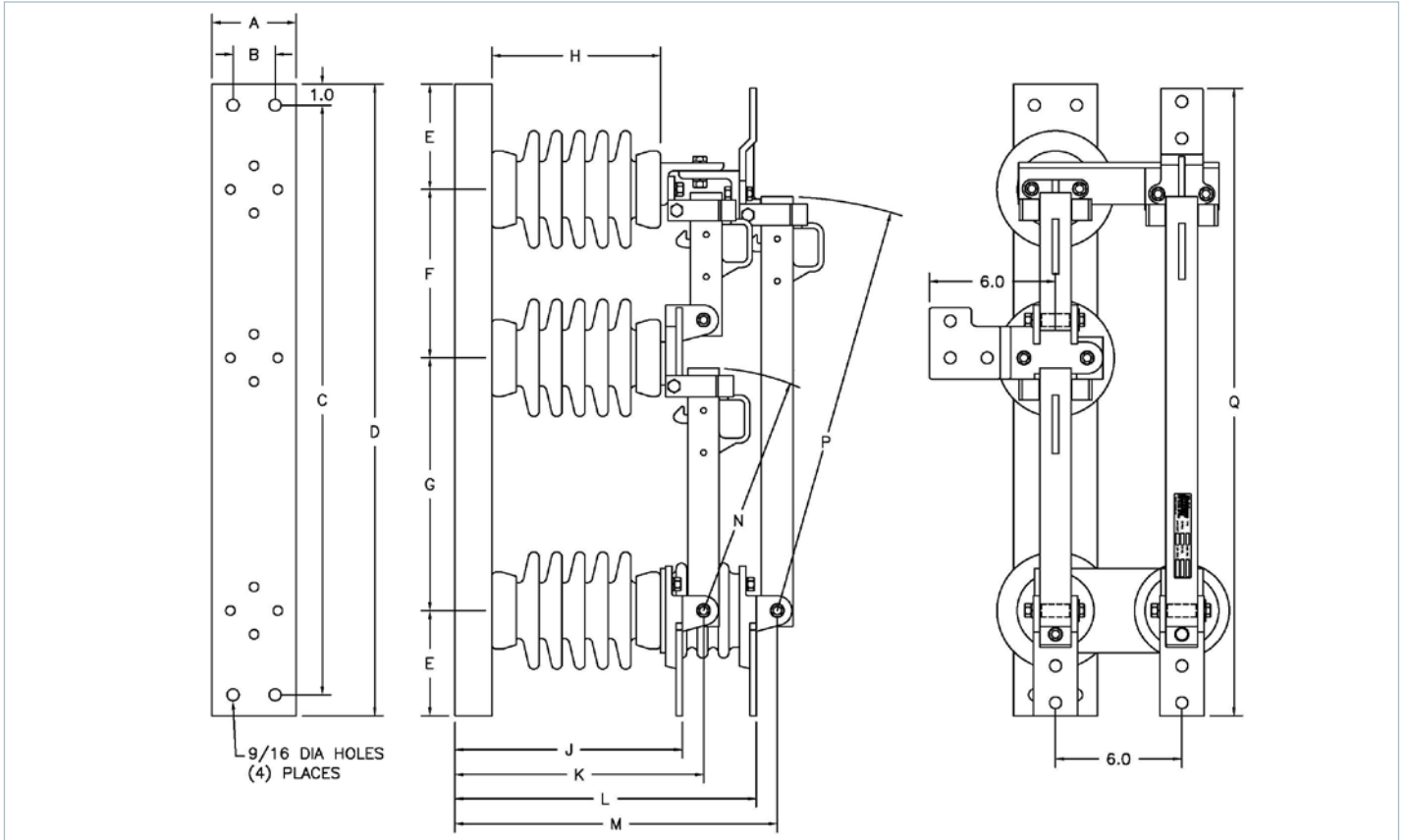

Cat. no.	Rating data					Dimensions - inches															Insulators
	NOM kV	MAX kV	kV BIL	Amps		A	B	C	D	E	F	G	H	J	K	L	M	N	P	Q	
610	14.4	15	110	600	40,000	4	2	28	30	5	8	12	8	10.8	11.8	14.3	15.3	11.5	19.7	29.7	2 1/4" D.B.C.
710	23	25	150	600	40,000	4	2	31	33	5	10	15	10	12.8	13.8	16.3	17.3	14.5	22.7	32.7	
615	14.4	15	110	600	40,000	4	2	31	33	5	10	15	10	12.8	13.8	16.3	17.3	14.5	22.7	32.7	3" D.B.C.
715	23	25	150	600	40,000	4	2	34	36	5	14	18	14	16.8	17.8	20.3	21.3	17.5	25.7	35.7	
815	34.5	38	200	600	40,000	6	2	40	42	5	18	24	18	20.8	21.8	20.3	21.3	23.5	31.7	41.7	

Note: Add these suffixes to catalog numbers for the option described

C = Polymer insulator

H = Loadbreak hooks

K = Cable connector

#6 - 397.5 MCM ACSR

#6 - 500 MCM copper

P = Pole mount bracket

QB = Quick break

T = Tinned terminal pads

X = Backplate set

Example: "610CQBT = type B-1, 15 kV, 110 kV BIL, 600 A, polymer insulators, quick break, tinned terminal pads"

Details

Type B-1 regulator bypass: 900 A

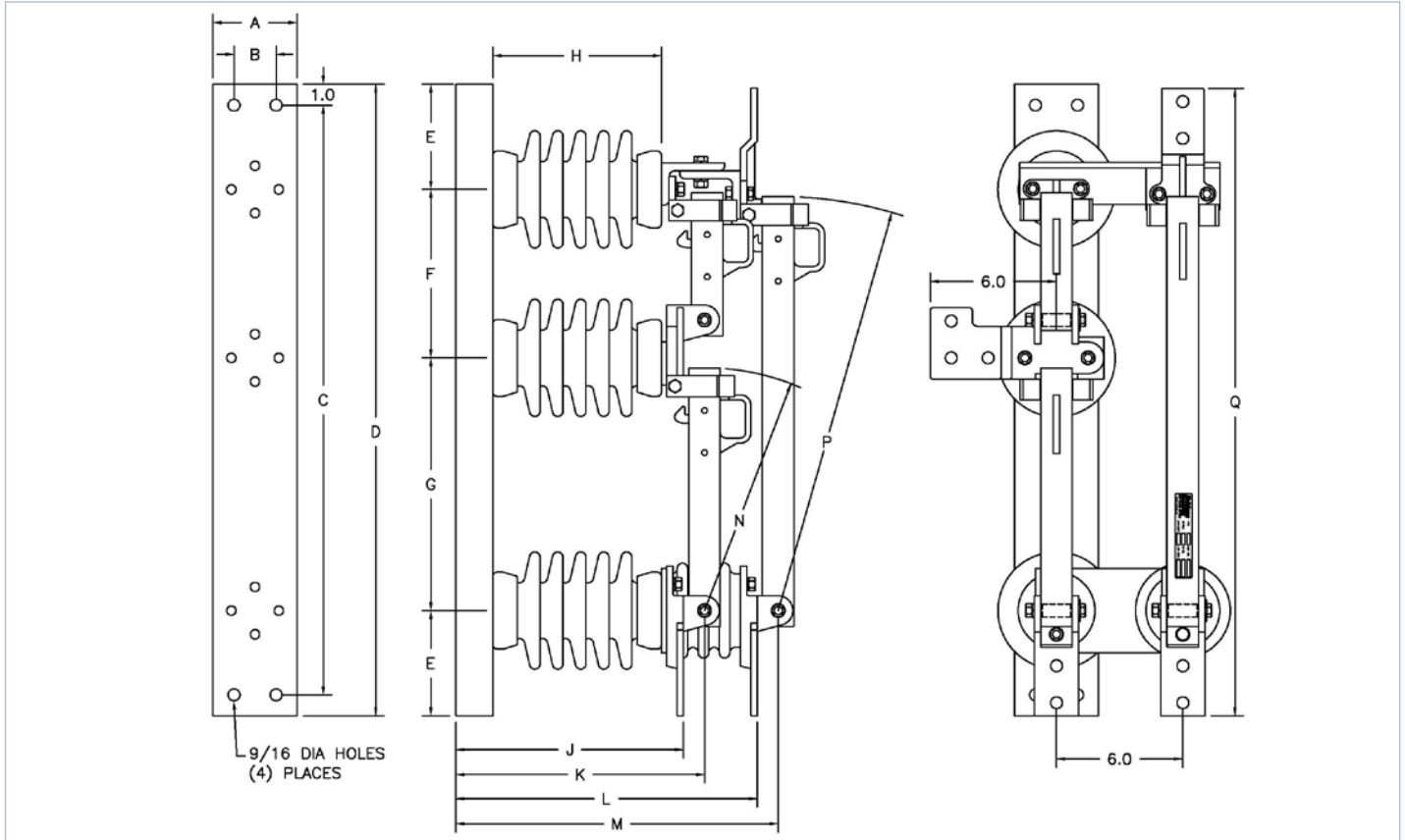

Cat. no.	Rating data				Dimensions - inches																Insulators
	NOM kV	MAX kV	kV BIL	Amps		A	B	C	D	E	F	G	H	J	K	L	M	N	P	Q	
630	14.4	15	110	900	40,000	4	2	28	30	5	8	12	8	10.8	11.8	14.3	15.3	11.5	19.7	29.7	2 1/4" D.B.C.
730	23	25	150	900	40,000	4	2	31	33	5	10	15	10	12.8	13.8	16.3	17.3	14.5	22.7	32.7	
635	14.4	15	110	900	40,000	4	2	31	33	5	10	15	10	12.8	13.8	16.3	17.3	14.5	22.7	32.7	3" D.B.C.
735	23	25	150	900	40,000	4	2	34	36	5	14	18	14	16.8	17.8	20.3	21.3	17.5	25.7	35.7	
835	34.5	38	200	900	40,000	6	2	40	42	5	18	24	18	20.8	21.8	20.3	21.3	23.5	31.7	41.7	

Note: Add these suffixes to catalog numbers for the option described

- C = Polymer insulator
- H = Loadbreak hooks
- K = Cable connector
- #6 - 397.5 MCM ACSR
- #6 - 500 MCM copper
- P = Pole mount bracket
- QB = Quick break

T = Tinned terminal pads

X = Backplate set

Example: "630CQBT = Type B-1, 15 kV, 110 kV BIL, 900 A, polymer insulators, quick break, tinned terminal pads"

Details

Type B-1 regulator bypass: 1,200 A

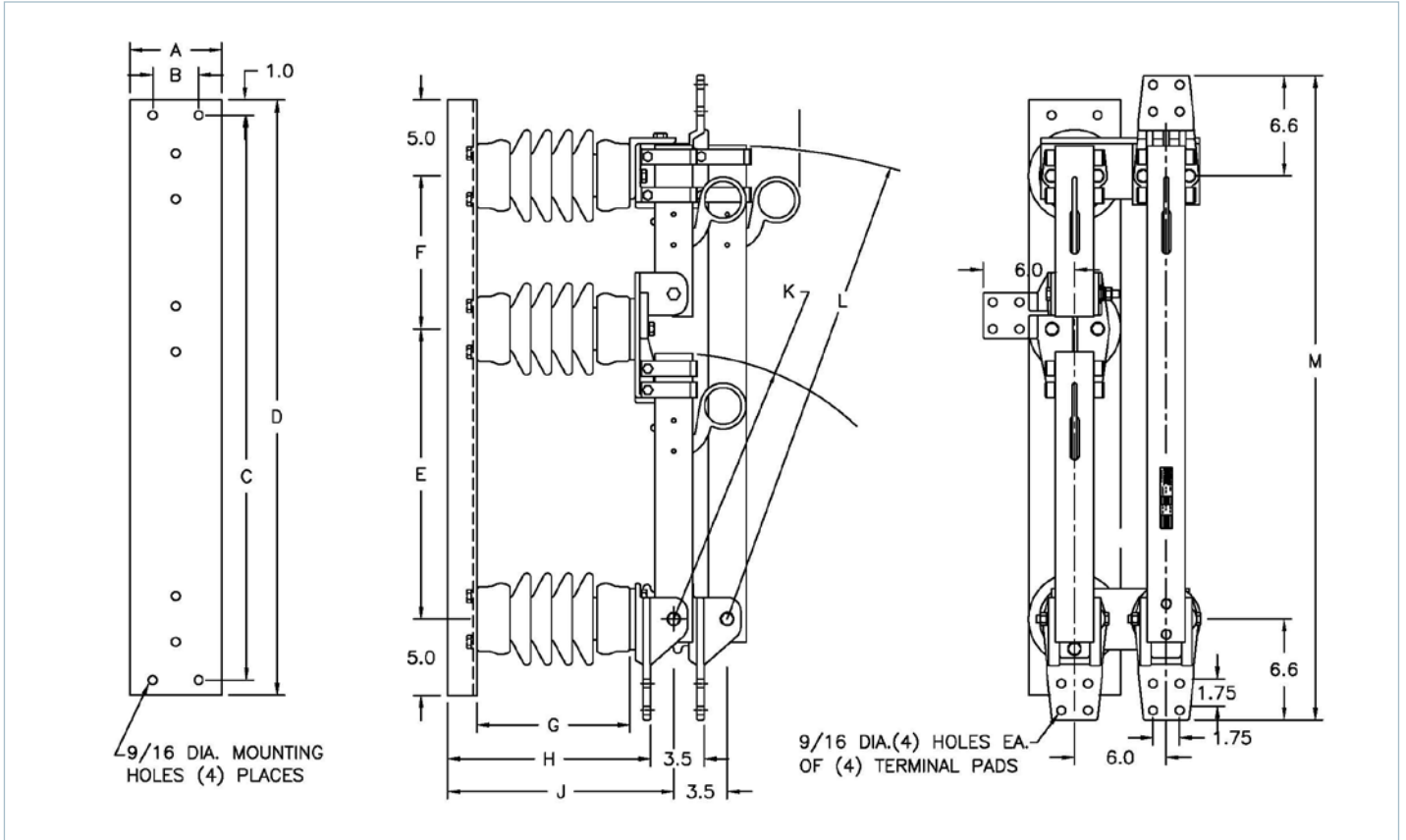

Cat. no.	Rating data				Dimensions - inches													Insulators
	NOM kV	MAX kV	kV BIL	Amps		A	B	C	D	E	F	G	H	J	K	L	M	
625	14.4	15	110	1,200	61,000	6	3	37	39	19	10	10	13.3	14.8	17.4	31	41	3" D.B.C.
725	23	25	150	1,200	61,000	6	3	40	42	22	10	14	17.3	18.8	20.4	34	44	
825	34.5	38	200	1,200	61,000	6	3	46	48	28	10	18	21.3	22.8	26.4	40	50	

Note: Add these suffixes to catalog numbers for the option described

- C = Polymer insulator
- P = Pole mount bracket

QB = Quick break

T = Tinned terminal pads

X = Backplate set

Example: "625CQBT = Type B-1, 15 kV, 110 kV BIL, 1,200 A, polymer insulators, quick break, tinned terminal pads"

Details

Type B-1 regulator bypass: 600 A with Saf-T-Gap interrupter (600 A loadbreak)

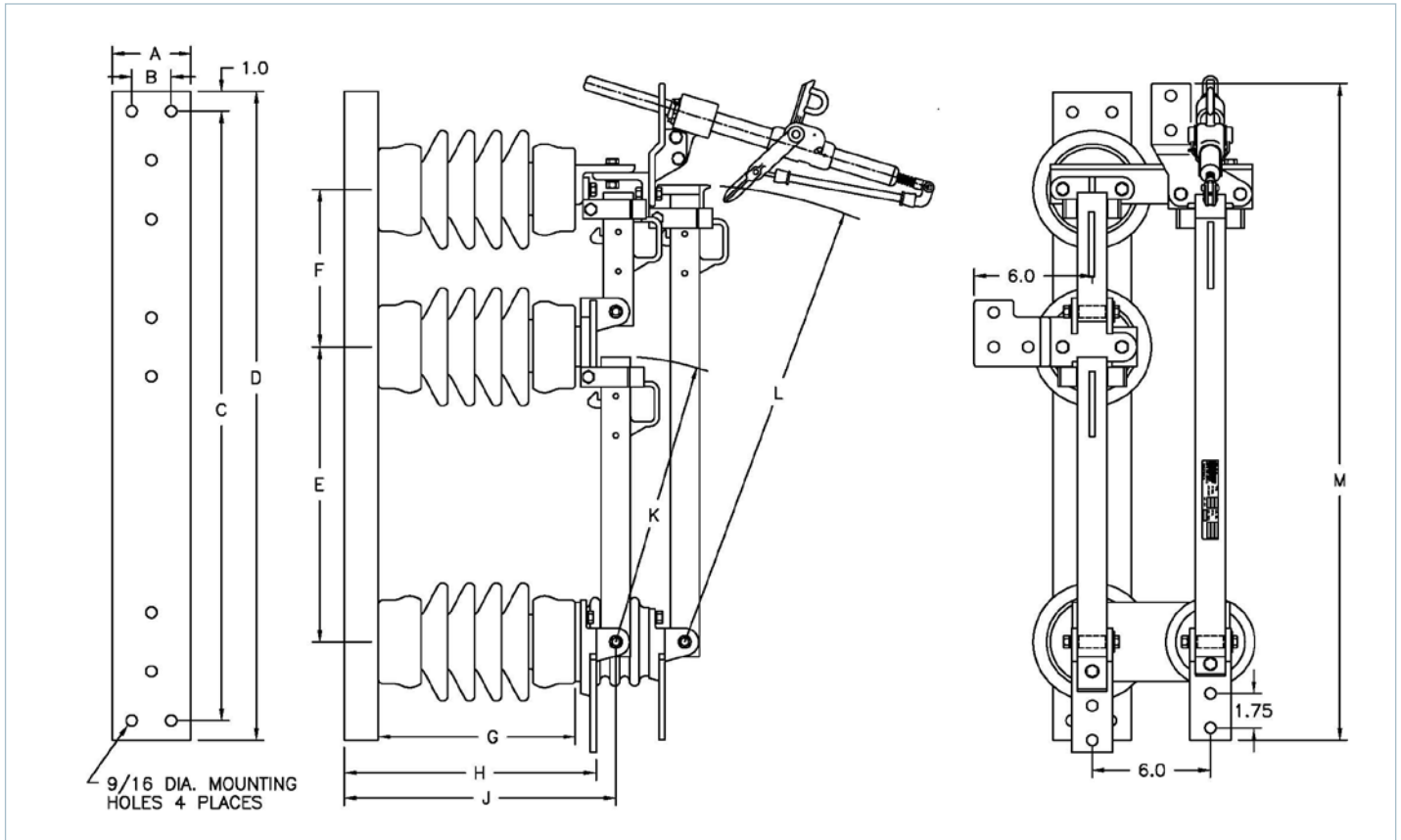

Cat. no.	Rating data			Dimensions - inches														Insulators
	NOM kV	MAX kV	kV BIL	Amps		A	B	C	D	E	F	G	H	J	K	L	M	
				Cont.	Mom.													
675	14.4	15	110	600	40,000	4	2	31	33	15	8	10	13.8	16.3	14.5	23.25	33.4	3" D.B.C.
775	23	25	150	600	40,000	4	2	34	36	18	8	14	16.8	17.5	17.5	26.25	36.4	
875	34.5	38	200	600	40,000	6	3	40	42	24	12	18	20.8	21.3	23.5	32.25	42.4	

Note: Add these suffixes to catalog numbers for the option described

C = Polymer insulator

K = Cable connector

#6 - 397.5 MCM ACSR

#6 - 500 MCM copper

P = Pole mount bracket

T = Tinned terminal pads

X = Backplate set

Example: "675CT = Type B-1, 15 kV, 110 kV BIL, 600 A, polymer insulators, tinned terminal pads"

Details

Type B-1 regulator bypass: 900 A with Saf-T-Gap interrupter (600 A loadbreak)

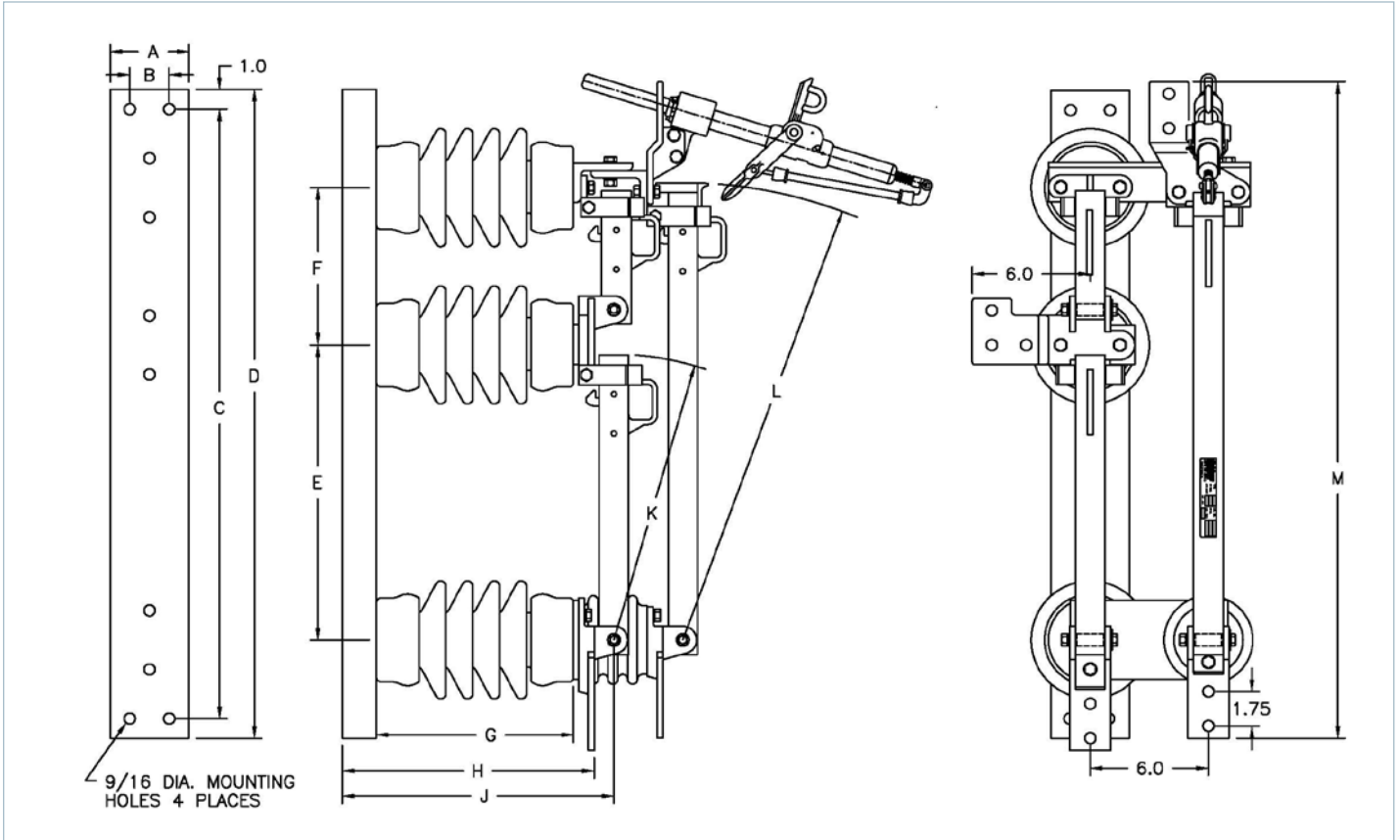

Cat. no.	Rating data			Dimensions - inches															Insulators
	NOM kV	MAX kV	kV BIL	Amps		A	B	C	D	E	F	G	H	J	K	L	M		
695	14.4	15	110	900	40,000	4	2	31	33	15	8	10	13.8	16.3	14.5	23.25	33.4	3" D.B.C.	
795	23	25	150	900	40,000	4	2	34	36	18	8	14	16.8	17.5	17.5	26.25	36.4		
895	34.5	38	200	900	40,000	6	3	40	42	24	12	18	20.8	21.3	23.5	32.25	42.4		

Note: Add these suffixes to catalog numbers for the option described

C = Polymer insulator

K = Cable connector

#6 - 397.5 MCM ACSR

#6 - 500 MCM copper

P = Pole mount bracket

T = Tinned terminal pads

X = Backplate set

Example: "695CT = Type B-1, 15 kV, 110 kV BIL, 900 A, polymer insulators, tinned terminal pads"

Details

Type B-1 regulator bypass: 1,200 A with Saf-T-Gap interrupter (600 A loadbreak)

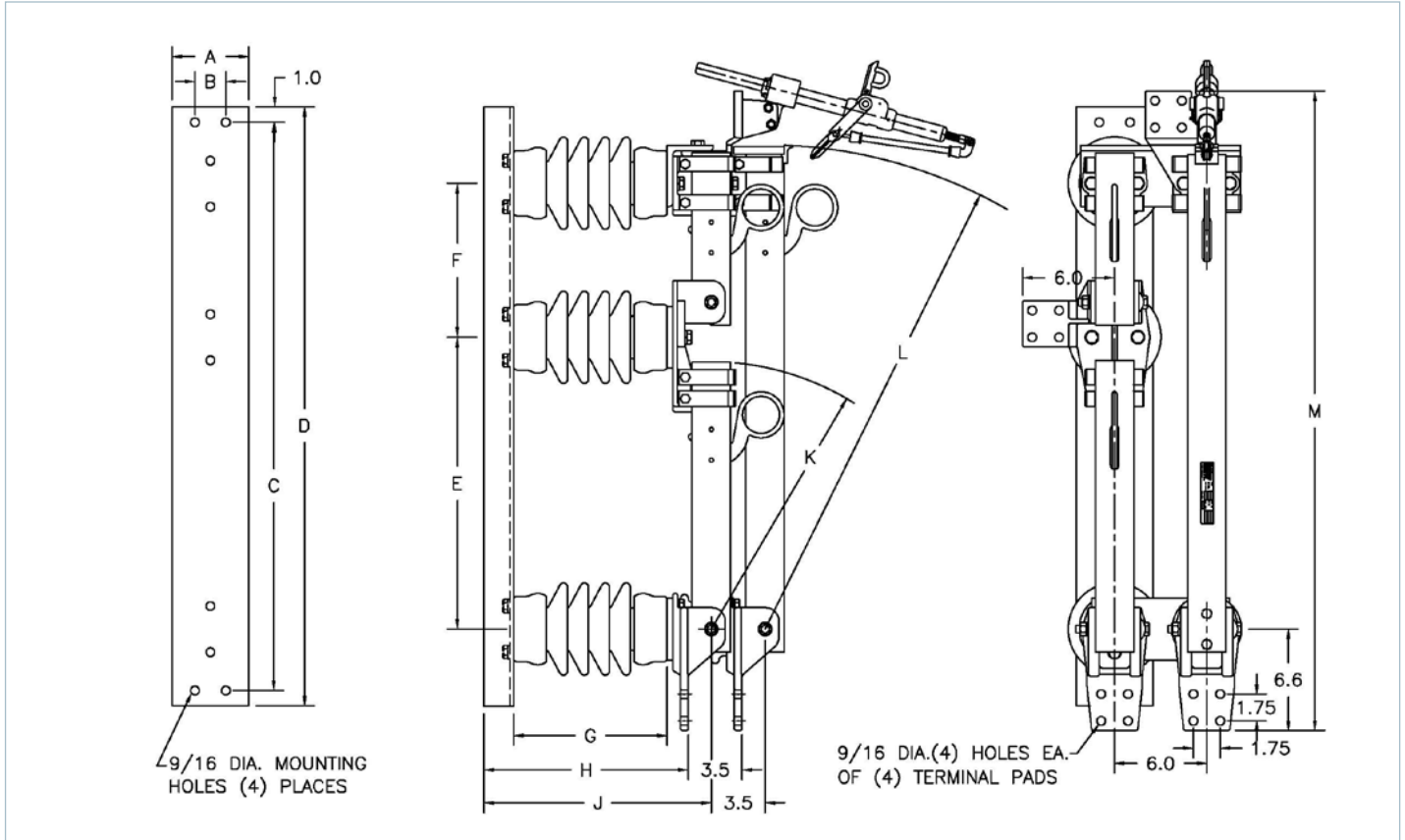

Cat. no.	Rating data			Dimensions - inches														Insulators
	NOM kV	MAX kV	kV BIL	Amps		A	B	C	D	E	F	G	H	J	K	L	M	
685	14.4	15	110	1,200	61,000	5	2	37	39	19	10	10	13.3	14.8	17.4	31.6	41.6	3" D.B.C.
785	23	25	150	1,200	61,000	5	2	40	42	22	10	14	17.3	18.8	20.4	34.6	44.6	
885	34.5	38	200	1,200	61,000	6	3	46	48	28	10	18	21.3	22.8	26.4	40.6	50.6	

Note: Add these suffixes to catalog numbers for the option described

C = Polymer insulator
P = Pole mount bracket

T = Tinned terminal pads

X = Backplate set

Example: "685CT = Type B-1, 15 kV, 110 kV BIL, 1,200 A, polymer insulators, tinned terminal pads"

Options

The Type B-1 regulator bypass disconnects are available with quick break and pole bracket options.

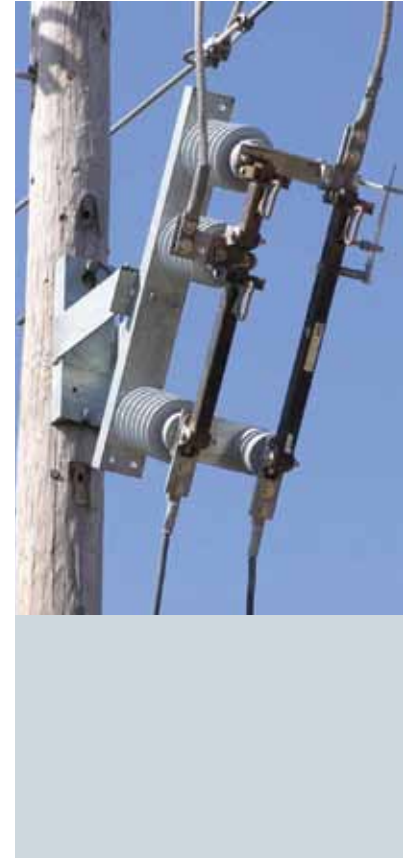
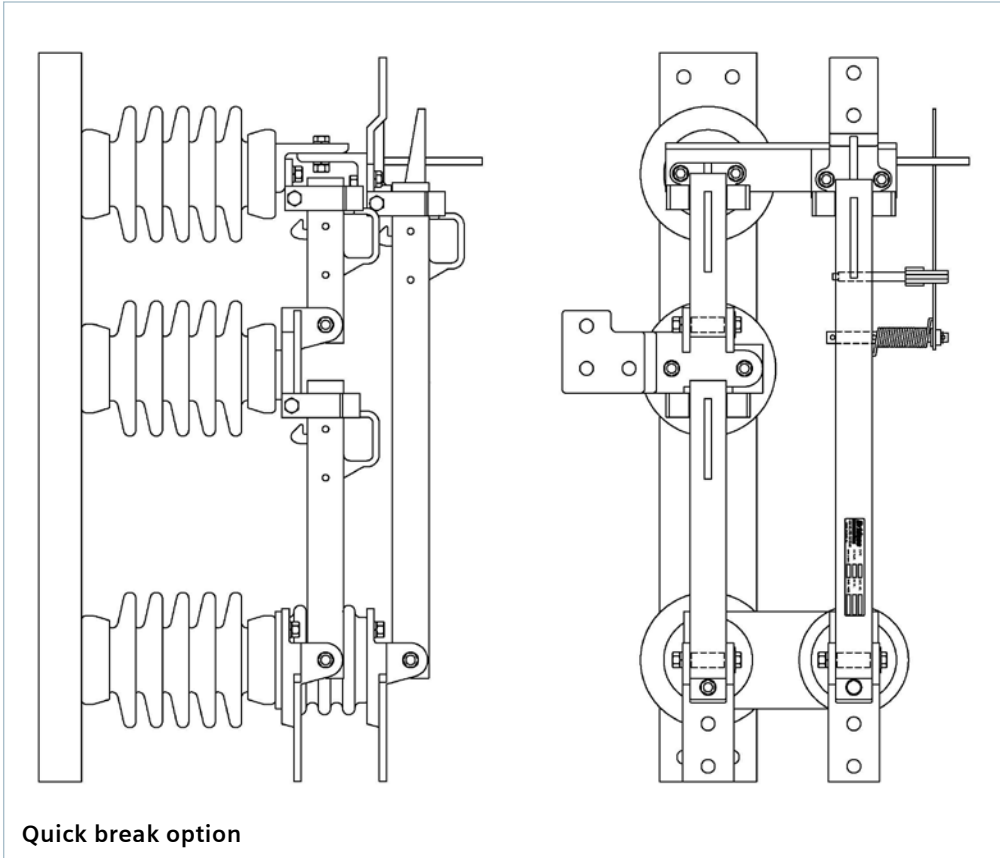

Quick break option

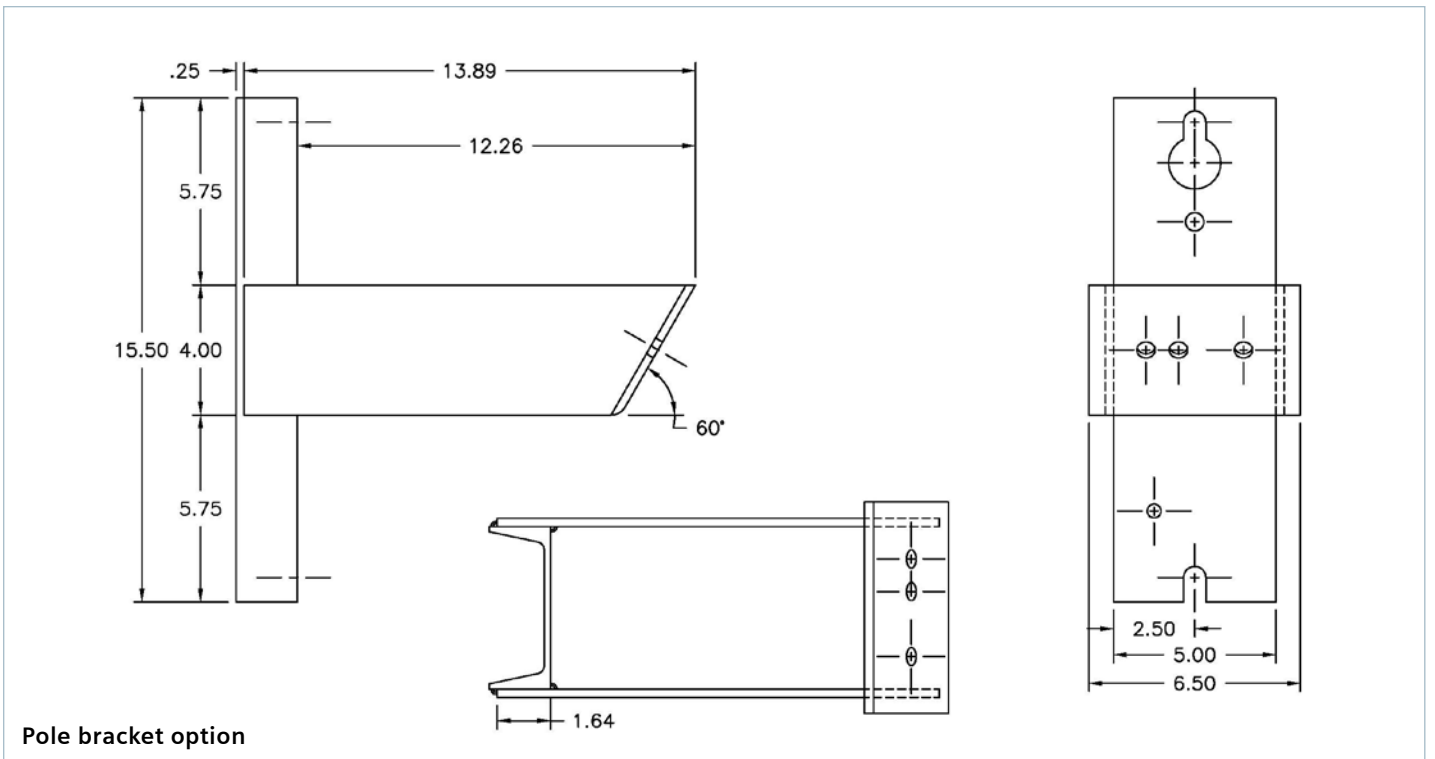

Pole bracket option

Details

Type B-2: O.C.R. (or regulator) bypass 600 A

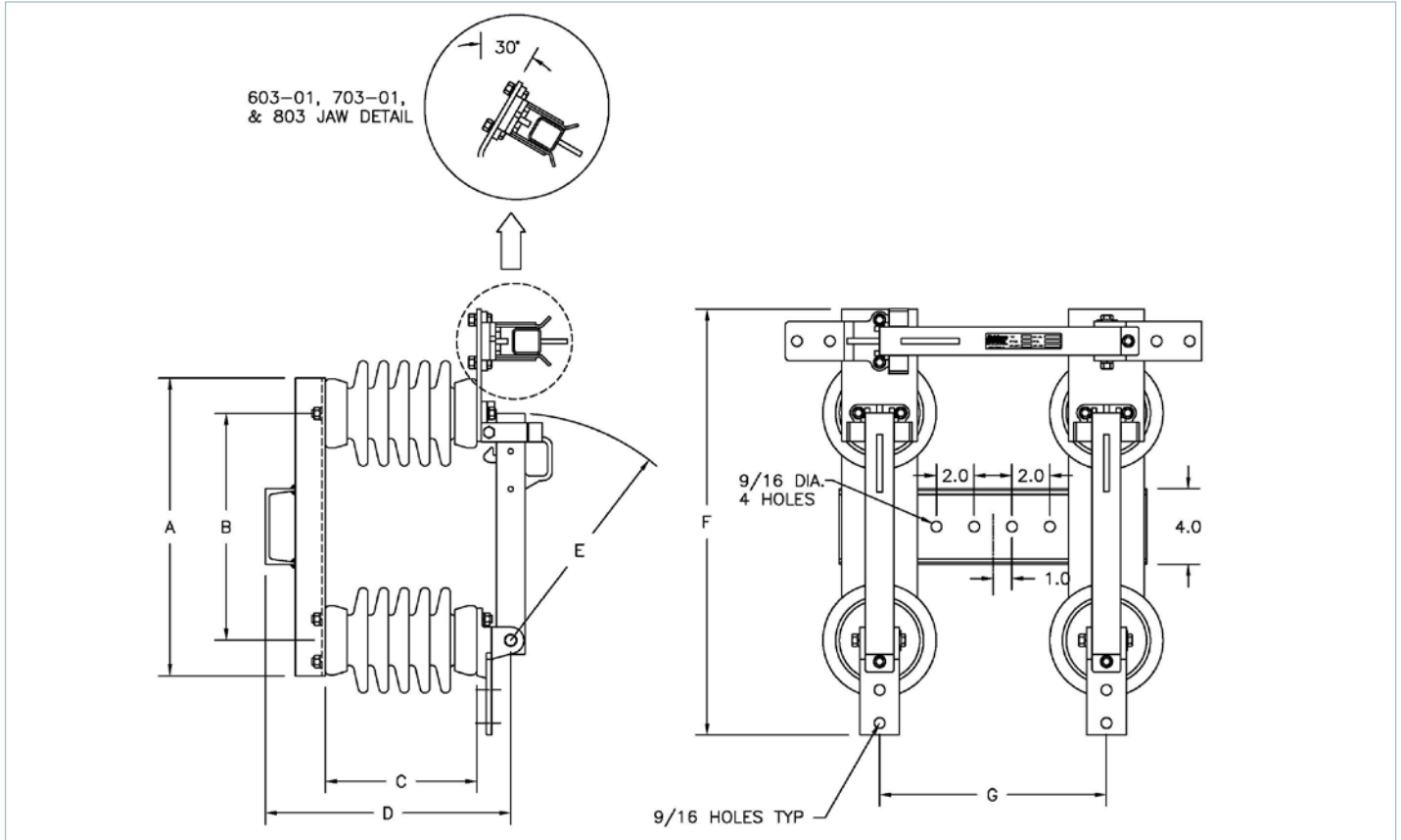

Cat. no.	Rating data					Dimensions - inches						
	NOM kV	MAX kV	kV BIL	Amps		A	B	C	D	E	F	G
				Cont.	Mom.							
603	14.4	15	110	600	40,000	15.8	12	8	12.97	12	22.5	12
703	23	25	150	600	40,000	18.8	15	10	14.97	15	25.5	15
803	34.5	38*	150	600	40,000	21.8	18	10	14.97	18	30	18

* Grounded wye system only

Note: Add these suffixes to catalog numbers for the option described

- C = Polymer insulator
- H = Loadbreak hooks
- K = Cable connector
- #6 - 397.5 MCM ACSR
- #6 - 500 MCM copper
- P = Pole mount bracket

T = Tinned terminal pads

X = Backplate set

L = Bypass blade in "left hand" position

01 = Angled bypass blade

Example: "603-01CPT = Type B-2, 15 kV, 110 kV BIL, 600 A, angled bypass blade, polymer insulators, pole mount bracket, tinned terminal pads"

Details

Type B-2: O.C.R. (or regulator) bypass 900 A

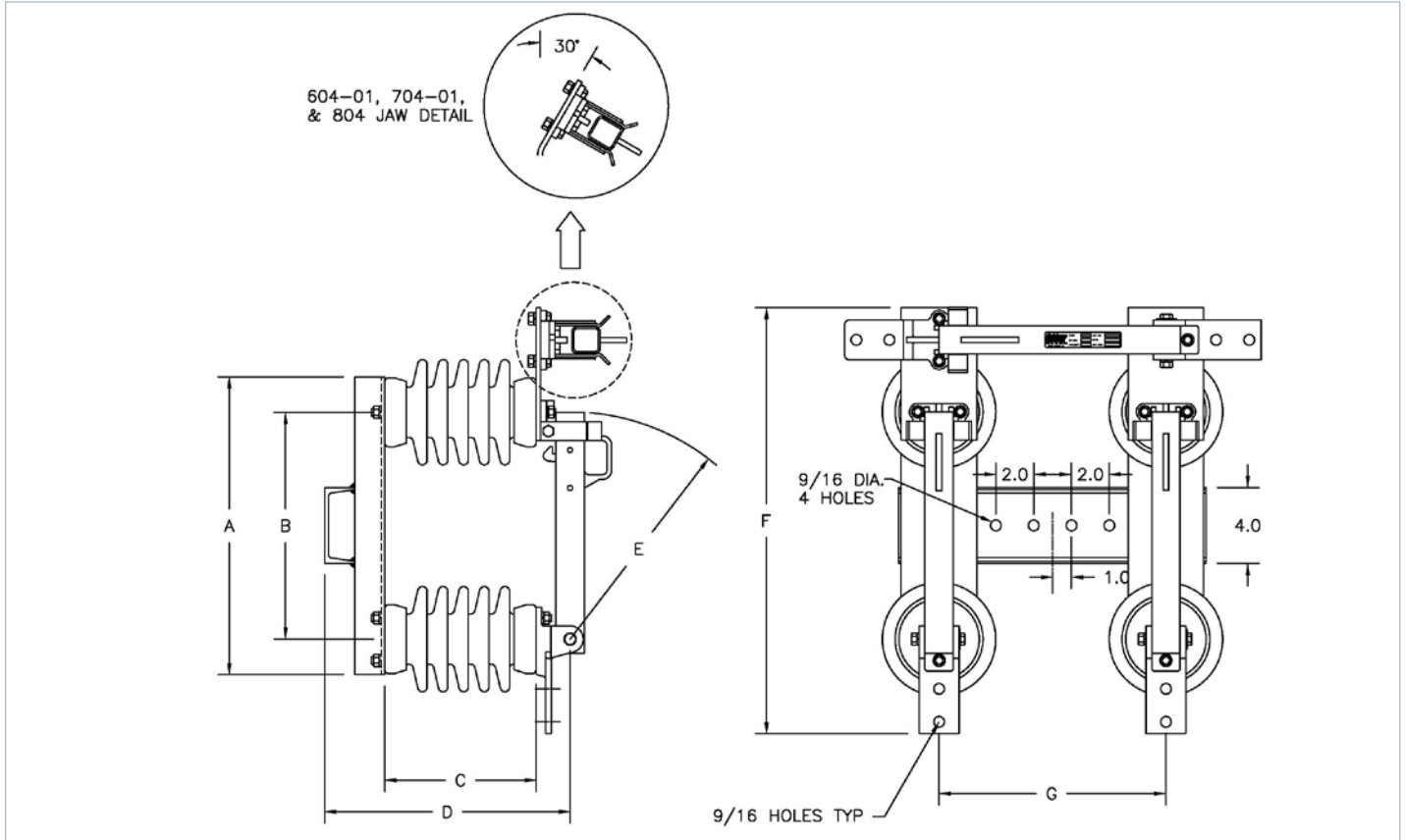

Cat. no.	Rating data					Dimensions - inches						
	NOM kV	MAX kV	kV BIL	Amps		A	B	C	D	E	F	G
				Cont.	Mom.							
604	14.4	15	110	900	40,000	15.8	12	8	12.97	12	22.5	12
704	23	25	150	900	40,000	18.8	15	10	14.97	15	25.5	15
804	34.5	38*	150	900	40,000	21.8	18	10	14.97	18	30	18

* Grounded wye system only

Note: Add these suffixes to catalog numbers for the option described

- C = Polymer insulator
- H = Loadbreak hooks
- K = Cable connector
- #6 - 397.5 MCM ACSR
- #6 - 500 MCM copper
- P = Pole mount bracket

T = Tinned terminal pads

X = Backplate set

L = Bypass blade in "left hand" position

01 = Angled bypass blade

Example: "604-01CPT = Type B-2, 15 kV, 110 kV BIL, 900 A, angled bypass blade, polymer insulators, pole mount bracket, tinned terminal pads"

Details

Type B-2: O.C.R. (or regulator) bypass substation style – 600 A

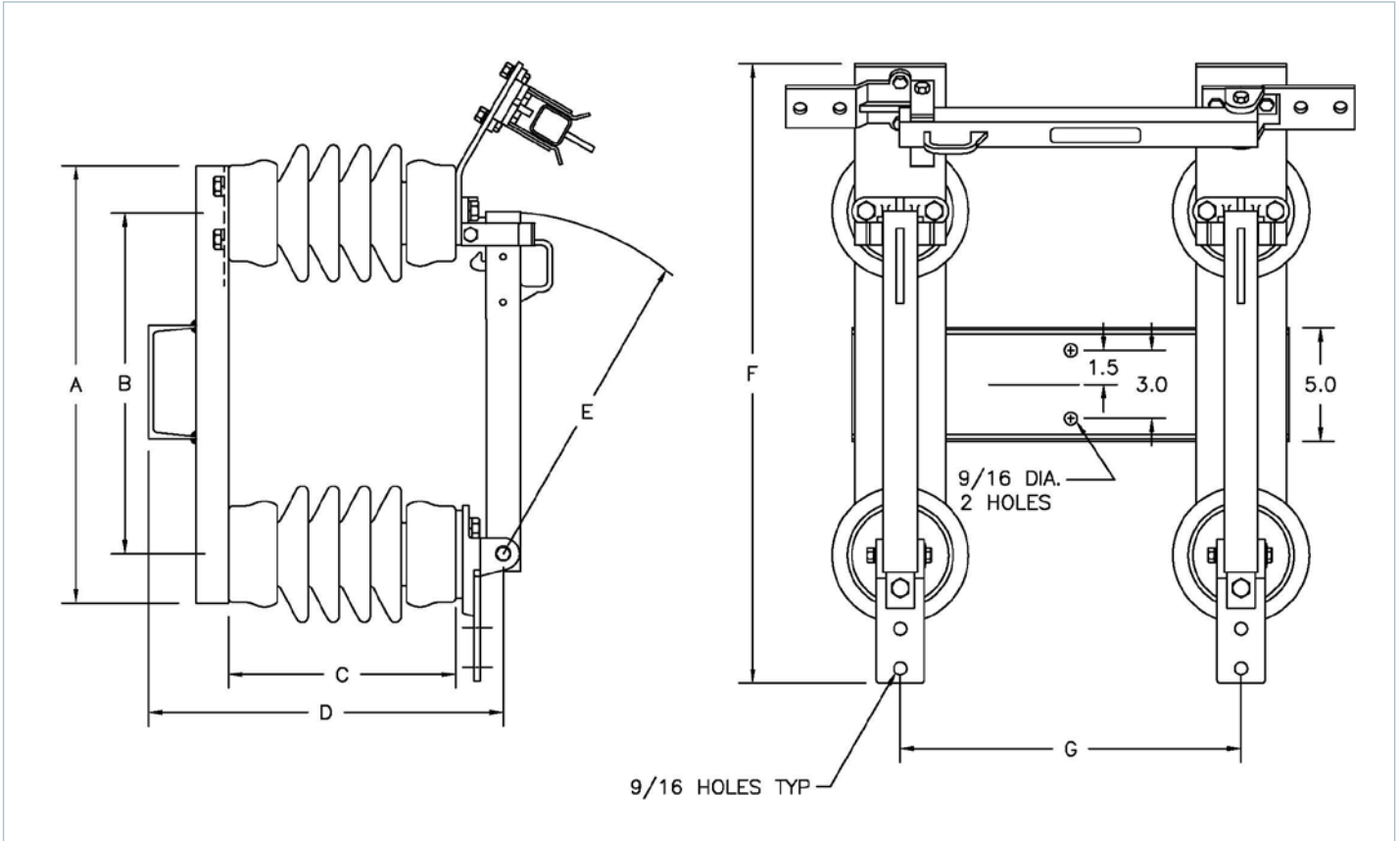

Cat. no.	Rating data					Dimensions - inches						
	NOM kV	MAX kV	kV BIL	Amps		A	B	C	D	E	F	G
				Cont.	Mom.							
605	14.4	15	110	600	40,000	19.3	15	10	15.6	15	27.25	15
705	23	25	150	600	40,000	22.3	18	14	19.6	18	30.25	18
805	34.5	38	200	600	40,000	28.5	24	18	23.6	24	36.25	24

Note: Add these suffixes to catalog numbers for the option described

C = Polymer insulator

H = Loadbreak hooks

K = Cable connector

#6 - 397.5 MCM ACSR

#6 - 500 MCM copper

P = Pole mount bracket

T = Tinned terminal pads

X = Backplate set

L = Bypass blade in "left hand" position

Example: "605CPT = Type B-2, 15 kV, 110 kV BIL, 600 A, polymer insulators, pole mount bracket, tinned terminal pads"

Details

Type B-2: O.C.R. (or regulator) bypass substation style – 900 A

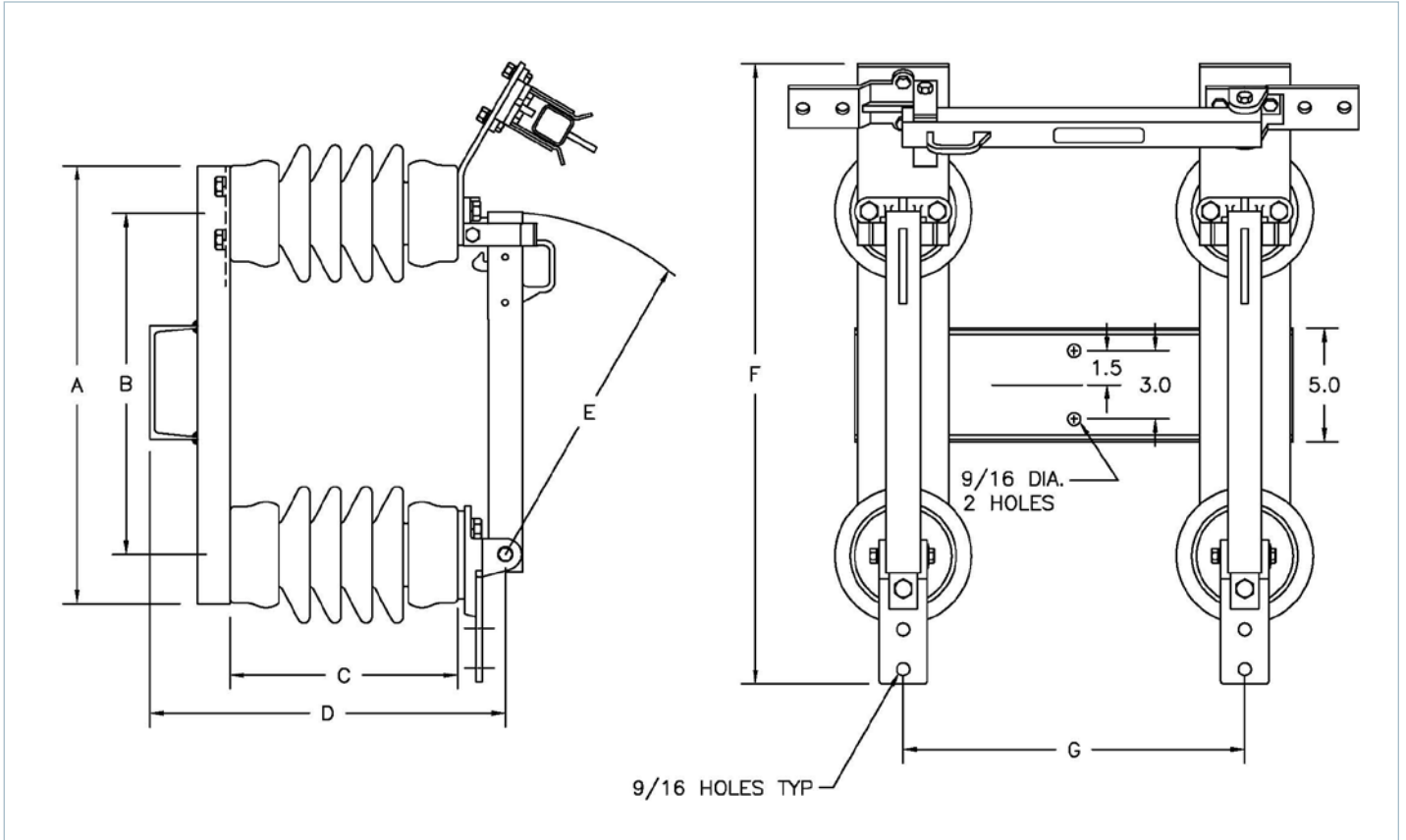

Cat. no.	Rating data					Dimensions - inches						
	NOM kV	MAX kV	kV BIL	Amps		A	B	C	D	E	F	G
				Cont.	Mom.							
606	14.4	15	110	900	40,000	19.3	15	10	15.6	15	27.25	15
706	23	25	150	900	40,000	22.3	18	14	19.6	18	30.25	18
806	34.5	38	200	900	40,000	28.5	24	18	23.6	24	36.25	24

Note: Add these suffixes to catalog numbers for the option described

- C = Polymer insulator
- H = Loadbreak hooks
- K = Cable connector
- #6 - 397.5 MCM ACSR
- #6 - 500 MCM copper
- P = Pole mount bracket

T = Tinned terminal pads

X = Backplate set

L = Bypass blade in "left hand" position

Example: "606CPT = Type B-2, 15 kV, 110 kV BIL, 900 A, polymer insulators, pole mount bracket, tinned terminal pads"

Options

Mounting bracket options

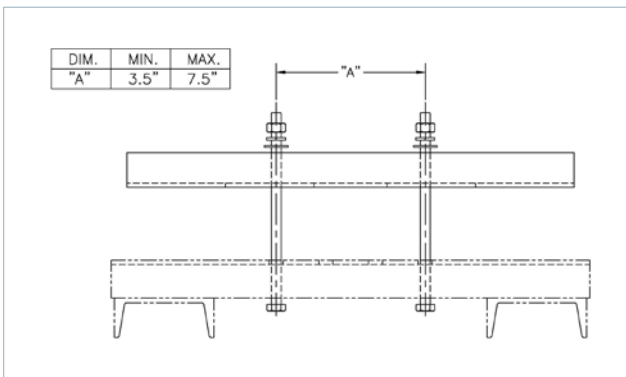
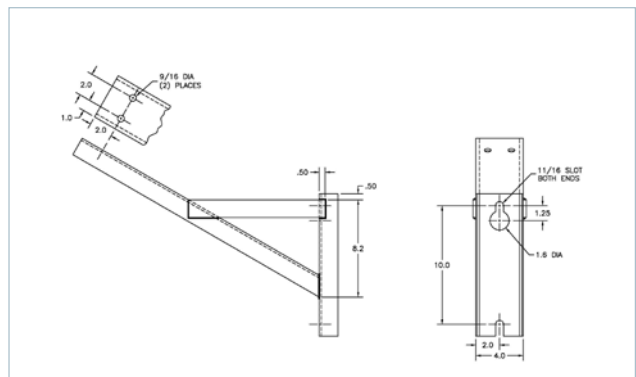
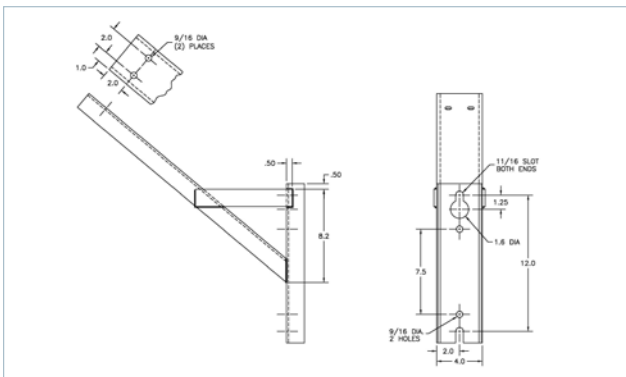
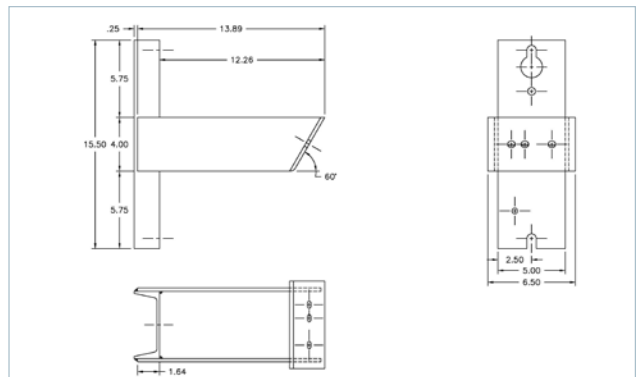
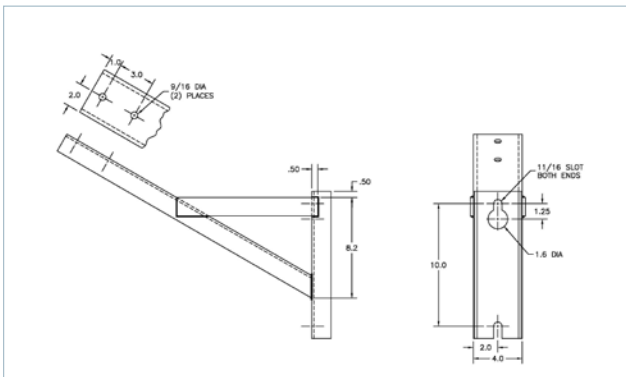
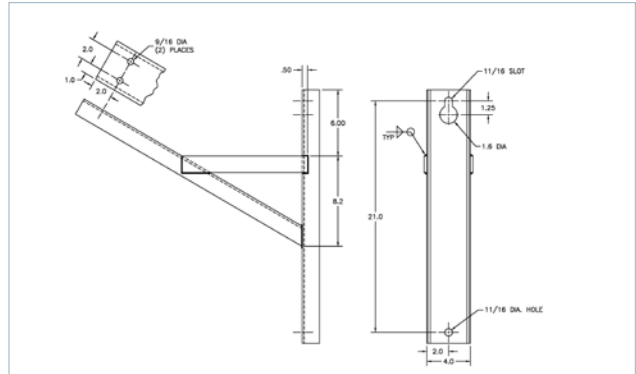
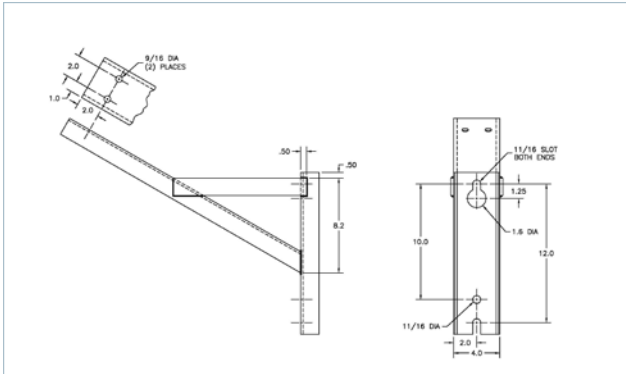

Three-phase recloser bypass assembly



- Three type B-2 recloser bypass switches factory installed on an aluminum or fiberglass arm
- Aluminum or fiberglass arm mounted on adjustable pole gain, which provides the option of angling assembly based upon field conditions
- Single-point lift bracket
- Stable switching action while allowing for a visible indication of a break in the circuit
- Easy identification of the load and source sides in equipment while the circuit is in its normal configuration
- Bypass blades can be easily recognized as open or closed

Contact factory for application information

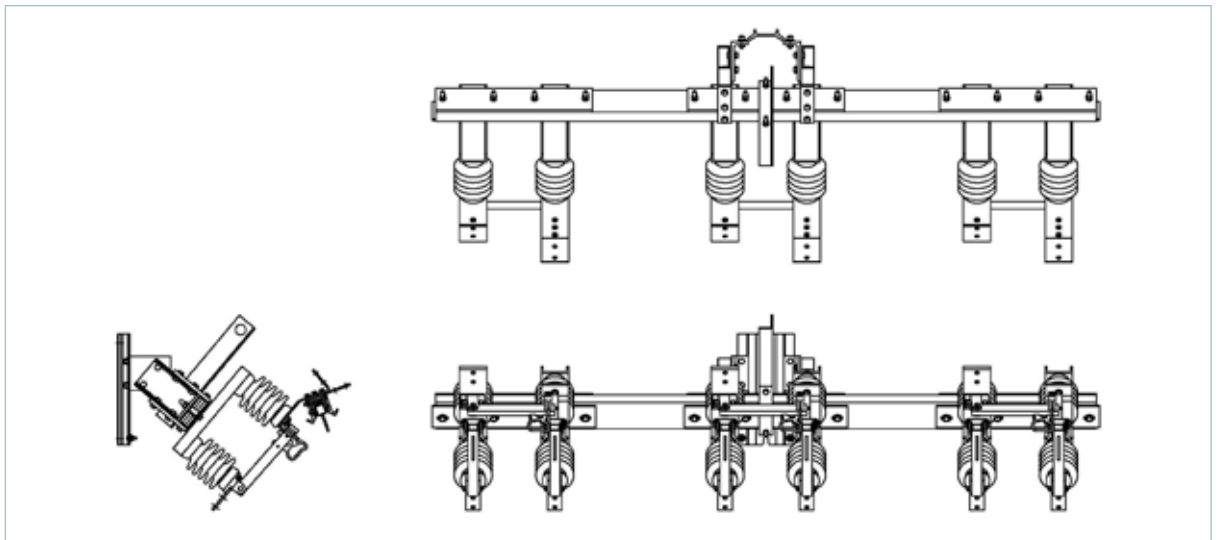

Published by and copyright © 2010:
Siemens AG
Energy Sector
Freyeslebenstrasse 1
91058 Erlangen, Germany

Siemens Energy, Inc.
99 Bolton Sullivan Drive
Heber Springs, AR 72543
Phone: +1 (501) 362-8296
Toll-free: +1 (800) 347-6659

Order No. E50001-F630-A117-X-4A00
Printed in USA
BU 2010115153054664F BR 0710.5

All rights reserved.
Trademarks mentioned in this document
are the property of Siemens AG, its affiliates,
or their respective owners.

Subject to change without prior notice.
The information in this document contains
general descriptions of the technical options
available, which may not apply in all cases.
The required technical options should therefore
be specified in the contract.