

Vector[®]

Group-operated switches manual and motorized

Answers for energy.

SIEMENS

Vector®

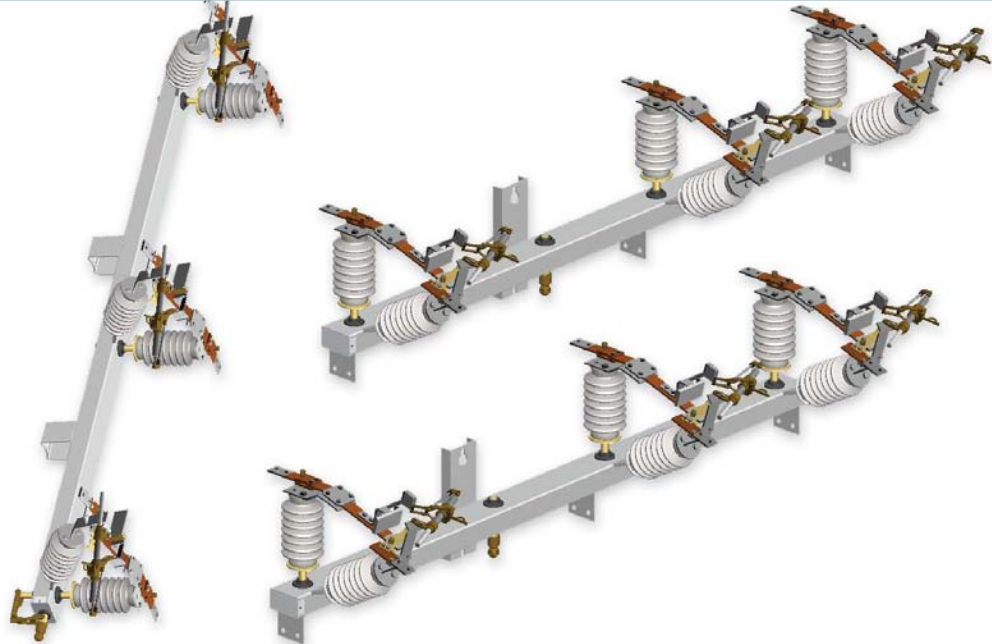

Overview

The Bridges Electric™ Vector® series is a line of group-operated switches designed for superior performance in three-phase loadbreak switching while remaining competitive in price. The Vector is available in ratings of 15/25 kV and 38 kV, 150 kV BIL and 200 kV BIL, 900 A or 1,200 A continuous current and 600 A or 900 A loadbreak. The Vector is manufactured as a true unitized switch; it is not three single-phase switches mounted to a crossarm. The switch is completely factory assembled and adjusted eliminating the need for fine tuning in the field following the installation of the switch. The standard Vector switch incorporates bolt-on interrupters; plug-in interrupters are available as an option.

The unique base assembly consists of a 3" x 5" galvanized steel or 4" x 6" fiberglass tubular housing, oil impregnated sinter bronze bushings, "O" rings with covers and stainless steel end caps (ABS plastic for fiberglass base) that enclose the operating mechanism of the switch for superior weather protection. The internal operating mechanism incorporates an innovative balanced-force concept for ease of operation by balancing the leverage forces on the rotating insulators.

Overview



Installation is made simple with the factory-installed "single-point lift bracket." Provisions for dead-ending all three conductors is standard (on most models) along with the "pole hugger" design for aesthetics. All Vector® series switches are available in pipe-operated versions, hookstick-operated gang (The HOG) versions and motorized versions with SCADA control.

Features

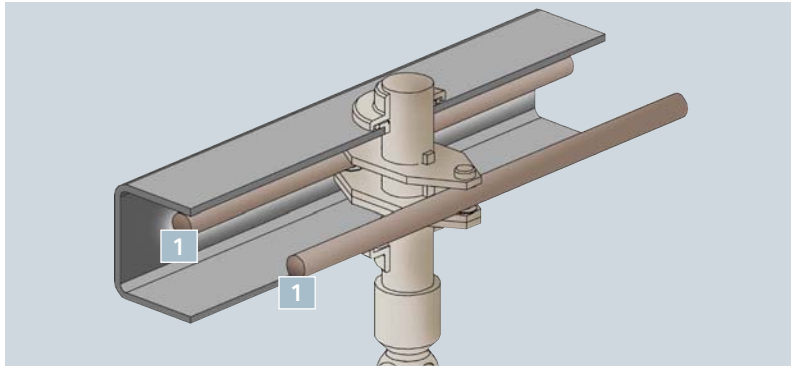

Enclosed operating mechanism

Unique push-pull action of the two interposing rods balances the forces acting on the rotating insulator shafts. The internal operating mechanism gives a very clean and pleasing appearance. It also provides weather protection.

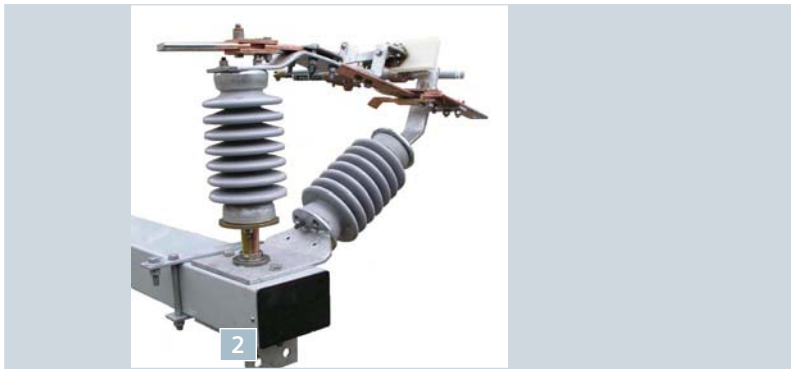

1	Internal operating rods – plated steel on steel base, fiberglass rods on fiberglass base
2	4" x 6" fiberglass switch base
3	Blade, hinge and jaw terminals are 3/8" x 2" bus copper bar; 1/2" x 2" for 1,200 A
4	Contact pressure is preset at the factory by use of a stainless steel spring and mechanical nut
5	Silver washers (two per side) provide an excellent mechanical swivel point, as well as a sound electrical connection
6	Two-hole tinned terminal pads – standard on 900 A; 4-hole pads standard on 1,200 A
7	3" x 5" hot-dipped galvanized steel base

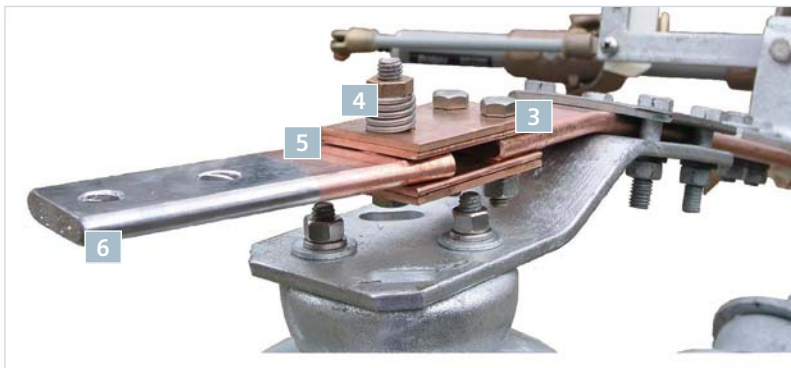

Simple conservative design



Features

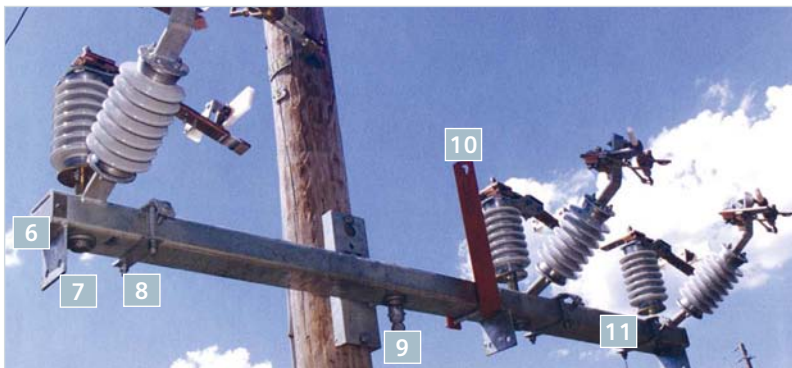
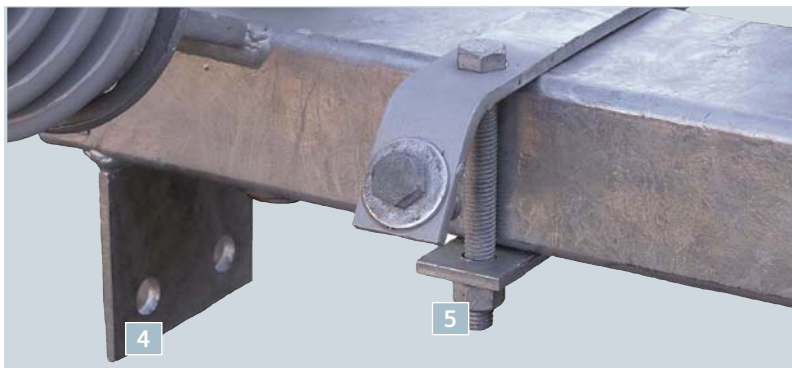
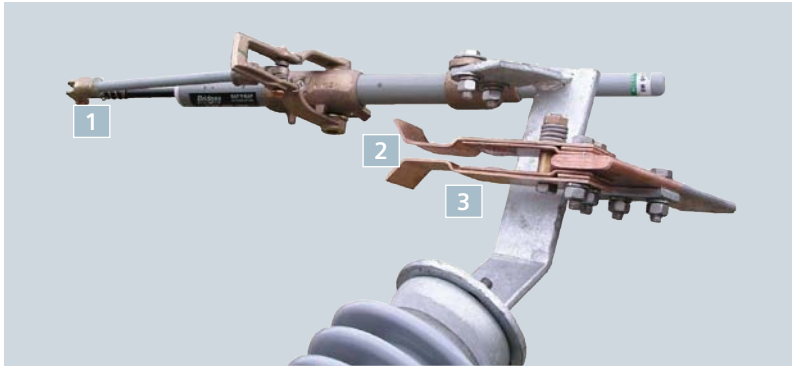

1	Proven Saf-T-Gap interrupter (bolt-on version shown – also available in a plug-in version that is hot stick removable)
2	Separate fault close contacts
3	High-pressure self-cleaning silver contacts
4	Provisions for “dead-ending” (standard on most models)
5	Standard arrester bracket; “A” bracket shown, other designs available
6	Internal operating mechanism is protected inside base
7	Dead-end bracket (standard on most models)
8	Arrester bracket (optional)
9	A “swivel” type connection allows placement of the handle on three faces of the pole – “pole hugger” design
10	Single-point hoist bracket means easy installation – bracket is installed on tested balance point of switch
11	Stiff 3” x 5” galvanized steel base (fiberglass available)
12	Extended arrester bracket – galvanized steel angles or fiberglass angles bolted to dead-end provisions to allow for mounting of arresters farther away from base of switch
13	Fiberglass extended arrester bracket set – option A4
14	Galvanized steel extended arrester bracket set – option A2

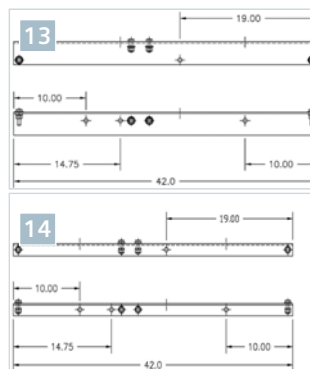

Details

Hookstick-operated gang

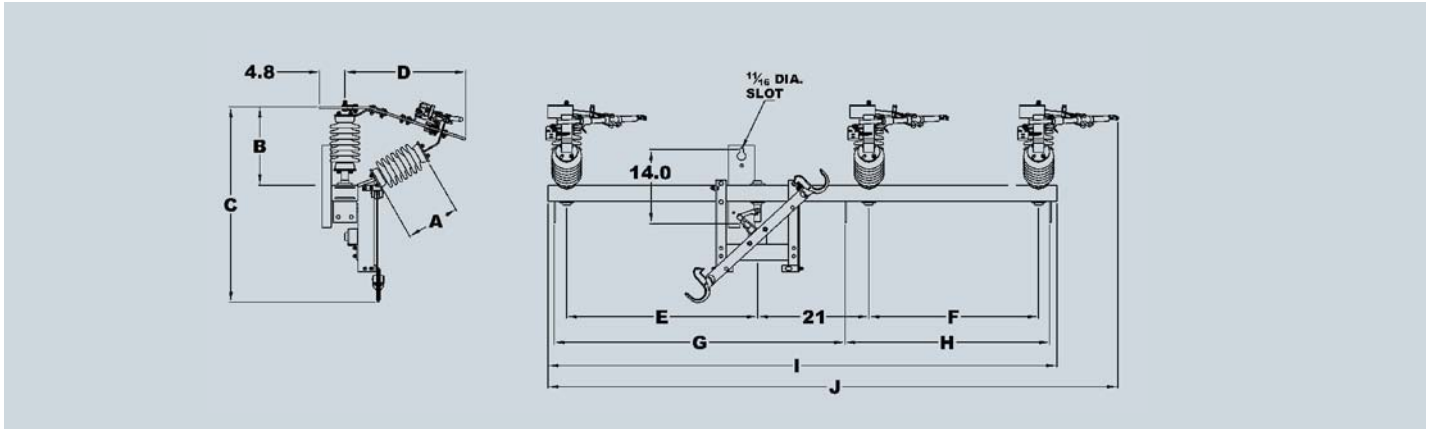

The HOG – horizontal

Cat. no.	Nom kV	kV BIL	Dimensions - inches										Switch weight - pounds*	
			A	B	C	D	E	F	G	H	I	J	Porcelain	Polymer
973X-H	25	150	10	14.8	36.8	22.8	36	32	54.9	38.6	96	107.5	320	275
973XF-H	25	150	10	14.8	36.8	22.8	36	35	60.8	35	101	111.5	320	275
994X-H	38	200	18	22.8	45	28.5	56	48	81.5	48	132	149.3	485	365
994XF-H	38	200	18	22.8	45	28.5	56	48	80.8	48	134	150.3	460	340

* Weight does not include operating pipe.

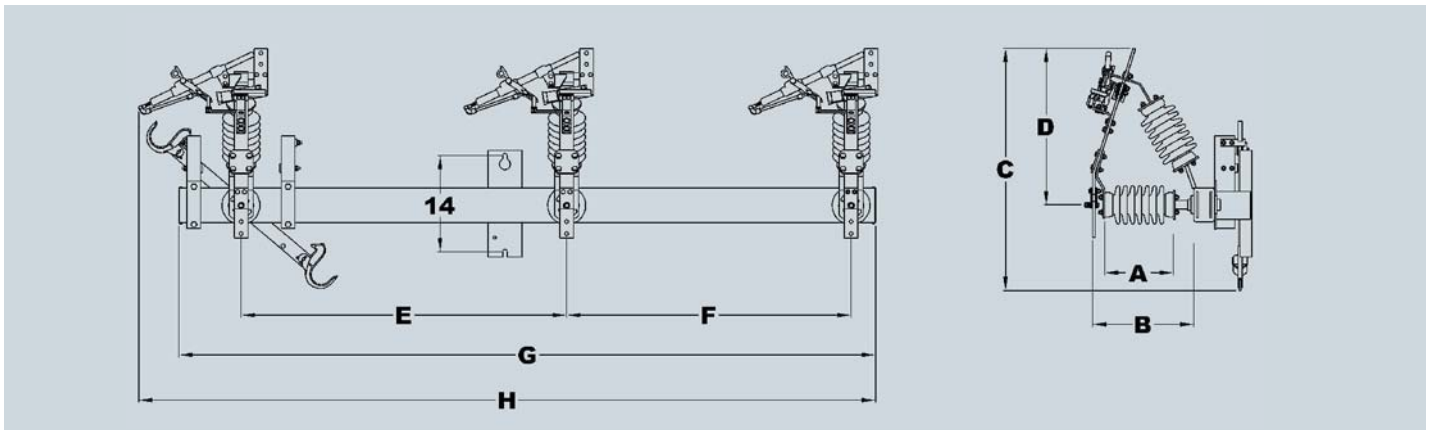

The HOG – vertical

Cat. no.	Nom kV	kV BIL	Dimensions - inches								Switch weight - pounds*	
			A	B	C	D	E	F	G	H	Porcelain	Polymer
973V-H	25	150	10	14.8	35.3	22.8	47.5	41.5	101.5	107.4	335	290
973VF-H	25	150	10	14.8	35.3	22.8	47.5	41.5	102.5	108.4	330	285
994V-H	38	200	18	22.8	41	28.5	48	48	107.5	120.8	470	350
994VF-H	38	200	18	22.8	41	28.5	48	48	109.5	121.8	465	345

* Weight does not include operating pipe.

Details

Pipe operated

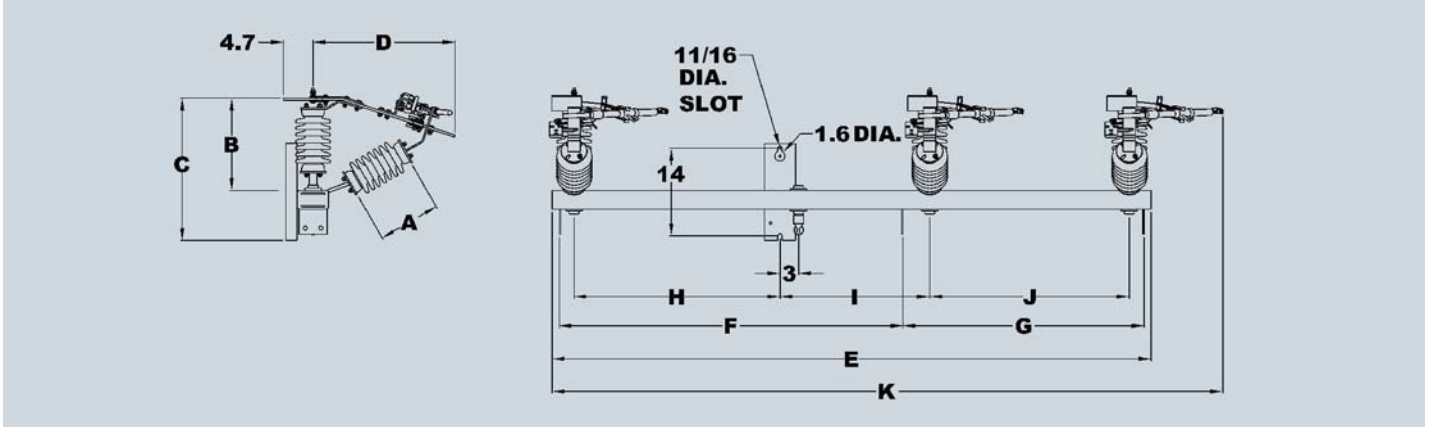

Pipe operated – horizontal

Cat. no.	Nom kV	kV BIL	Dimensions - inches											Switch weight - pounds*	
			A	B	C	D	E	F	G	H	I	J	K	Porcelain	Polymer
973X-30	25	150	10	14.8	22.8	22.8	96	54.9	38.6	33	24	32	107.5	270	225
973XF-30	25	150	10	14.8	24.3	22.8	101	57	38.8	33	24	35	111.5	270	225
994X-30	38	200	18	22.8	30.8	28.5	132	74.9	54.6	53	21	48	149.3	450	330
994XF-30	38	200	18	22.8	32	28.5	134	77	51.7	53	21	48	150.3	445	325

* Weight does not include operating pipe.

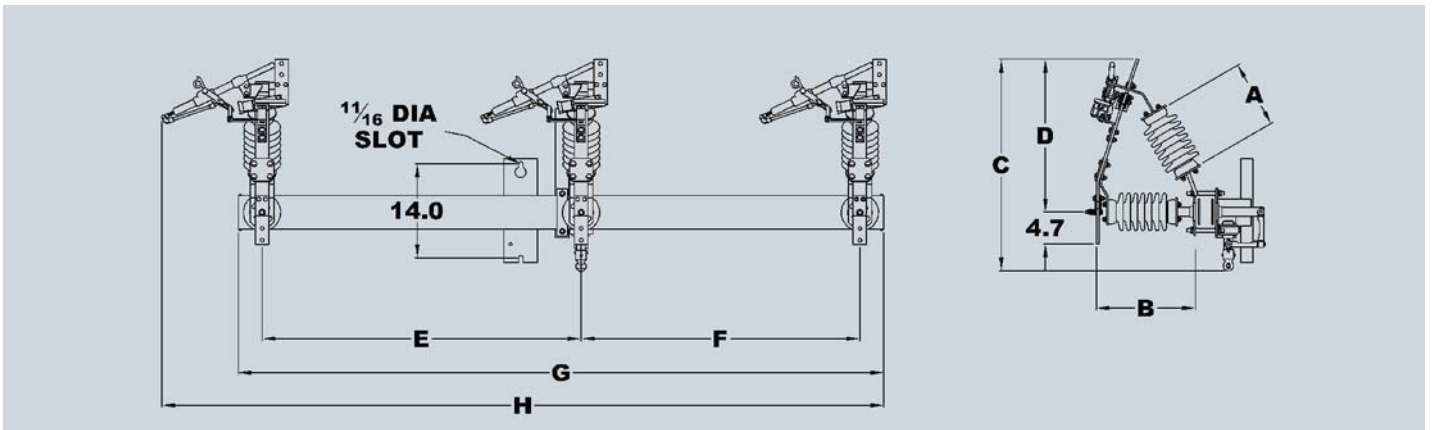

Pipe operated – vertical (cable riser style)

Cat. no.	Nom kV	kV BIL	Dimensions - inches								Switch weight - pounds*	
			A	B	C	D	E	F	G	H	Porcelain	Polymer
973V-30	25	150	10	14.8	31.6	22.8	47.5	41.5	96	107.4	285	245
973VF-30	25	150	10	14.8	31.6	22.8	47.5	41.5	98	108.4	280	240
994V-30	38	200	18	22.8	37.3	28.5	48	48	103	120.8	420	300
994VF-30	38	200	18	22.8	37.3	28.5	48	48	105	121.8	415	295

* Weight does not include operating pipe.

Details

Hookstick-operated gang

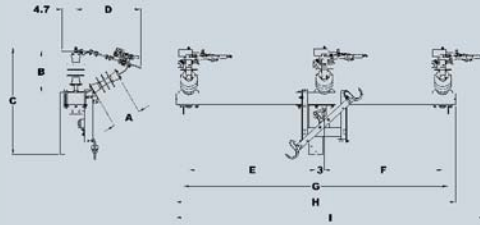

The HOG – symmetrical

Cat. no.	Nom kV	kV BIL	Dimensions - inches									Switch weight - pounds*	
			A	B	C	D	E	F	G	H	I	Porcelain	Polymer
973-H	25	150	10	14.8	36.8	22.8	44.5	32	92.8	96	107.5	335	290
973F-H	25	150	10	14.8	38.4	22.8	44.5	35	92.8	98	108.5	335	290
994-H	38	200	18	22.8	45	28.5	45	48	100.5	103	120.3	470	350
994F-H	38	200	18	22.8	46.1	28.5	45	48	100.5	105	121.3	445	325

* Weight does not include operating pipe.

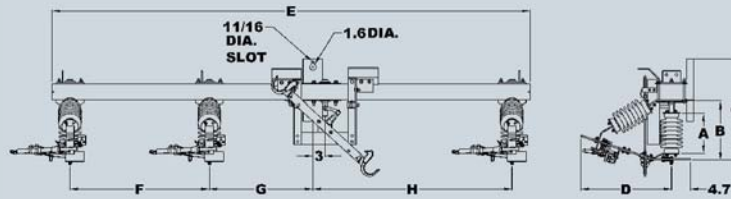

The HOG – inverted

Cat. no.	Nom kV	kV BIL	Dimensions - inches								Switch weight - pounds*	
			A	B	C	D	E	F	G	H	Porcelain	Polymer
973U-H	25	150	10	14.8	24.3	22.8	115	35	26	50	330	290
973UF-H	25	150	10	14.8	25.3	22.8	120	35	26	50	335	295
994U-H	38	200	18	22.8	32	28.5	137	48	29	53	500	380
994UF-H	38	200	18	22.8	33	28.5	139	48	29	53	495	375

* Weight does not include operating pipe.

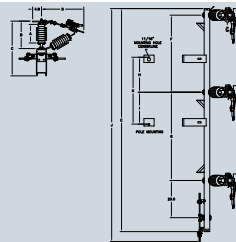

The HOG – phase-over-phase (POP)

Cat. no.	Nom kV	kV BIL	Dimensions - inches											Switch weight - pounds*	
			A	B	C	D	E	F	G	H	I	J	K	Porcelain	Polymer
973P-H	25	150	10	14.8	29.5	22.8	120	41.5	47.5	18.9	17.1	125.4	36	335	290
973PF-H	25	150	10	14.8	30.7	22.8	105	36	36	18	18	109.3	36	300	255
994P-H	38	200	18	22.8	37.5	28.5	127.1	48	48	36	36	132.4	72	465	345
994PF-H	38	200	18	22.8	38.7	28.5	129	48	48	36	36	133.4	72	440	320

* Weight does not include operating pipe.

Details

Pipe operated

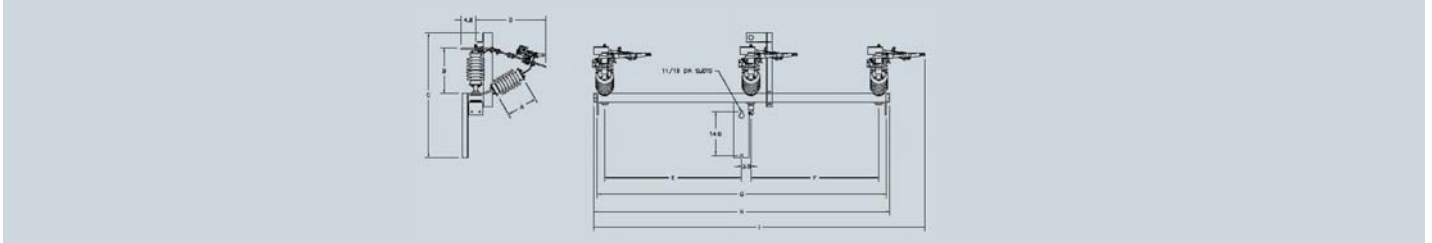

Pipe operated – symmetrical

Cat. no.	Nom kV	kV BIL	Dimensions - inches									Switch weight - pounds*	
			A	B	C	D	E	F	G	H	I	Porcelain	Polymer
973-30	25	150	10	14.8	35.5	22.8	44.5	41.5	93.5	96	107.5	285	245
973F-30	25	150	10	14.8	36.5	22.8	44.5	41.5	92.8	98	108.5	280	240
994-30	38	200	18	22.8	43.5	28.5	45	48	100.5	103	120.3	420	300
994F-30	38	200	18	22.8	44.2	28.5	45	48	99.8	105.1	121.3	415	295

* Weight does not include operating pipe.

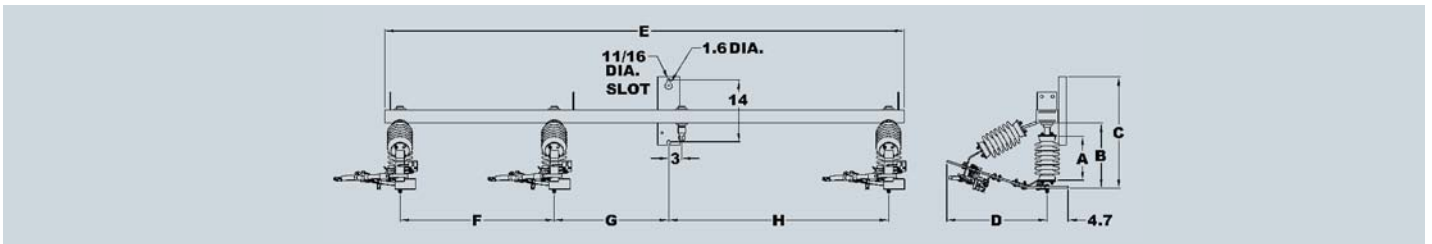

Pipe operated – inverted

Cat. no.	Nom kV	kV BIL	Dimensions - inches									Switch weight - pounds*	
			A	B	C	D	E	F	G	H	Porcelain	Polymer	
973U-30	25	150	10	14.8	25.3	22.8	118	35	26	50	280	240	
973UF-30	25	150	10	14.8	25.3	22.8	120	35	26	50	285	245	
994U-30	38	200	18	22.8	33	28.5	132	48	24	53	450	330	
994UF-30	38	200	18	22.8	33	28.5	134	48	24	53	445	325	

* Weight does not include operating pipe.

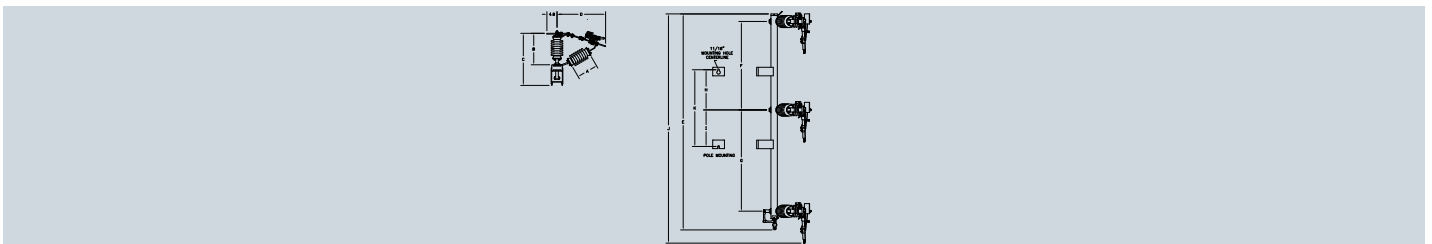

Pipe operated – phase-over-phase (POP)

Cat. no.	Nom kV	kV BIL	Dimensions - inches											Switch weight - pounds*	
			A	B	C	D	E	F	G	H	I	J	K	Porcelain	Polymer
973P-30	25	150	10	14.8	24.5	22.8	101.3	41.5	47.5	18.9	17.1	107.5	36	285	245
973PF-30	25	150	10	14.8	30.7	22.8	85.3	36	36	18	18	91.5	36	280	240
994P-30	38	200	18	22.8	32.5	28.5	103	48	48	36	36	103	72	400	280
994PF-30	38	200	18	22.8	38.7	28.5	109.3	48	48	36	36	121.3	72	390	270

* Weight does not include operating pipe.

Configurations

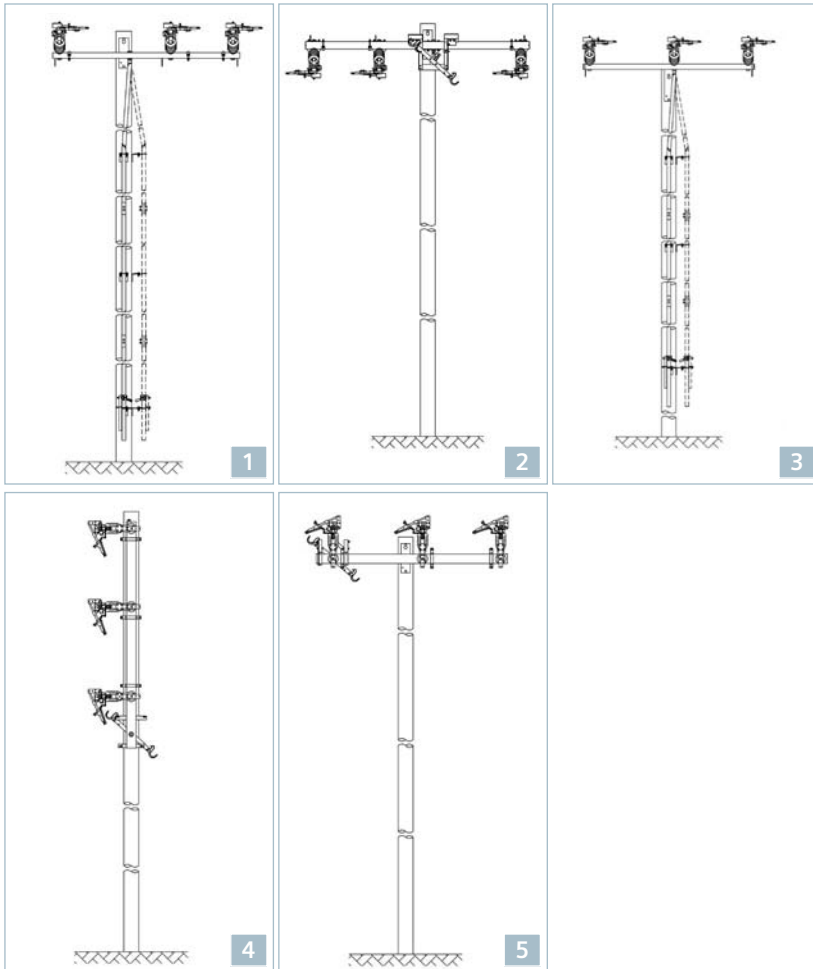

The Vector® series is available in pipe-operated and hookstick-operated (The HOG) versions. For additional options or configurations, please contact your Siemens representative.

1	Horizontal Vector pipe-operated
2	Inverted Vector hookstick-operated - The HOG
3	Symmetrical Vector (pole-top style) pipe-operated
4	Phase-over-phase Vector hookstick-operated - The HOG
5	Vertical Vector (cable riser style) hookstick-operated - The HOG



Automation

The Bridges Electric™ line of switches is very versatile when it comes to operating a motorized switch locally or remotely. The Auto Vector (AV), AutoPack Vector (APV), Auto-Throwover (ATO) and Auto-Sectionalizer are all reliable means of motorized switching and are each tailored to meet the specific needs of electric utilities. We can offer voltage sensors mounted directly to the switch unit for three-phase voltage monitoring, as well as the Bridges Electric RCMS (remote current monitoring system), which is a cost effective alternative for current monitoring and fault detection. The Bridges Electric line of switches has provided reliable solutions to electric utilities for their distribution automation needs for many years.

Vector® numbering system



900 A continuous current	9
1,200 A continuous current	19

2 1/4" D.B.C. polymer insulators	6
2 1/4" D.B.C. porcelain insulators	7
3" D.B.C. polymer insulators	8
3" D.B.C. porcelain insulators	9

25 kV; 150 kV BIL	3
38 kV; 200 kV BIL	4

No letter indicates symmetrical pole-top style	
Horizontal crossarm style	X
Phase-over-phase style	P
Vertical (cable riser style)	V
Underslung (inverted style)	U

No letter indicates galvanized steel switch base	
Fiberglass switch base	F

28' of operating pipe (4@7')	3
35' of operating pipe (5@7')	4
49' of operating pipe (7@7')	5

No operating shaft insulator	0
Porcelain operating shaft insulator	1
Polymer operating shaft insulator	5

Lightning arrester mounting bracket (GALV)	A
Extended lightning arrester mounting bracket (GALV)	A2
Extended lightning arrester mounting bracket (F/G)	A4
Pole band	B
Convertible to motorized	C
Dead-end provisions (standard on some models)	D
Extended base length	E
Fiberglass operating pipe section	F
Hookstick operated - The HOG	H
Six (6) cable connectors	K
Three (3) 16" extension links	L
Marine grade	M
Non-load break	N
Cross arm brace	R
Plug-in Saf-T-Gap interrupters – 900 A	S
Bolt-on Saf-T-Gap interrupters – 900 A	T
Wildlife design	W

Vector ratings:

- 900 A continuous current
- 600/630 A loadbreak
- 40,000 A momentary current loadbreak
- 25,000 A 3-second
- 20,000 A (1-time) symmetrical fault close in
- 15,000 A (3-ime) symmetrical fault close in.

Standard features:

- Silver-to-silver hinge and jaw contacts
- Provisions for dead-ending on switch (optional on phase-over-phase)
- Enclosed balanced bearing operating mechanism
- Pole hugger operating shaft for improved installation appearance
- Four 7-ft. pipe sections, handle and locking assembly and necessary couplings and guides
- Single-point hoist bracket - remove after installation (permanent installation on phase-over-phase)
- All components packaged in one crate
- Bolt-on Saf-T-Gap interrupters
- Copper-bronze hot parts
- Tinned terminal pads.

Published by and copyright © 2010:
Siemens AG
Energy Sector
Freyeslebenstrasse 1
91058 Erlangen, Germany

Siemens Energy, Inc.
99 Bolton Sullivan Drive
Heber Springs, AR 72543
Phone: +1 (501) 362-8296

Order No. E50001-F630-A167-X-76US
Printed in USA
TB 1235T BR 1010.5

All rights reserved.
Trademarks mentioned in this document
are the property of Siemens AG, its affiliates,
or their respective owners.

Subject to change without prior notice.
The information in this document contains
general descriptions of the technical options
available, which may not apply in all cases.
The required technical options should therefore
be specified in the contract.